

DENALI™

HMT.04.10000

COMPACT HORN MOUNT

KTM 1190 ADVENTURE
2014 -

KTM 1290 ADVENTURE
2015 -

Thank you for choosing DENALI

We know you would rather be riding your bike than wrenching on it, so we go the extra mile to make sure our instructions are clear and as easy to understand as possible. If you have any questions, comments, or suggestions don't hesitate to give our gear experts a call at 855.255.5550 or visit DenaliElectronics.com/instructions.

Please Read Before Installing

DENALI products should always be installed by a qualified motorcycle technician. If you are unsure of your ability to properly install a product, please have the product installed by your local motorcycle dealer. DENALI takes no responsibility for damages caused by improper installation. **Caution:** When installing electronics it is extremely important to pay close attention to how wires are routed, especially when mounting products to the front fender, front forks, or fairing of your motorcycle. Always be sure to turn the handlebars fully left, fully right, and fully compress the suspension to ensure the wires will not bind and have enough slack for your motorcycle to operate properly.

Installation Tips

We strongly recommend using medium strength liquid thread locker on all screws, nuts, and bolts. It is also important to ensure that all hardware is tightened to the proper torque specifications as listed in your owner's manual. For included accessory hardware please refer to the default torque specifications provided below. Inspect all hardware after the first 30 miles to ensure proper torque specifications are maintained.

Bolt Size	in-lbs	ft-lbs	Nm
M3	10.0 in-lbs	-	1.0 Nm
M4	23.0 in-lbs	-	2.5 Nm
M5	44.5 in-lbs	3.5 ft-lbs	5.0 Nm
M6	78.0 in-lbs	6.5 ft-lbs	9.0 Nm
M8	-	13.5 ft-lbs	18.0 Nm
M10	-	30.0 ft-lbs	41.0 Nm
M12	-	52.0 ft-lbs	71.0 Nm

Hardware Sizing Guide

Not sure what size bolt you have? Use this metric ruler to measure screws, bolts, spacers, etc. Remember, the length of a screw or bolt is measured from the start of the "mounting surface" to the end of the screw, so only include the screw head when measuring countersunk screws.

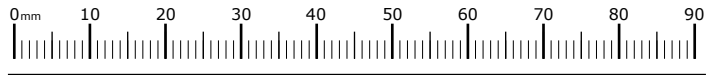

FIGURE 1

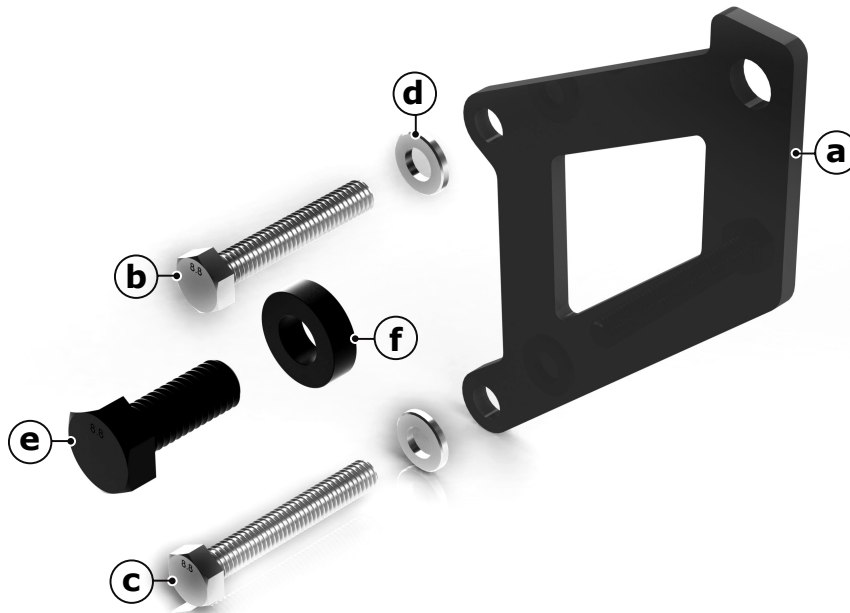

Illustration not to scale

Kit Contents

- (a) Bracket (HMT.04.001).....Qty 1
- (b) M6x40 DIN 933.....Qty 1
- (c) M6x35 DIN 933.....Qty 1
- (d) M6 Washer DIN 125.....Qty 2
- (e) M8x20 DIN 933.....Qty 1
- (f) OD:16mm ID:8mm L: 5mm...Qty 1

Tools Required

- 13mm Wrench
- 10mm Wrench
- T30 Torx Driver

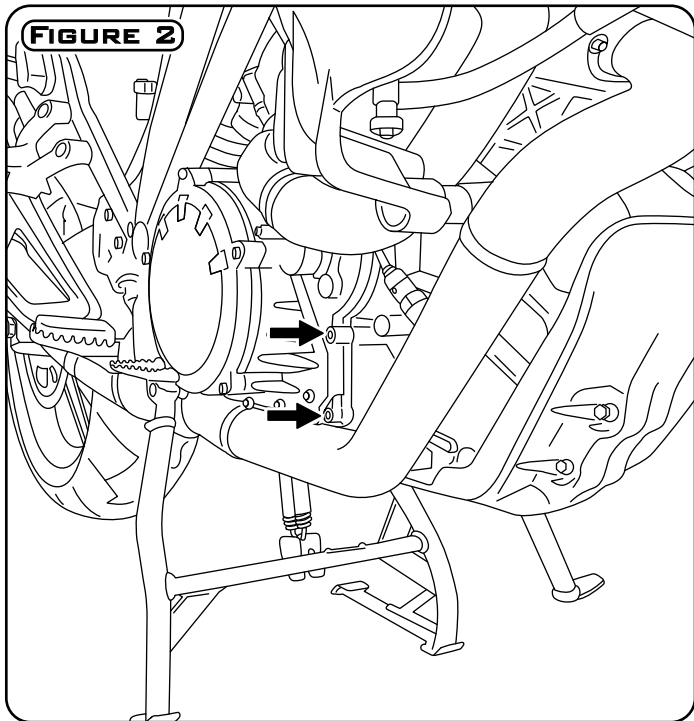

Removing The OEM Bolts

Step One: Identify and remove the two OEM M6 bolts. They are located on the right hand side of the motorcycle, just in front of the clutch case .

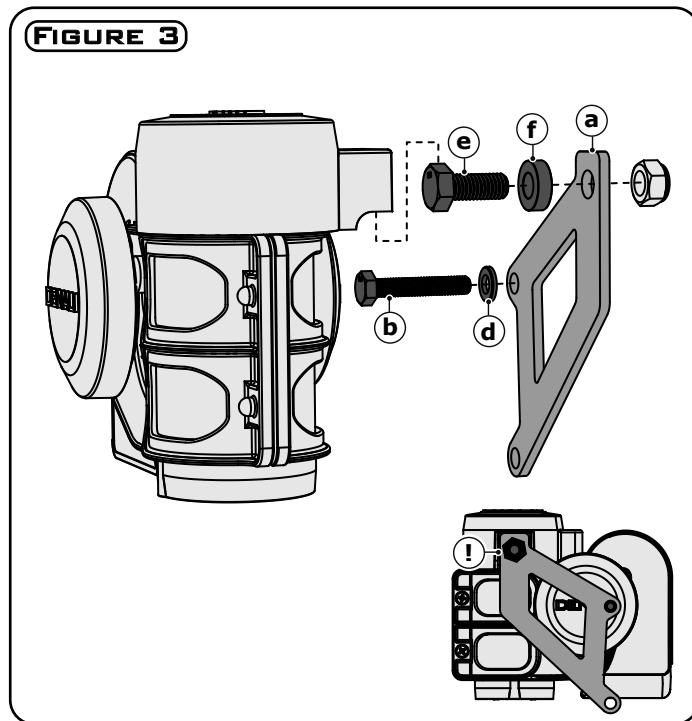

Mounting The Horn To The Bracket

Step Two: Before mounting the horn to the bracket, insert the M6x40 bolt (b) through a M6 washer (d) and the upper 6mm hole of bracket (a).

Step Three: Use the M8x20 bolt (e), spacer (f) and the nut supplied with the SoundBomb Compact Horn to bolt the horn to the bracket (a). Torque to 13.5 ft-lbs.

! Note: The horn is to be bolted so that its parallel to the front edge of bracket (a.)

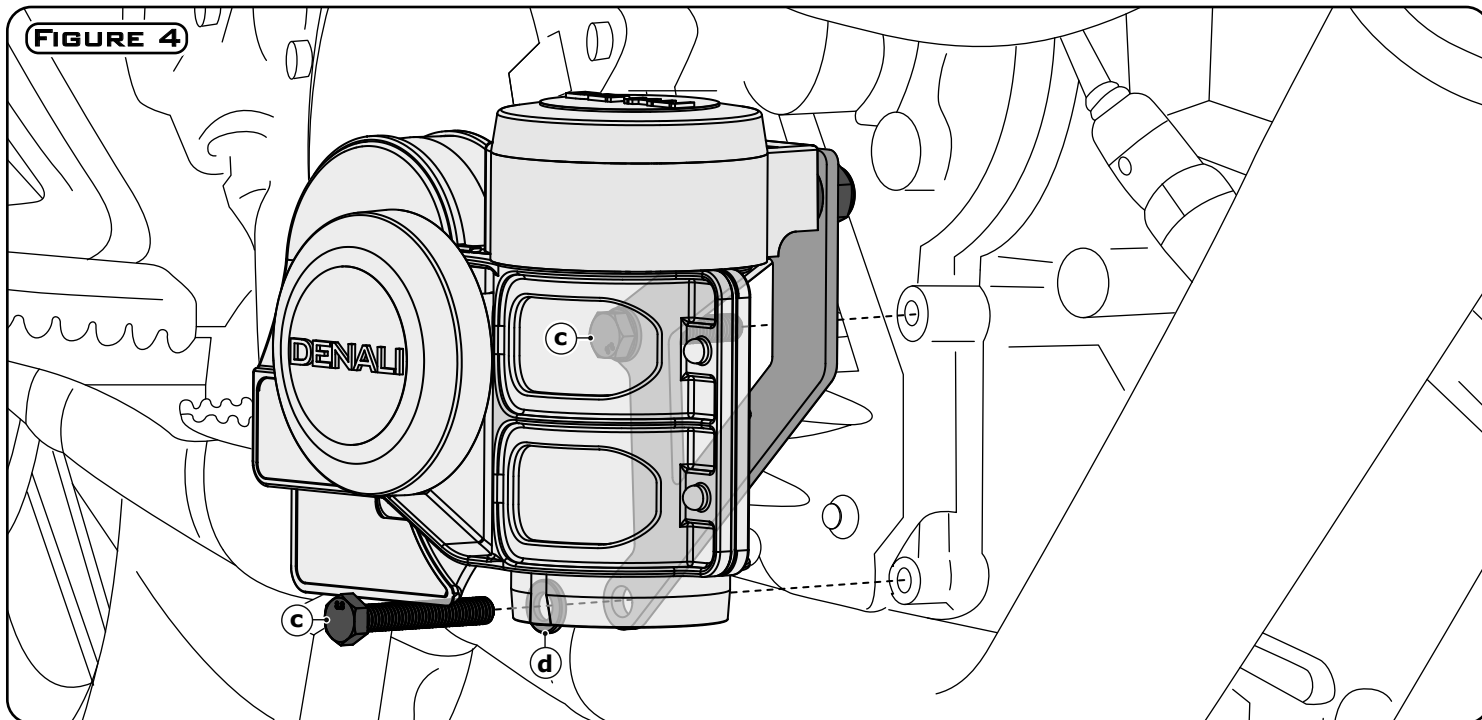

Mounting The Horn Assembly To The Motorcycle

Step Four: Insert the M6x35 bolt (c) through a M6 washer (d) and the lower 6mm hole of bracket (a).

Step Five: Mount the assembled horn and bracket to the motorcycle, the upper bolt (b) will need to be tightened before the lower bolt (c). Torque each bolt (b & c) to 6.5 ft-lbs.

Step Six: Refer to the SoundBomb Compact Horn instruction manual for step by step wiring instructions.

Step Seven: Before operating the motorcycle, turn the handlebars fully left, right and fully compress the suspension. Confirm that the wires do not interfere with operation and that they have enough slack to account for all suspension and steering movement.