



YOSHIMURA

RESEARCH&DEVELOPMENT OF AMERICA, INC.

5420 DANIELS STREET STE A, CHINO CA., 91710 · (800) 634-9166 · (909) 628-4722 · FACSIMILE (909) 591-2198

www.yoshimura-rd.com

Signature Series

Qualified Manufacturer Declared "Replacement Part"

2018

Honda CRF250R

22843AR520 (SS/SS)

22843PR720 (Ti/Ti)

RS-9 Taper Full-System

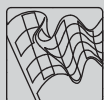

Signature Series systems are:

- CARB/EPA tail-pipe emissions compliant.
- Marked with appropriate EPA noise labels.
- Independent laboratory tested for EPA new vehicle noise compliance.

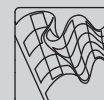

✘ You must know how to remove and replace your stock exhaust in order to install this product otherwise have it installed by a professional mechanic. Keep all stock parts from your existing system as some components may be necessary to install your new Yoshimura exhaust depending on the application. Read through all instructions before beginning installation. Exhaust system can be extremely hot. Let motorcycle cool down before beginning installation. Always wear hand and eye protection and take precautionary measures to avoid injury. ✘

NOTE: IN THE STATE OF CALIFORNIA, IT IS ILLEGAL TO MODIFY THE EMISSION CONTROL SYSTEM, WHICH INCLUDES THE CARBURETORS OF ANY VEHICLE.

Assembly Diagram

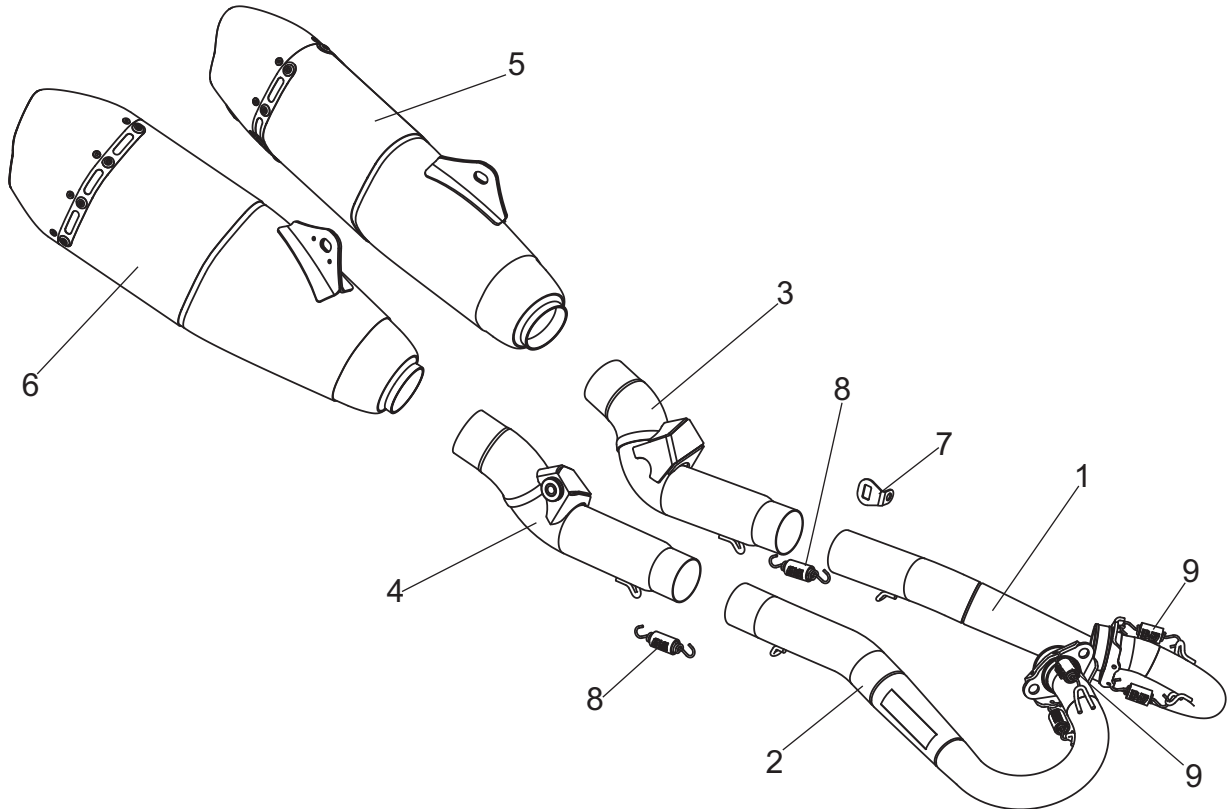

No.	Item	Description	Qty.
1	22843-104F 22843-704F	Yoshimura SS Header Kit, Left Yoshimura Ti Header Kit, Left	1
2	22843-105F 22843-705F	Yoshimura SS Header Kit, Right Yoshimura Ti Header Kit, Right	1
3	22843-144 22843-744	Yoshimura SS Tailpipe, Left Yoshimura Ti Tailpipe, Left	1
4	22843-145 22843-745	Yoshimura SS Tailpipe, Right Yoshimura Ti Tailpipe, Right	1
5	22843AR520-LMA 22843PR720-LMA	Yoshimura SS Muffler, Left Yoshimura Ti Muffler, Left	1
6	22843AR520-RMA 22843PR720-RMA	Yoshimura SS Muffler, Right Yoshimura Ti Muffler, Right	1
7	22843-CLPBKT	Wire Clip Bracket	1
8	RACE-SPS-1	Medium Exhaust Spring	2
9	RACE-SPX-1	Small Exhaust Spring	4
**	05747076	3mm Hex Key	1
**	ST-200	Spring Puller Tool	1
**	17029	Sticker Kit Sheet	1

** Not shown in diagram.

CAUTION: Exhaust system can be extremely hot. Let motorcycle cool down before beginning installation. Always wear hand and eye protection and take precautionary measures to avoid injury.

WARNING: Always properly support vehicle with a stand and/or lift when servicing or performing any work. Unstable vehicles may present dangerous conditions and may cause property damage and/or personal injury.

NOTE: Read through all instructions before beginning installation.

Removal

1. Remove rider seat.
2. Remove the left and right side panels.
3. Loosen the left and right muffler exhaust clamps.
4. While securely supporting the left muffler assembly, remove the left side muffler chassis mount bolt and muffler mount bolt. Carefully remove the stock muffler assembly by sliding toward the rear.
5. While securely supporting the right muffler assembly, remove the right side muffler chassis mount bolt and muffler mount bolt. Carefully remove the stock muffler assembly by sliding toward the rear.
6. Remove left and right header nuts and carefully remove the stock headers.

Note: The stock exhaust port gasket will be re-used with the Yoshimura full-system. Inspect and replace if necessary.

7. Unbolt wire clip from engine located on the left side and remove.



Installation

1. Install (No. 7) 22843-CLPBKT, wire clip bracket onto engine using the stock bolt. Torque to factory specification.

Note: Bracket must be installed before installing wire clip into bracket.



2. Separate manifolds and flanges from header kits.

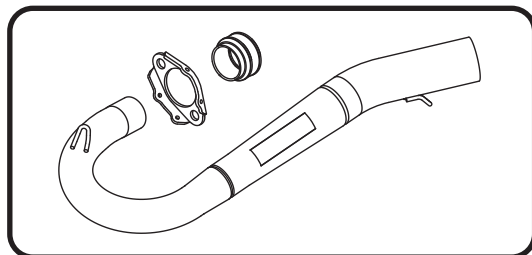

3. Install manifold and flange using the stock header nuts. Torque evenly to factory specifications.

Note: Hook (No. 9) RACE-SPX-1, small exhaust springs onto flange before installing header to ease installation. See below for proper spring hole locations.

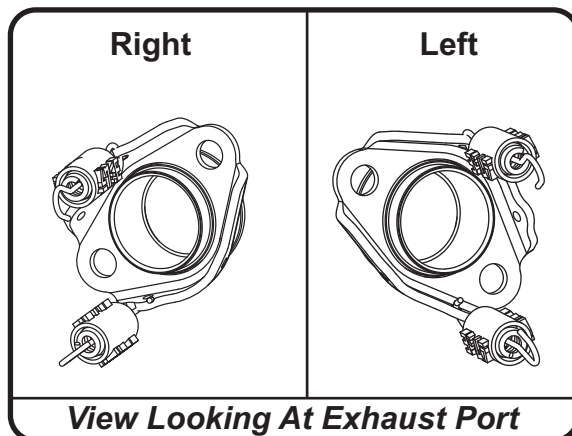

4. Install (No. 1) 22843-104/704, left header into manifold and hook (No. 9) RACE-SPX-1, small exhaust spring onto header using ST-200, spring puller tool supplied in the kit.

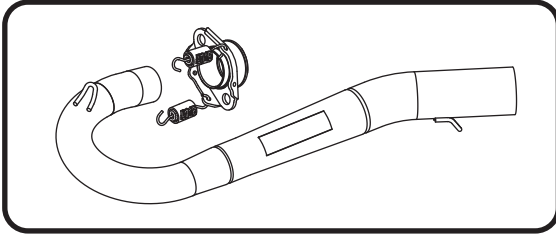

5. Install (No. 1) 22843-105/705, right header into manifold and hook (No. 9) RACE-SPX-1, small exhaust spring onto header using ST-200, spring puller tool supplied in the kit.

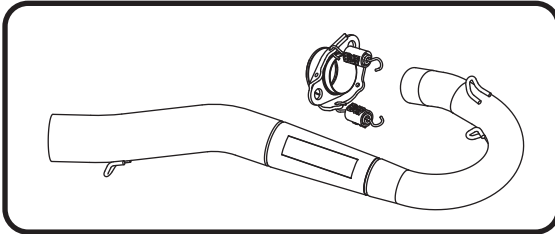

6. Install (No. 3) 22843-144/744, left tailpipe onto (No. 1) 22843-104/704, header outlet and align tailpipe chassis mount bracket to chassis mount. Secure using the stock chassis mount bolt. Do not torque at this time.

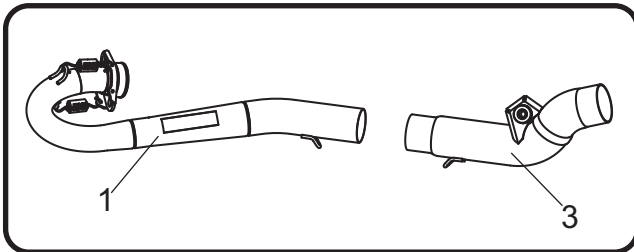

7. Install (No. 5) left muffler, over (No. 3) 22843-144/744, left tailpipe outlet. Align muffler mount bracket to muffler mount and secure using the stock muffler mount bolt and washer. Torque to factory specification.

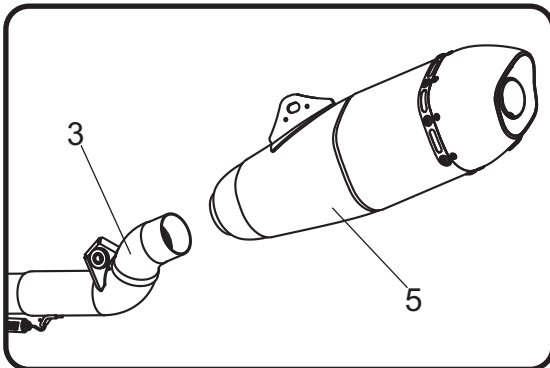

8. Torque tailpipe chassis mount bolt to factory specification and install (No. 8) RACE-SPS-1, medium exhaust spring between tailpipe and header as shown on the assembly diagram.

9. Install (No. 4) 22843-145/745, right tailpipe onto (No. 2) 22843-105/705, header outlet and align tailpipe chassis mount bracket to chassis mount. Secure using the stock chassis mount bolt. Do not torque at this time.

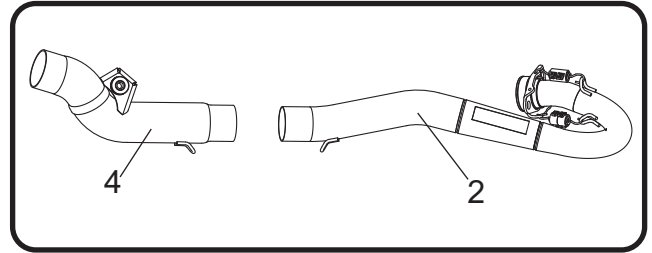

10. Install (No. 6) right muffler, over (No. 4) 22843-145/745, right tailpipe outlet. Align muffler mount bracket to muffler mount and secure using the stock muffler mount bolt and washer. Torque to factory specification.

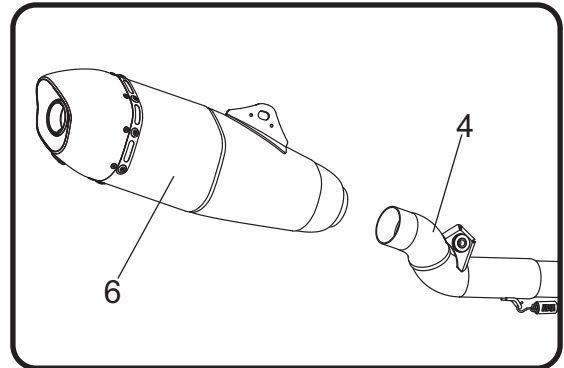

11. Torque tailpipe chassis mount bolt to factory specification and install (No. 8) RACE-SPS-1, medium exhaust spring between tailpipe and header as shown on the assembly diagram.
12. Re-install left and right side panels following the opposite steps of removal.
13. Before starting motorcycle, check for proper clearance between new exhaust system and rear suspension (i.e. tire, swingarm, brakes, rear shock, and etc.) If any problem is found, please carefully follow through the installation steps again. If problem still persists, please call Yoshimura Tech Department at (800) 634-9166 / in CA (909) 628-4722.
14. It is recommended that the muffler and tailpipe be wiped down with rubbing alcohol to remove oil and fingerprints. This will help prevent tarnishing of the finish after the exhaust is heated up.

Note: After starting motorcycle, it is normal for new exhaust system and muffler to emit smoke until oil residue burns off.