



YOSHIMURA

RESEARCH&DEVELOPMENT OF AMERICA, INC.

5420 DANIELS STREET STE A, CHINO CA., 91710 · (800) 634-9166 · (909) 628-4722 · FAX (909) 591-2198

www.yoshimura-rd.com

Street Series

Qualified Manufacturer Declared "Replacement Part"

2017
SUZUKI GSX-R 1000
11182BP520 (SS/CF)
11182MP720 (TI/CF)
Alpha Taper Slip-On

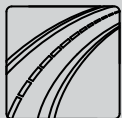

All Street Series systems are:

- Slip-on/Bolt-on applications that do not require tampering with the vehicle's emissions control system.
- CARB/EPA tail-pipe emissions compliant.
- Marked with appropriate EPA noise labels.
- Not tested for EPA new vehicle noise compliance.



✘ You must know how to remove and replace your stock exhaust in order to install this product otherwise have it installed by a professional mechanic. Keep all stock parts from your existing system as some components may be necessary to install your new Yoshimura exhaust depending on the application. Read through all instructions before beginning installation. Exhaust system can be extremely hot. Let motorcycle cool down before beginning installation. Always wear hand and eye protection and take precautionary measures to avoid injury. ✘

NOTE: IN THE STATE OF CALIFORNIA, IT IS ILLEGAL TO MODIFY THE EMISSION CONTROL SYSTEM, WHICH INCLUDES THE CARBURETORS OF ANY VEHICLE.

Assembly Diagram

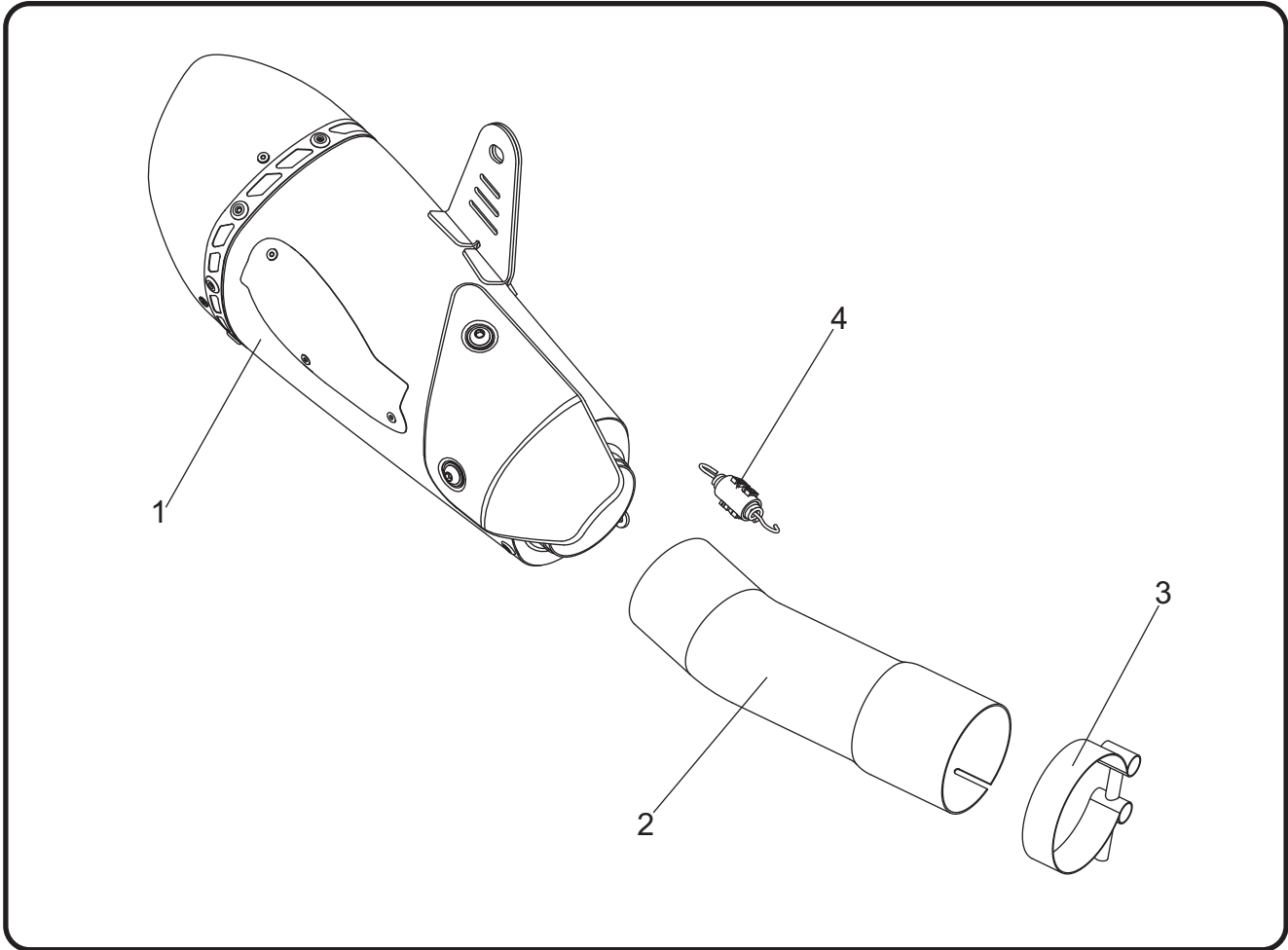

No.	Item	Description	Qty.
1	11182BP520-RMA 11182MP720-RMA	Yoshimura Stainless Steel Muffler Assembly Yoshimura Titanium Muffler Assembly	1
2	11182-435D 11182-735D	Yoshimura Stainless Steel Tailpipe Yoshimura Titanium Tailpipe	1
3	20069	Exhaust Clamp	1
4	RACE-SPS-1	Medium Exhaust Spring	1
**	ST-200	Spring Puller Tool	1
**	INS-20-K	Low Volume Sound Insert	1
**	17029	Sticker Sheet	1

** Not Shown on diagram.

CAUTION: Exhaust system can be extremely hot. Let motorcycle cool down before beginning installation. Always wear hand and eye protection and take precautionary measures to avoid injury.

WARNING: Always properly support vehicle with a stand and/or lift when servicing or performing any work. Unstable vehicles may present dangerous conditions and may cause property damage and/or personal injury.

NOTE: Read through all instructions before beginning installation.

Removal

1. Loosen the stock exhaust clamp between the header and muffler joint.
2. While securely supporting the stock muffler, remove the muffler mount bolt and carefully remove the stock muffler assembly.

Note: The stock exhaust gasket will not be used with the Yoshimura system.

Installation

1. Install (No. 2) 11182-435D/11182-735D, tailpipe outlet into (No. 1) *muffler*, inlet.
2. Slide (No. 3) 60069, exhaust clamp over (No. 2) 11182-435D/11182-735D, tailpipe inlet as shown. Do not torque clamp at this time.

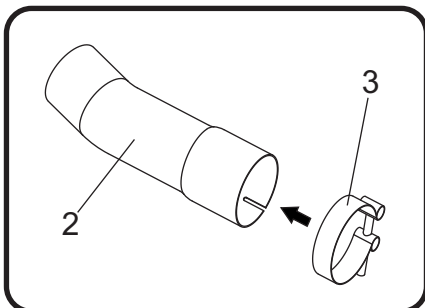

3. Install (No. 2) 11182-435D/11182-735D, tailpipe over the stock header outlet and align muffler bracket to the frontside of muffler mount as shown. Secure using the stock muffler mount bolt, washer, and nut. .

Note¹: Slide tailpipe past the header stopper ring.

Note²: It may be necessary to rotate the muffler and tailpipe independently to achieve proper alignment.

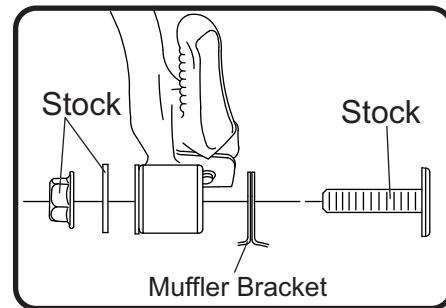

4. Torque muffler mount bolt to factory specification.
5. Install (No. 4) *RACE-SPS-1*, medium exhaust spring between muffler and tailpipe using the *ST-200*, spring puller tool supplied in the kit.
6. Torque (No. 3) 20069, exhaust clamp to 8.5 Nm (0.86 kg-m, 6 ft-lbs).
7. Before starting vehicle, check for proper clearance between new exhaust system and rear suspension (i.e. tire, swingarm, brakes, rear shock, and etc.) If any problem is found, please carefully follow through the installation steps again. If problem still persists, please call Yoshimura Tech Department at (800) 634-9166 / in CA (909) 628-4722.

8. It is recommended that the muffler and tailpipe be wiped down with rubbing alcohol to remove oil and fingerprints. This will help prevent tarnishing of the finish after the exhaust is heated up.

Note: After starting motorcycle, it is normal for new exhaust system and muffler to emit smoke until oil residue burns off.

Works Finish Care & Maintenance

Before starting vehicle, clean pipe thoroughly using a soft cloth and rubbing alcohol to remove any oil and finger prints.

The color of the exhaust will change once the system has gone through a heat cycle of 15 minutes or more. Color will vary depending on lean/rich conditions.

Clean using a soft cloth and soap. Do not use abrasive materials as it will scratch the surface.

Surface reconditioning services are available to remove scratches and undesirable discoloration due to extreme heat. Contact Yoshimura Tech Department at (800) 634-9166 / in CA (909) 628-4722 for more information.