



FITTING INSTRUCTIONS FOR TH0008
TRANSPORT HOOKS FOR YAMAHA R25/R3/R320 2014-



THIS KIT CONTAINS THE ITEMS PICTURED AND LABELLED BELOW.
DO NOT PROCEED UNTIL YOU ARE SURE ALL PARTS ARE PRESENT.

Please note that the way the kit is packed does not necessarily represent the way of mounting to the bike.

THE PARTS SHOWN MAY BE REPRESENTATIVE ONLY (FOR CLARITY OF INSTRUCTIONS ONLY).

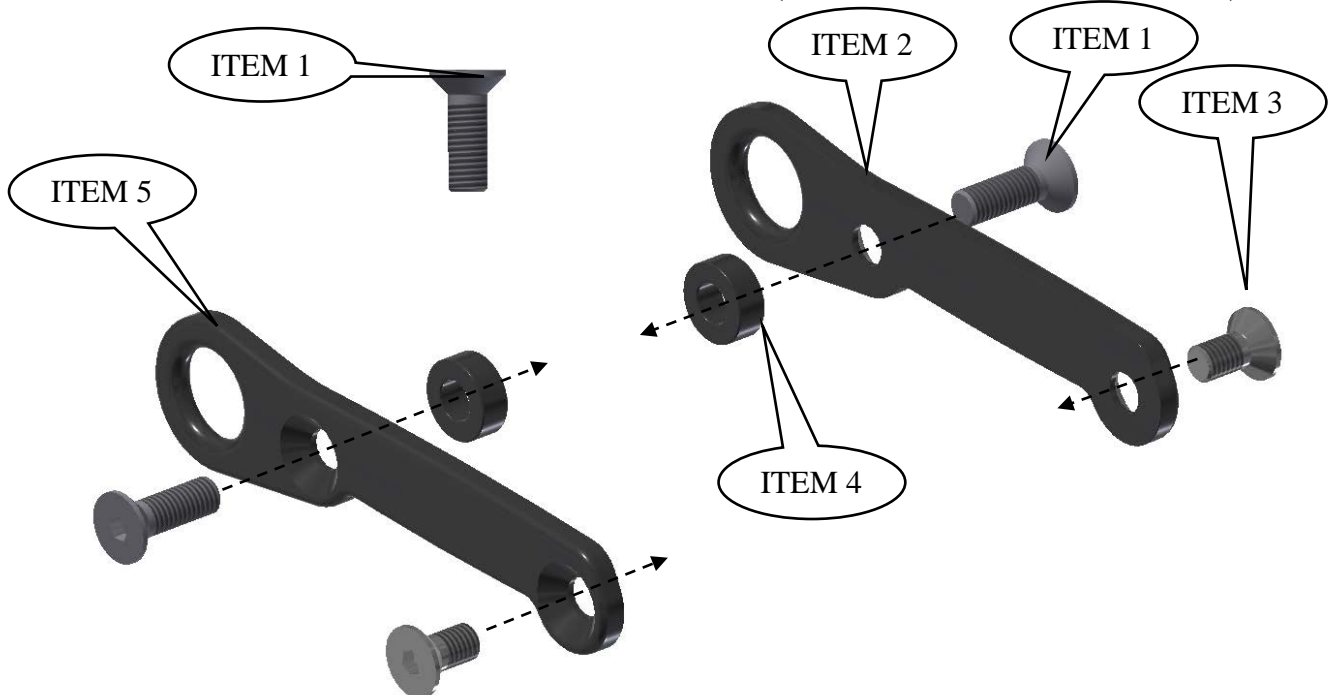



LEGEND

- ITEM 1 = TIE-DOWN HOOK LEFT HAND SIDE (SMW0064) (x1).
 ITEM 2 = TIE-DOWN HOOK RIGHT HAND SIDE (SMW0065) (x1).
 ITEM 3 = M8 x 15mm LONG COUNTERSUNK BOLTS (x2).
 ITEM 4 = M8 x 25mm LONG COUNTERSUNK BOLTS (x3).
 ITEM 5 = SPACER REAR (S0635=7.5mm WIDE) (x2).

Please note that in cases where kits are packed with rubber washers holding the components onto the bolt – *the rubber washers should be thrown away!*

TOOLS REQUIRED

- Allen Key set to include 5 & 6mm A/F.

GENERAL TORQUE SETTINGS

M4 BOLT = 8Nm
 M5 BOLT = 12Nm
 M6 BOLT = 15Nm
 M8 BOLT = 20Nm
 M10 BOLT = 40Nm

FITTING INSTRUCTIONS

- Remove the OEM pillion footrests on both sides of the bike.
 - Place one of the longer M8 counter sunk bolts (item 1) through the rear most hole in the left hand side tie-down hook (item 5) and place one of the spacers (item 4) over the exposed thread as shown above.
 - Place one of the shorter M8 counter sunk bolts (item 3) through the forward hole in the left hand side tie-down hook (item 5) as shown above.
 - Offer the assembly into position and tighten into the thread on the subframe.
 - On the right hand side, the transport hook can only be fitted when the original exhaust hanger bracket is not fitted or when an R&G exhaust hanger is fitted, available separately (part No EH0063).
 - With the R&G Exhaust Hanger fitted, remove the two top bolts that mount the hanger to the subframe.
 - Offer the right hand side R&G transport hook (item 2) with the remaining spacer (item 4) into position on the bike and tighten into the thread on the subframe using the two remaining M8 x 25mm long countersunk bolts (item 1) as shown above.
 - If the R&G exhaust hanger is not fitted use one of the shorter M8 counter sunk bolts and one of the longer M8 counter sunk bolts with the spacer.
 - Ensure the part is correctly fitted before tightening all bolts to the recommended torque values.
- We recommend that fabric from the straps be in contact with the product, as opposed to the hook on the end of the strap. This will increase the lifespan of the protective coating on the product.
- Do not overtighten straps attached to the product, as it would be possible to bend or break the product with excessive force. If in any doubt please consult a professional.
- R&G cannot be held liable for any breakages to straps, or consequential damage from this, as a result of fraying/breaking of the straps, or incorrect use. Please ensure that all bodywork of the motorcycle which may come in contact with the straps (e.g. plastic panels, exhausts, swingarms) are protected or left completely clear of the straps.



- While we may show certain applications where the product is being used for attaching luggage to a motorcycle, this is not a general recommendation and cannot be achieved on all motorcycles.
- Care and attention needs to be taken whenever the product is in use for securing luggage or for tying the motorcycle down. R&G cannot accept any responsibility for inappropriate use or decisions on the part of the user. If in doubt, always consult a professional.

ISSUE 1 13/02/2017 (NSY)

Digital copies of these instructions are available to download from www.rg-racing.com

CONSUMER NOTICE

The catalogue description and any exhibition of samples are only broad indications of the Products and R&G may make design changes which do not diminish their performance or visual appeal and supplying them in such state shall conform to the order. The Buyer acknowledges no representation or warranty (other than as to title) has been given or will apply to the Products other than those in R&G's order or confirmation and the Buyer confirms it has chosen the Products as being of merchantable quality and suitable for its particular purposes. Where R&G fits the Products or undertakes other services it shall exercise reasonable skill and care and rectify any fault free of charge unless the workmanship has been disturbed. The Buyer is responsible for ensuring that the warranty on the motorcycle is not affected by the fitting of the Products. On return of any defective Products R&G shall at its option either supply a replacement or refund the purchase money but shall not be liable if the Products have been modified or used or maintained otherwise than in accordance with R&G's or manufacturer's instructions and good engineering practice or if the defect arises from accident or neglect. Other than identified above and subject to R&G not limiting its liability for causing death and personal injury, it shall not be liable for indirect or consequential loss and otherwise its liability shall be limited to the amounts paid by the Buyer for the Products or the fitting or service concerned. These terms do not affect the Buyer's statutory rights.

R&G RACING RETURNS POLICY (NON-FAULTY GOODS)

Returns must be pre-authorized (if not pre-authorized the return will be rejected). Goods may only be returned direct to us if they were purchased direct from us (customer must prove if necessary). Otherwise to be returned to original vendor. Goods must be in re-sellable condition, in the opinion of R&G Racing. All returns are subject to a 25% restocking and handling fee (25% of the gross value exc. P&P – at the prevailing price at time of purchase). The customer must pay any and all carriage charges. No returns of discontinued products, unless within 14 days of purchase. This policy does not affect your statutory rights and does not refer to faulty goods.



NOTICE DE MONTAGE POUR TH0008
ATTACHES DE TRANSPORT POUR YAMAHA R25/R3/R320 2014-



Le kit contient les articles exposés ci-dessous, vérifier que toutes les pièces soient présentes avant de procéder au montage.

La façon dont le kit est emballé ne correspond pas forcément à la façon de monter les pièces sur la moto.

LES PARTIES PRESENTEES PEUVENT ETRE UNIQUEMENT REPRESENTATIVES (POUR LA CLARTE DES INSTRUCTIONS UNIQUEMENT).

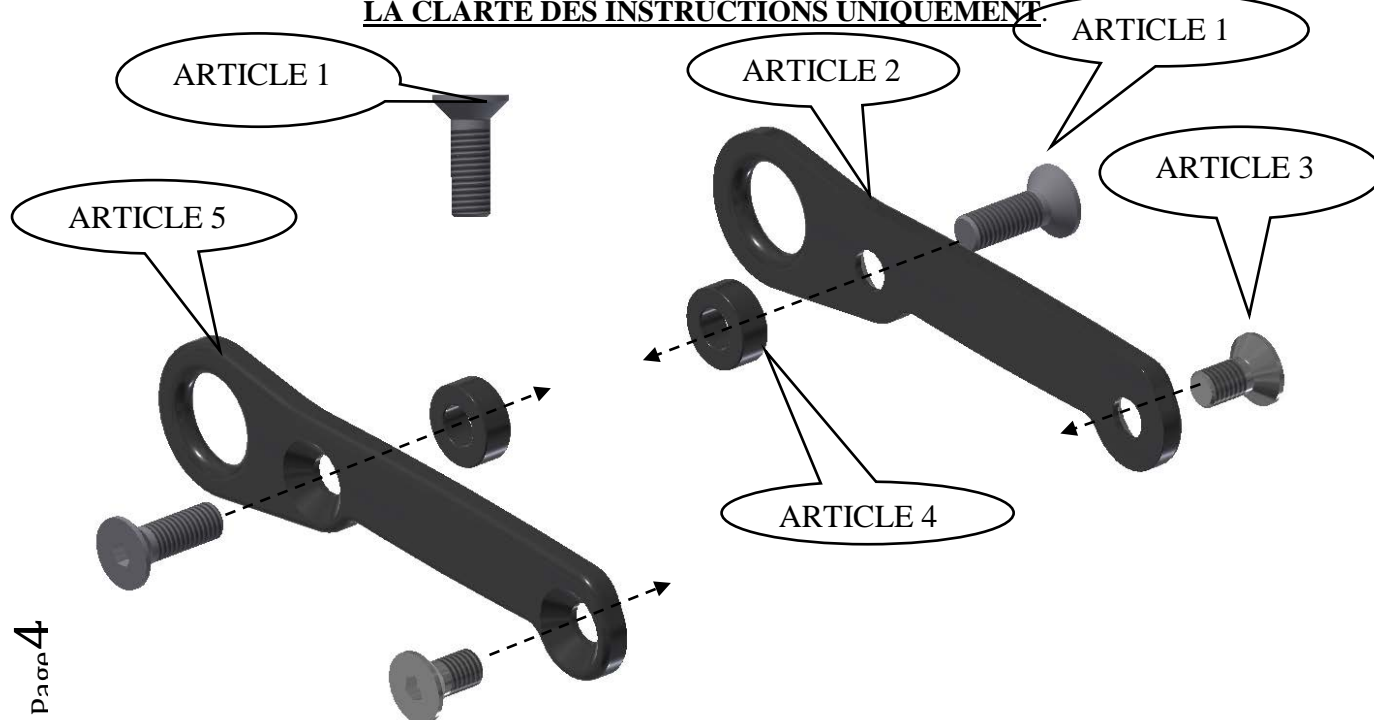



LEGENDE

ARTICLE 1 = ATTACHE DE TRANSPORT COTE GAUCHE (SMW0064) (x1).

ARTICLE 2 = ATTACHE DE TRANSPORT COTE DROIT (SMW0065) (x1).

ARTICLE 3 = M8 x 15mm BOULONS (x2).

ARTICLE 4 = M8 x 25mm BOULONS (x3).

ARTICLE 5 = ENTRETOISE ARRIERE (S0635=7.5mm DE LARGE) (x2).

Notez que si les kits sont emballés avec des rondelles en caoutchouc servant à tenir les composants, *ces rondelles doivent être jetées!*

OUTILS REQUIS

- Clés Allen 5 & 6mm.

COUPLES DE SERRAGE RECOMMANDÉS

M4 BOULON = 8Nm

M5 BOULON = 12Nm

M6 BOULON = 15Nm

M8 BOULON = 20Nm

M10 BOULON = 40Nm

NOTICE DE MONTAGE

- Enlever les repose pieds d'origine des 2 cotés de la moto.
 - Placer un des boulons M8 (article 1) dans le trou le plus à l'arrière du crochet d'arrimage gauche (article 5) et placer une des entretoises (article 4) sur le filetage exposé, voir ci-dessus.
 - Placer un des boulons M8 (article 3) dans le trou le plus à l'avant du crochet d'arrimage du coté gauche (article 5) voir ci-dessus.
 - Monter l'ensemble en position puis serrer dans le filetage du sous-cadre.
 - Du coté droit, l'attache de transport ne peut être montée que lorsque le support d'échappement d'origine est retiré ou lorsqu'un support R&G est monté, disponible séparément (partie No EH0063).
 - Avec le support d'échappement R&G monté, enlever les 2 boulons supérieurs qui fixent le support au sous-cadre.
 - Monter l'attache de transport R&G du coté droit (article 2) avec l'entretoise restante (article 4) en position sur la moto puis serrer dans le filetage du sous-cadre en utilisant les 2 boulons restants M8 x 25mm (article 1) voir ci-dessus.
 - Si le support d'échappement R&G n'est pas monté, utiliser un des boulons M8 les plus courts et un des boulons M8 les plus longs avec l'entretoise.
 - Veiller à ce que le produit soit correctement monté avant de serrer tous les boulons aux valeurs de serrage recommandées.
- Nous recommandons que le tissu des sangles soit en contact avec le produit, Par opposition au crochet sur l'extrémité de la sangle. Cela augmente la durée de vie du revêtement protecteur présent sur le produit.



- Ne pas trop serrer les sangles attachées au produit, car cela pourrait plier ou casser le produit avec si la force est excessive. En cas de doute, consulter un professionnel.
- R & G ne peut être tenu pour responsable des bris de sangles, ou des dommages consécutifs à cela, en raison de l'effilochage / rupture des sangles, ou de l'utilisation incorrecte. Veillez à ce qu'aucune partie de la moto ne puisse entrer en contact avec les sangles (par exemple les panneaux en plastique, les échappements, les bras oscillants) et soit protégée ou laissée complètement à l'écart des sangles.
- Bien que nous puissions montrer certaines applications où le produit est utilisé pour attacher des bagages à une moto, ce n'est pas une recommandation générale, elle ne peut donc pas être réalisée sur toutes les motos.

Des précautions doivent être prises lorsque le produit est utilisé pour sécuriser les bagages ou pour attacher la moto. R&G décline toute responsabilité en cas d'utilisation inappropriée ou de décision inappropriée de la part de l'utilisateur. En cas de doute, consultez toujours un professionnel.

ISSUE 1 13/02/2017 (NSY)

Notice disponible au téléchargement sur www.rg-racing.com
CONSUMER NOTICE

The catalogue description and any exhibition of samples are only broad indications of the Products and R&G may make design changes which do not diminish their performance or visual appeal and supplying them in such state shall conform to the order. The Buyer acknowledges no representation or warranty (other than as to title) has been given or will apply to the Products other than those in R&G's order or confirmation and the Buyer confirms it has chosen the Products as being of merchantable quality and suitable for its particular purposes. Where R&G fits the Products or undertakes other services it shall exercise reasonable skill and care and rectify any fault free of charge unless the workmanship has been disturbed. The Buyer is responsible for ensuring that the warranty on the motorcycle is not affected by the fitting of the Products. On return of any defective Products R&G shall at its option either supply a replacement or refund the purchase money but shall not be liable if the Products have been modified or used or maintained otherwise than in accordance with R&G's or manufacturer's instructions and good engineering practice or if the defect arises from accident or neglect. Other than identified above and subject to R&G not limiting its liability for causing death and personal injury, it shall not be liable for indirect or consequential loss and otherwise its liability shall be limited to the amounts paid by the Buyer for the Products or the fitting or service concerned. These terms do not affect the Buyer's statutory rights.

R&G RACING RETURNS POLICY (NON-FAULTY GOODS)

Returns must be pre-authorized (if not pre-authorized the return will be rejected). Goods may only be returned direct to us if they were purchased direct from us (customer must prove if necessary). Otherwise to be returned to original vendor. Goods must be in re-sellable condition, in the opinion of R&G Racing. All returns are subject to a 25% restocking and handling fee (25% of the gross value exc. P&P – at the prevailing price at time of purchase). The customer must pay any and all carriage charges. No returns of discontinued products, unless within 14 days of purchase. This policy does not affect your statutory rights and does not refer to faulty goods.