

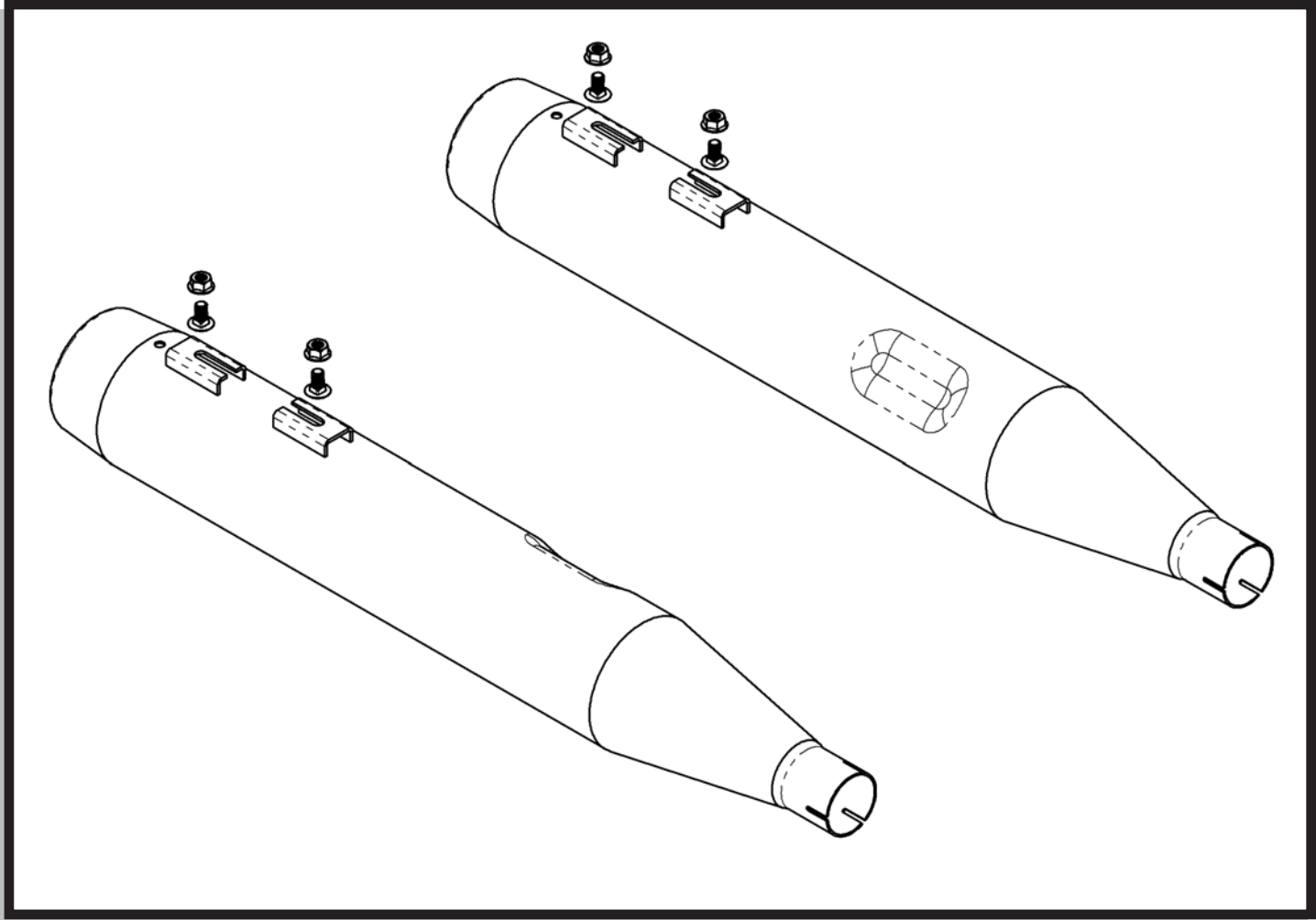

**RCX102C**

**4.0" SLIP-ON EXHAUST**

**1995-UP ALL TOURING FLH**



**PARTS INCLUDED**

Ref.	Part Number	Description	Qty
1)	00-300-02265	Muffler Assembly, Right	1
2)	00-300-02266	Muffler Assembly, Left	1
3)	01-13051805-27	Carriage Bolt, 5/16-18x5/8"	4
4)	01-340518-27	Hex Flange Nut, 5/16-18	4

08-50-46806 REV. C



373 Mitch McConnell Way • Bowling Green, Kentucky 42101 • 1-800-360-0915  
fax: 270-842-9527 • email: rcc@rccomponents.com

[www.rccomponents.com](http://www.rccomponents.com)

**RCX102C**

**4.0" SLIP-ON EXHAUST**

**1995-UP ALL TOURING FLH**

**NOTE**

RCX exhaust systems may not meet EPA and/or carb emissions in the State of California or other States with similar emission control restrictions. End user of product shall determine acceptable use in compliance with local and federal laws. User of product assumes all risk and financial obligations in violation of such regulations as a result of vehicle inspections or emission tests.

**INSTALLATION INSTRUCTIONS**

- 1) Make sure the motorcycle is cool and place securely on a service lift or center stand.
- 2) Loosen the bolt securing the clamp to the right side stock muffler inlet.
- 3) Remove the two nuts securing the right side muffler to the lower saddlebag support frame.
- 4) Carefully slide the stock muffler off of the headpipe and set aside.
- 5) Loosely place factory muffler clamp onto the new right side muffler inlet.
- 6) Slide the new muffler onto the right side headpipe outlet. Do not tighten clamp at this time.
- 7) Using two supplied 5/16-18x5/8" carriage bolts, and two 5/16-18 hex flange nuts, secure the muffler to the lower saddlebag support frame. Do not fully tighten bolts at this time.
- 8) Position the right side slip-on muffler assembly. Fully tighten the muffler mounting bolts, then the muffler inlet clamp.
- 9) Repeat steps 2-8 for left side muffler installation.

**BILLET ALUMINUM END CAP INSTRUCTIONS – if installing separately**

- 1) Due to tightness tolerances it may be necessary to use a rubber mallet or deadblow hammer to tap into position.
- 2) Fasten with provided screws to secure.



373 Mitch McConnell Way • Bowling Green, Kentucky 42101 • 1-800-360-0915  
fax: 270-842-9527 • email: rcc@rccomponents.com

**www.rccomponents.com**