



YOSHIMURA

RESEARCH&DEVELOPMENT OF AMERICA, INC.

5420 DANIELS STREET STE A, CHINO CA., 91710 · (800) 634-9166 · (909) 628-4722 · FAX (909) 591-2198

www.yoshimura-rd.com

FENDER ELIMINATOR KIT

070BG127550
Honda Transalp

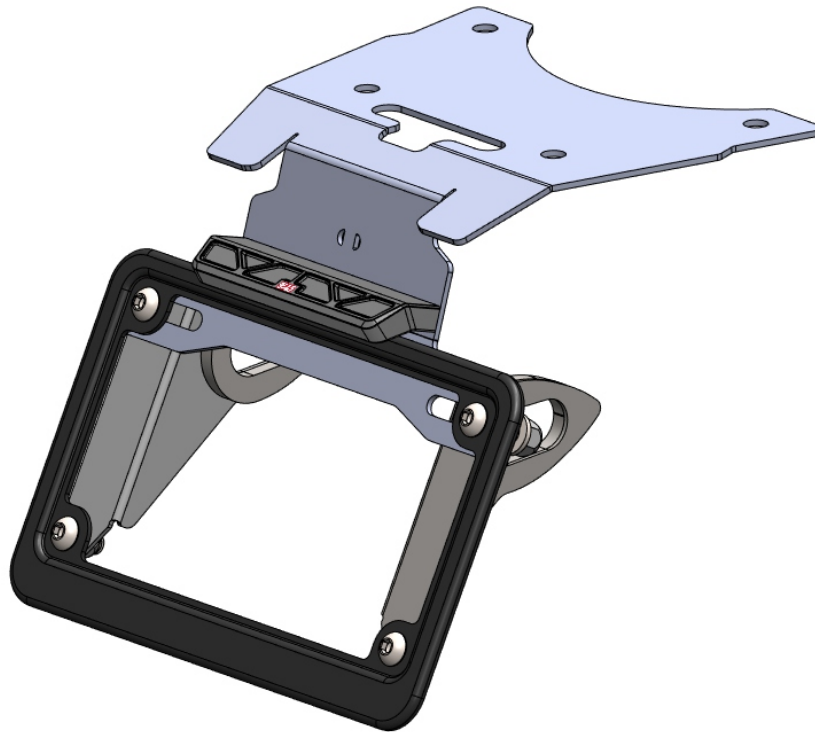

THIS PRODUCT IS NOT DOT APPROVED.

Yoshimura R&D of America, Inc. is not liable or responsible for any resulting event caused by the installation of this product. Check with local laws and regulations for compliance prior to installation and use. This product is not intended for use on public highways.



x1

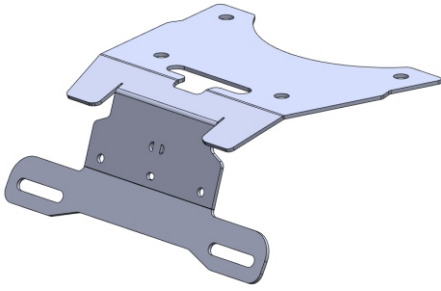

12755-FEBKT
Fender Eliminator Bracket

x1

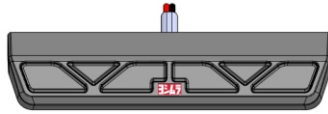

070BG-LH-K1
License Plate Light

x1



070BG-LPF
License Plate Frame

x1



12200-TSB-L
Left Turn Signal Bracket

x1



12200-TSB-R
Right Turn Signal Bracket

x2



M6X16BHS
6mm x 16mm
Button Head Screw

x2



M6X14BHS
6mm x 14mm
Button Head Screw

x4



6MMWASHER
6mm Washer

x4

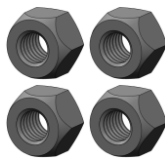

6MMLN
6mm Lock Nut

x1



ZT-400
Cable Tie

x2

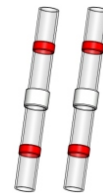

BN-SSS-22-18
Solder Shrink Connector

x2



M4X6BHS
4mm x 6mm
Button Head Screw

Assembly Diagram

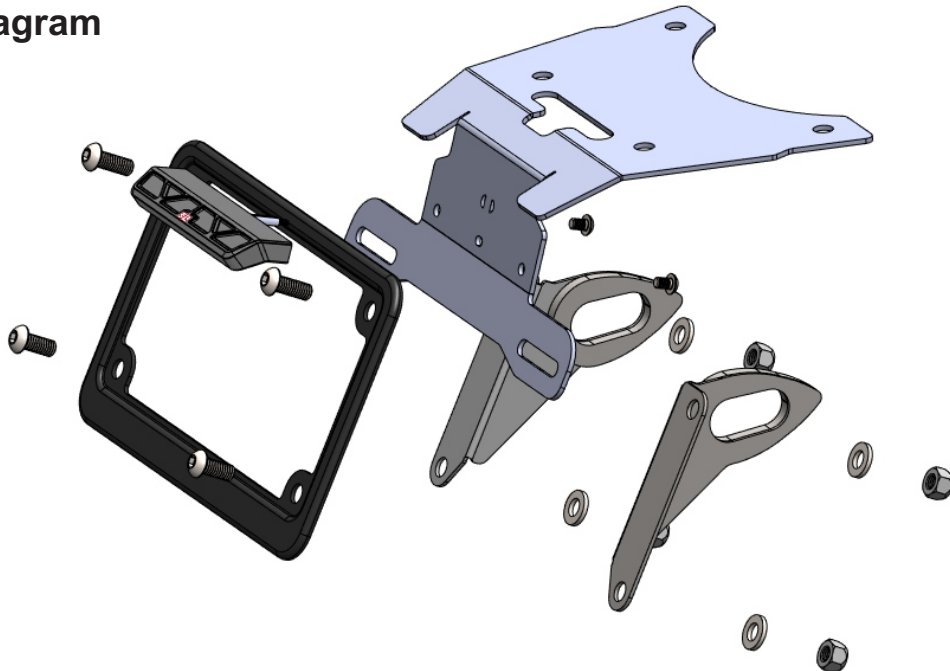

Removal

1. Remove seat.
2. Locate and disconnect the license plate light and turn signal connectors.

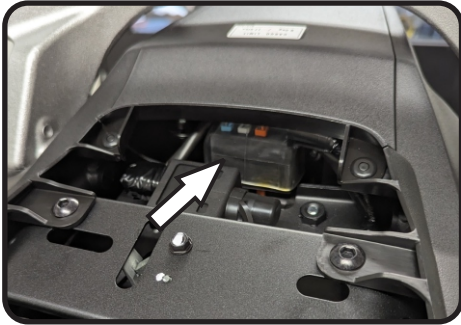

3. While securely supporting the stock fender assembly, remove the four bolts securing the stock fender and carefully remove the stock fender assembly making sure not to damage license plate light and turn signal connectors.

Note: The fender is held on by a tab to the undertail. Carefully unclip from undertail to remove.

4. Disassemble the stock fender assembly and remove left and right turn signals.
5. Cut the stock license plate light connector from the stock fender assembly. Be sure to cut at least a 6" section of wire from the connector.

Installation

1. Install *070BG-LH-K1*, Yoshimura license plate light onto *12755-FEBKT*, Yoshimura fender eliminator bracket using *M4X6BHS*, 4mm button head screws provided in the kit.

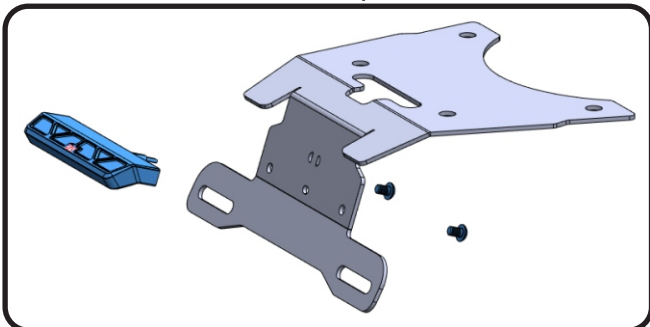

2. Using the *BN-SSS-22-18*, solder shrink connectors supplied in the kit, connect Yoshimura license plate light wires to the stock license plate light wires as follows:

Red -to- Brown
Black -to- Green

- a) Strip the stock fender light wire ends 1/4" - 1/2" and insert into *BN-SSS-22-18*, solder shrink connectors provided in the kit.
- b) Center the spliced wire ends in the middle and using a heatgun or lighter, apply heat evenly on the outer edges of the solder connector to shrink and hold wires in place.
- c) Making sure that the stripped ends are centered, heat the center of the solder connector evenly until the solder begins to liquify.
- d) Allow to cool completely and tug both ends of the wires to verify that connection is secured.

Scan for link to solder shrink connector instruction video.



3. Install the stock left and right turn signals onto *12200-TSB-L/R*, turn signal brackets.
4. Install *12200-TSB-L/R* left and right turn signal brackets and *070BG-LPF*, license plate frame using *M6X16BHS* & *M6X14BHS*, 6mm screws, *6MMWASHER*, washers, and *6MMLN*, nuts as shown below.

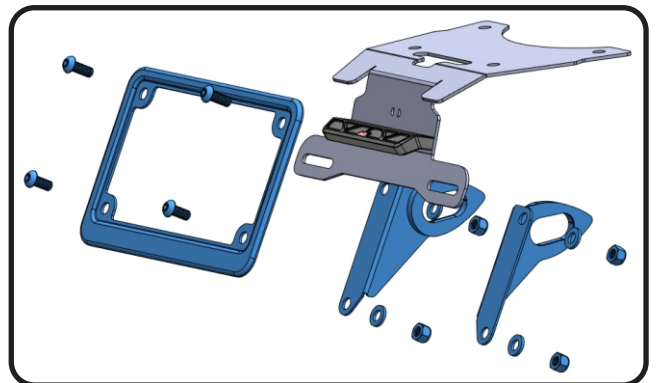

5. Route license plate light and turn signal wires through hole in fender bracket. Then continue to route license plate light wire and turn signal wires through hole in undertail and re-connect connectors.

6. Secure fender eliminator bracket assembly to frame using the four stock fender bolts. Torque fender bolts to factory specifications.
7. Secure license plate and turn signal wires to backside of *12755-FEBKT*, fender eliminator bracket using the supplied cable tie.
8. Re-install seat.
9. Check for proper function of license plate light, turn signals, brake light, and that all brackets and components are secure prior to riding.