

INSTALLATION INSTRUCTIONS: HONDA REBEL 1100T HI-OUTPUT SLIP-ON PART# 48247

Congratulations, you have purchased the finest exhaust available for your Honda Rebel 1100T. Your Vance & Hines exhaust is designed and crafted for performance, quality and style. Please follow the instructions below, check exhaust system for missing or damaged parts and if you need any assistance please contact our technical support line (562) 921-7461.

Fits: 2022 Honda Rebel 1100T

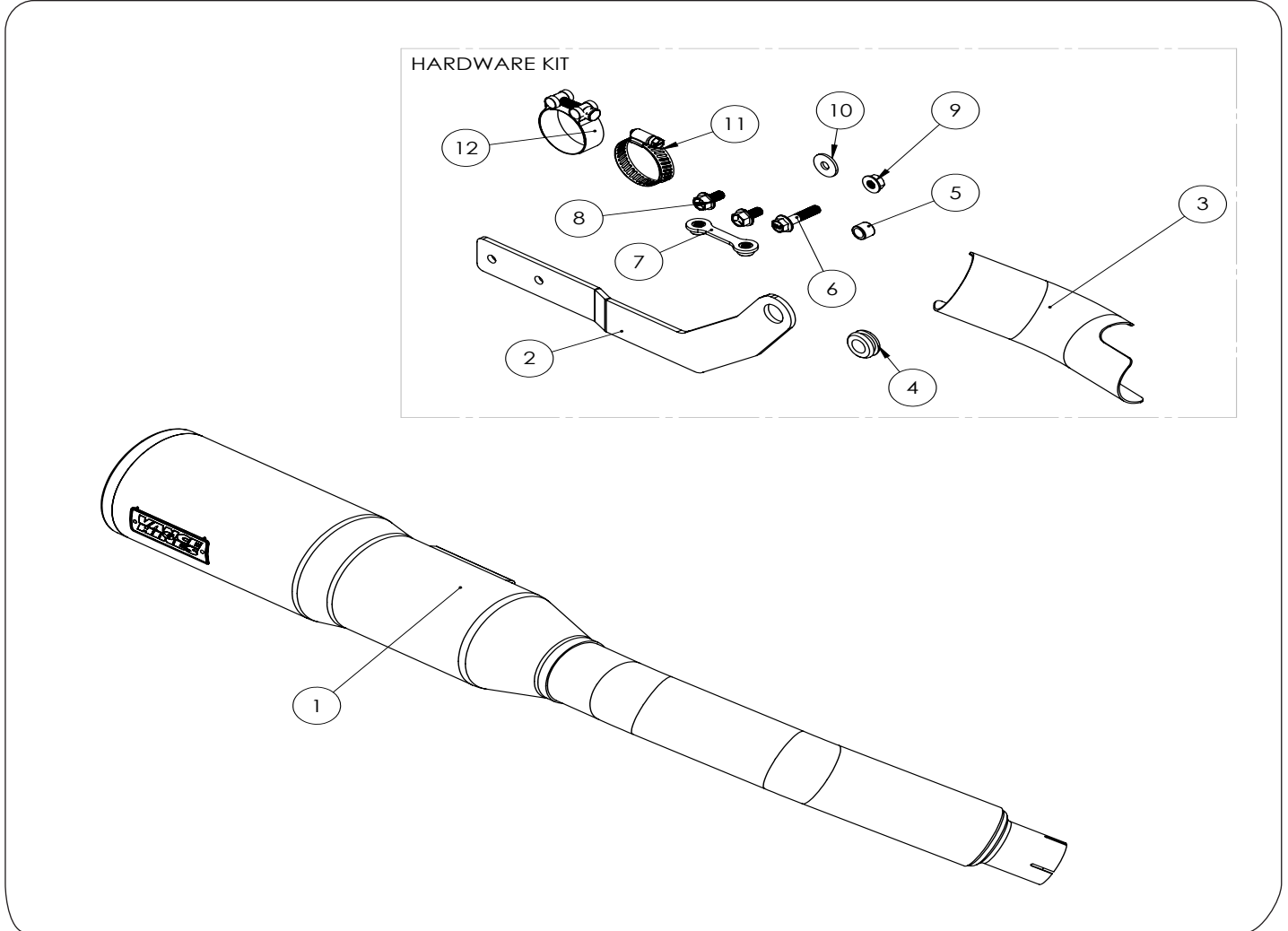

PARTS LIST

NO.	DESCRIPTION	QTY
1	SLIP-ON ASSEMBLY	1
2	MOUNTING BRACKET	1
3	HEAT SHIELD	1
4	RUBBER GROMMET	1
5	GROMMET SPACER	1
6	EXHAUST HANGAR BOLT	1

NO.	DESCRIPTION	QTY.
7	DOG BONE NUT	1
8	MUFFLER BRACKET BOLT	2
9	M8X1.25 FLANGE NUT	1
10	M8 OS WASHER ZINC	1
11	HEAT SHIELD HOSE CLAMP	1
12	EXHAUST CLAMP	1

HARDWARE

TOOLS REQUIRED

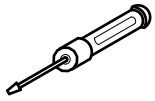

Flat Blade Screwdriver or
Nut driver

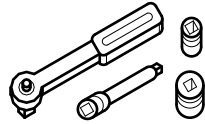

1/4" or 3/8" Drive Ratchet
3" extension and universal joint
10mm, 12mm, and 1/2" socket

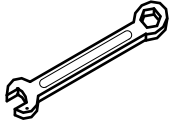

12mm combo wrench
10mm combo wrench
1/2" combo wrench

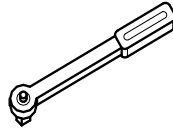

Foot-Pound Torque
Wrench

OEM SYSTEM REMOVAL

1. Loosen the clamp at the front of the muffler.
2. Remove the bolt that attaches the muffler to the stock mounting bracket.
3. remove the muffler assembly from the vehicle and remove the stock gasket from the head pipe.

V&H EXHAUST INSTALLATION

1. Install rubber grommet (4) and grommet spacer (5) into mounting bracket (2) (**FIG 1**)
2. Install the dog bon nut plate (7) and 5/16" x 5/8" flange bolts (8) to attach mounting bracket (2) to muffler (1). Hand tighten only. (**FIG 2**)
3. Slide provided barrel clamp over new V&H muffler, slip muffler onto stock mid-pipe (Leave clamp loose). Make sure that barrel clamp bolt is accessible from bottom. (**FIG 4**)
4. Line up muffler bracket (2) to bike mount and install supplied M8 x 1.25 screw (6), M8 OS washer zinc and flange nut (9). Hand tighten only. (**FIG 3**)
5. Align muffler and rotate barrel clamp to be as out of sight as possible, slign with leading edge of muffler and tighten to 17 ft-lbs.
6. Keeping muffler aligned tighten the 5/16" x 5/8" flange bolts (8) on mounting bracket then tighten M8x1.25 screw (6) and flange nut (9) securing bracket to motorcycle.
7. Install hose clamp (11) onto heat shield (3) making sure screw head is accessible when the system is installed on motorcycle for adjustment purposes. (**FIG 4**)
8. Install heat shield (3) onto muffler (1) and tighten hose clamp (**FIG 3 & 4**)
9. Be sure all hardware is tight. Before starting the motorcycle, completely clean tail pipes and mufflers with warm soapy water and a clean soft cloth that will not leave residue. Dry with a clean towel.
Note: Any residue, oil, or fingerprints will stain the finish when the exhaust system heats up. DO NOT use anything abrasive to clean black mufflers as it may remove the finish.

EXHAUST CARE (BLACK)

1. When installing a new set of black pipes, make sure your hands are clean and free from oil. After installation, thoroughly clean pipes with warm soapy water and a soft cloth. Dry with a clean towel to remove any residue before starting the motorcycle. DO NOT use anything abrasive to clean pipes.
2. Avoid long periods of idling as this can cause discoloration.
3. Intake leaks can cause the engine to run lean and overheat, this could lead to discoloration.
4. Make sure there are no exhaust leaks at the junction of the exhaust pipes and the cylinder head. We recommed replacing gaskets if they are worn.

1. FIG 1: MOUNTING BRACKET WITH HARDWARE



2. FIG 2: SLIP-ON WITH HARDWARE

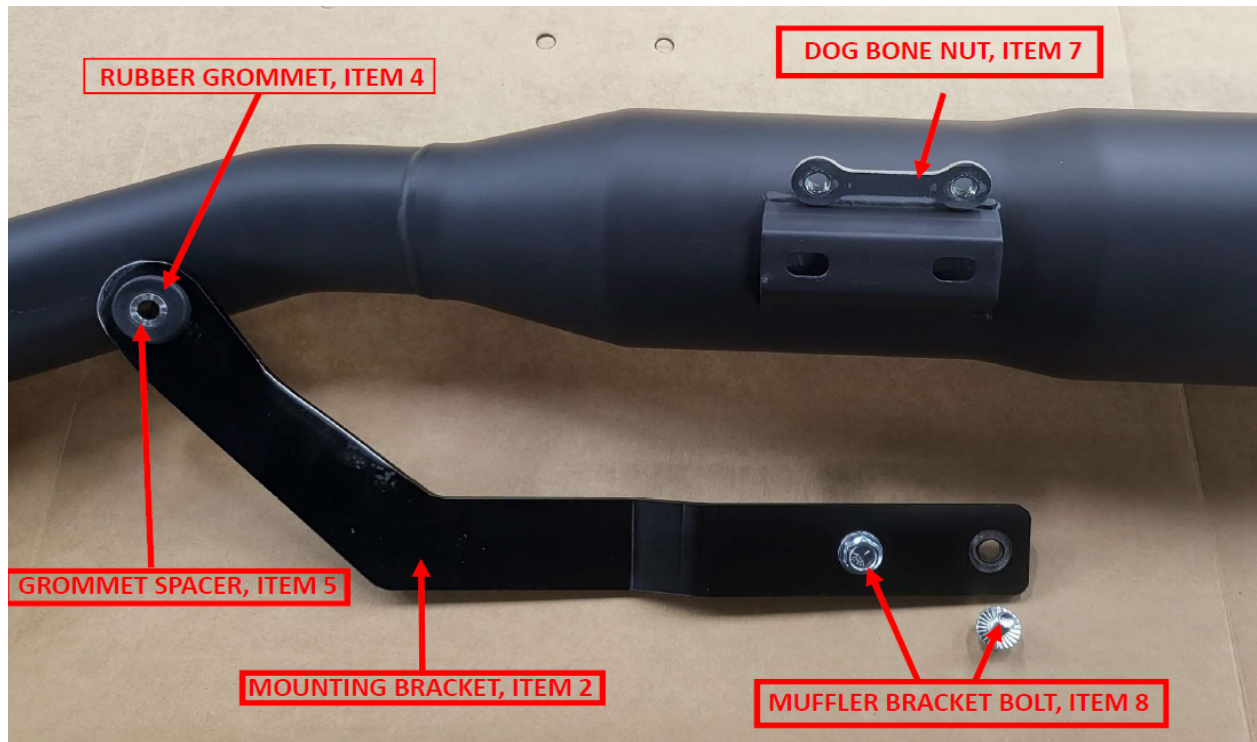

3. FIG 3: SLIP-ON INSTALLED ON OEM



4. FIG 4: CLAMP ORIENTATION

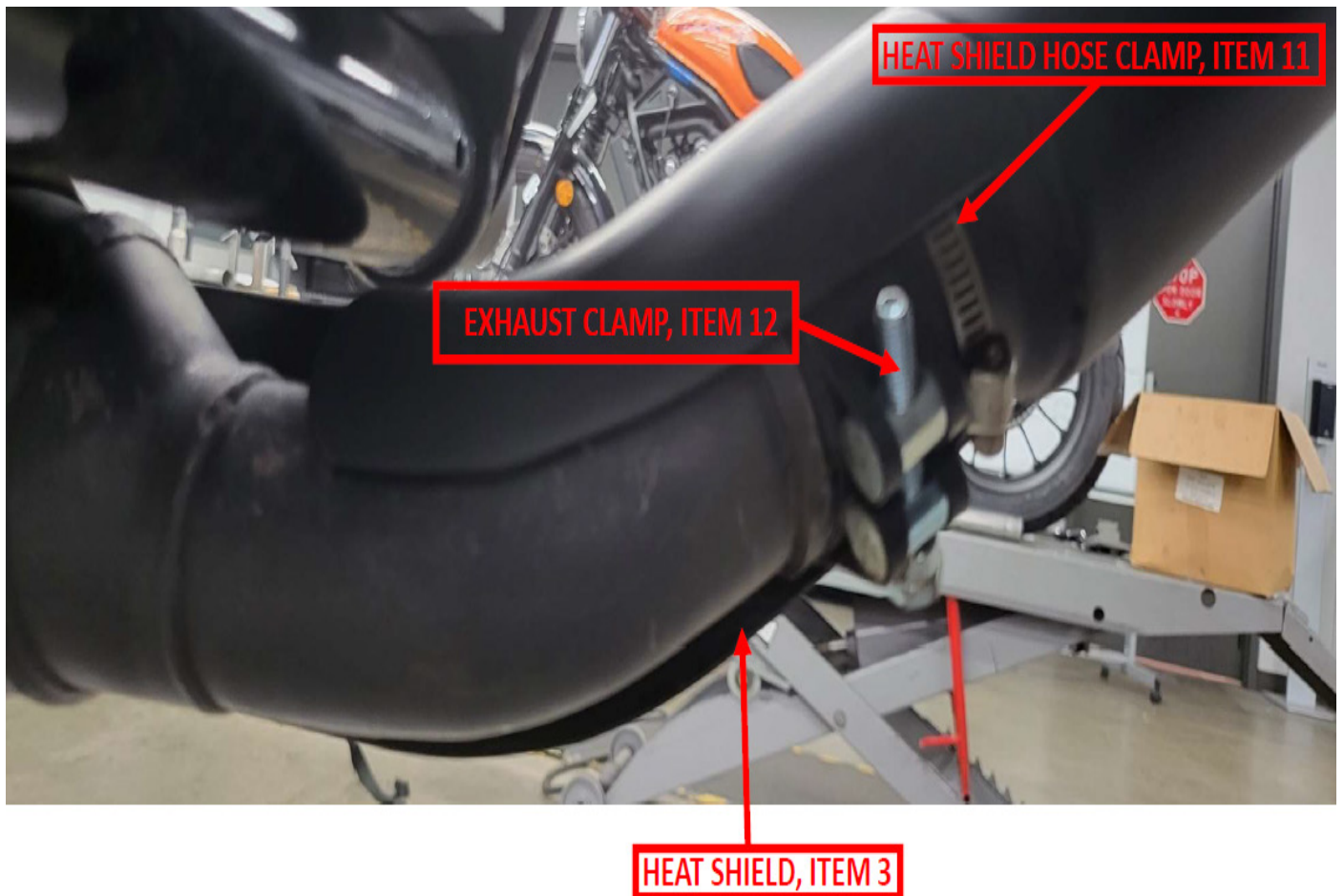

Emissions Notice:

In California, in order to meet Air Resources Board emissions requirements, certain aftermarket part applications have been identified as replacements, and others have received ARB Executive Orders. All other emissions related aftermarket parts are for competition use only. A list of replacement parts and EO parts, and corresponding [fitment](http://vanceandhines.com/California) is provided at vanceandhines.com/California.

Warranty:

All Vance & Hines products are warranted against defects in material and workmanship for a period of 90 days. This warranty does not cover discoloration or rust. This warranty shall be limited to the repair or replacement of the product, which may be proven defective under normal use. Vance & Hines will not warranty any system that has been abused, misused, improperly installed or modified.

Dealers or distributors are not authorized to make dispositions binding upon Vance & Hines. Vance & Hines will not be responsible for any labor charges incurred in removing or replacing any system under warranty. A return authorization number and a copy of the original purchase invoice must accompany all returns. Parts returned without a return authorization may be refused.]