

INSTALLATION INSTRUCTIONS: 2007-2017 HARLEY DAVIDSON SOFTAIL/HERITAGE TWIN SLASH PCX SLIP-ON'S PART# 16335

Congratulations, you have purchased the finest exhaust system available for your motorcycle. Your Vance & Hines exhaust is designed and crafted for performance, quality, and style. Please follow the instructions below, check exhaust system for missing or damaged parts and if you need any assistance please contact our technical support line (562) 921-7461.

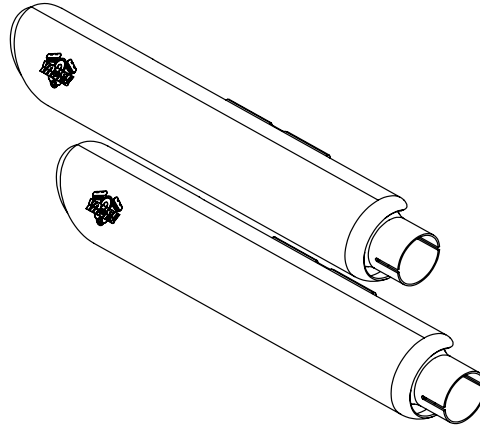

PARTS LIST

	Part No.	Description	Qty.
1	D740RC	Muffler Casing	2
2	D740HC	Chrome Heat Shield	1
3	D744HC	Chrome Heat Shield	1
4	A276HW	1.81" - 2.75" SS Hose Clamp	4
5	A240HW	5/16"-18 x 5/8" Flange Head Bolt	4
6	A195HW	Dog Bone Nut Plate	2
7	A111HW	1/4"-20 x 3/4" Hex Head Bolt	4
8	A112HW	1/4" Flat Washer	8
9	A133HW	1/4"-20 Lock Nut	4
10	458-P	Mounting Bracket	1

MUFFLER COMPONENTS

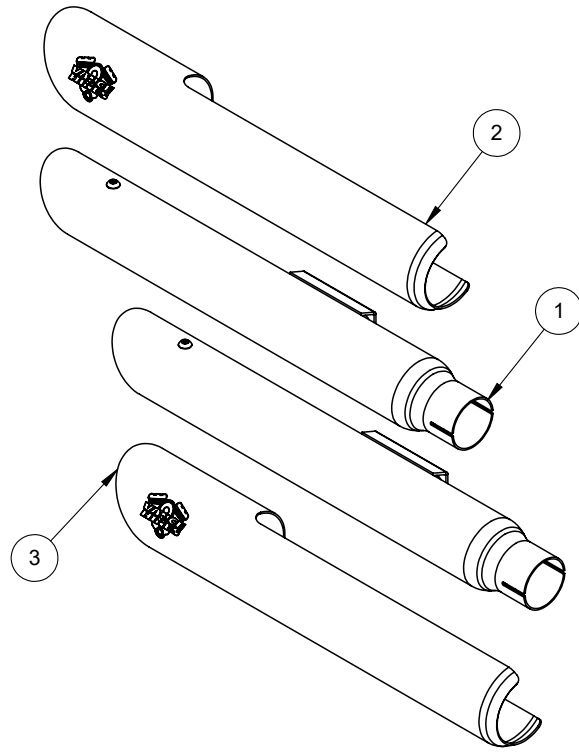

HARDWARE

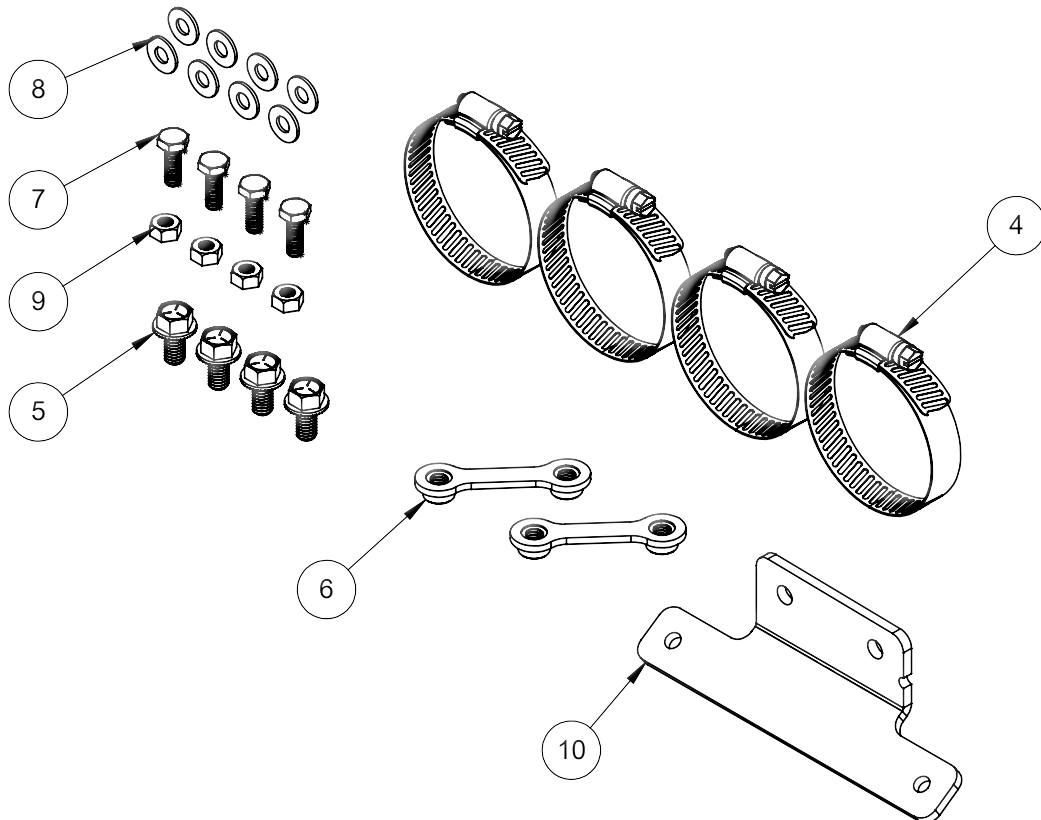

TOOLS REQUIRED

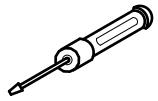

Flat Blade Screwdriver

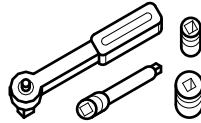

3/8" Ratchet w/ 9" extension & 3/8", 7/16", 1/2", 9/16" Sockets

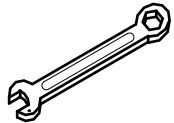

Combination Wrench: 7/16", 1/2"

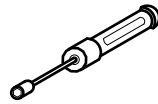

5/16" Nut Driver

STOCK EXHAUST SYSTEM REMOVAL

1. Loosen heat shield clamps on both the front and rear exhaust pipes to allow for easier access to the exhaust flange nuts.
2. Loosen the clamps holding the mufflers onto the head pipes, and the 1/4"-20 stock bolts holding them to the crossover bar.
3. Loosen, but do not remove, the exhaust flange nuts (2 for each cylinder) from each flange located at the cylinder head.
4. Remove the stock mufflers and exhaust clamps from the nose of each muffler (these will be re-used when installing the new mufflers).

VANCE & HINES EXHAUST INSTALLATION

1. Remove the muffler assemblies and heat shields from their protective packaging. Place each heat shield on a non-abrasive surface such as a towel, blanket, or carpet.
2. Carefully lay the muffler assembly into the heat shield and loosely install the hose clamps (supplied) by feeding the tail end of the clamp into the heat shield clips. Note the direction of the clamp screw heads, they must be accessible for adjustment when system is installed (Figure 1).
3. Adjust the heat shield so that the muffler body protrudes beyond the heat shield by .4 inches, and the muffler body and heat shield edges are parallel (Figure 2). Tighten band clamps.
4. Slide a nutplate inside the bracket that is welded to each of the muffler bodies. Using the supplied 5/16" x 5/8" flange head bolts, attach the mounting brackets (stamped 458-P) to the muffler bodies. Leave them loose at this time (Figure 3).
5. Slip a stock clamp over the nose of a muffler assembly. Slide the assembly onto the lower (Front) head pipe until the muffler body sits against the raised header edge. The clamp must be oriented with the nut accessible from below. Tighten the clamp enough to hold the muffler in place and allow for adjustment later.
6. Repeat step 4 with the upper muffler assembly. The clamp must be oriented with the nut being accessible from the top.

7. Using 1/4" x 3/4" hex head bolts, washers and nuts (supplied), attach the muffler brackets to the stock mounting pad. NOTE: Leave them loose at this time (Figure 4).
8. Align the mufflers, viewing from the rear of the motorcycle, the mufflers should appear aligned with each other vertically and from the side they should appear parallel with each other and the stock heat shields.
9. Holding the correct alignment, tighten the muffler clamps and support bar locking nuts. NOTE: May require assistance at the time to visually check alignment while you tighten the hardware.
10. **Be sure to verify that all hardware has been tightened before starting your motorcycle.**

EXHAUST CARE (CHROME)

1. When installing a new set of chrome pipes, make sure your hands are clean and free of oil. After installation, thoroughly clean pipes with a soft cloth and cleaning solvent that will leave no residue (chrome wax/polish, glass cleanser, alcohol, ammonia, etc...) before starting the motorcycle.
2. Follow owners manual instructions regarding use of the choke (starter enricher). If left on longer than recommended, discoloration may be accelerated.
3. Avoid long periods of idling as this can cause discoloration.
4. Intake leaks can cause the engine to run lean and overheat, this could lead to discoloration.
5. Make sure there are no exhaust leaks at the junction of the exhaust pipes and cylinder head. We recommend replacing gaskets if they are worn.

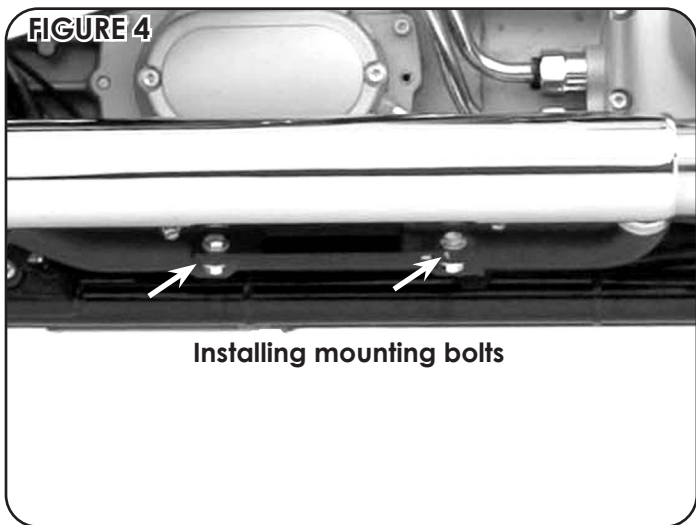
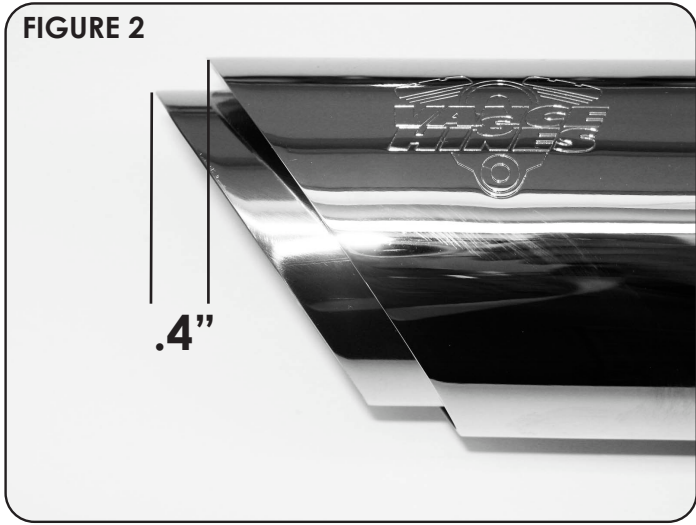
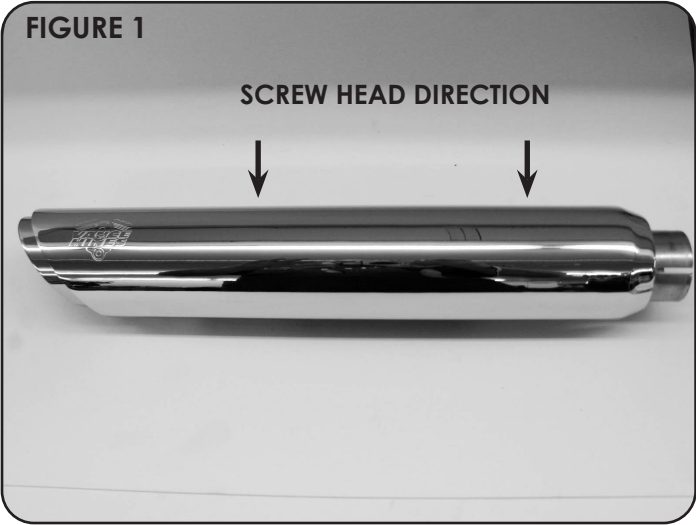

Emissions Notice:

In California, in order to meet Air Resources Board emissions requirements, certain aftermarket part applications have been identified as replacements, and others have received ARB Executive Orders. All other emissions related aftermarket parts are for competition use only. A list of replacement parts and EO parts, and corresponding fitment is provided at vanceandhines.com/california.

Warranty:

All Vance & Hines products are warranted against defects in material and workmanship for a period of 90 days. This warranty does not cover discoloration or rust. This warranty shall be limited to the repair or replacement of the product, which may be proven defective under normal use. Vance & Hines will not warranty any system that has been abused, misused, improperly installed or modified.

Dealers or distributors are not authorized to make dispositions binding upon Vance & Hines. Vance & Hines will not be responsible for any labor charges incurred in removing or replacing any system under warranty. A return authorization number and a copy of the original purchase invoice must accompany all returns. Parts returned without a return authorization may be refused.

13861 ROSECRANS AVENUE / SANTA FE SPRINGS, CA 90670
SALES: (562) 921-5388
TECHNICAL: (562) 926-5291
FAX: (562) 802-0110

vanceandhines
.com