

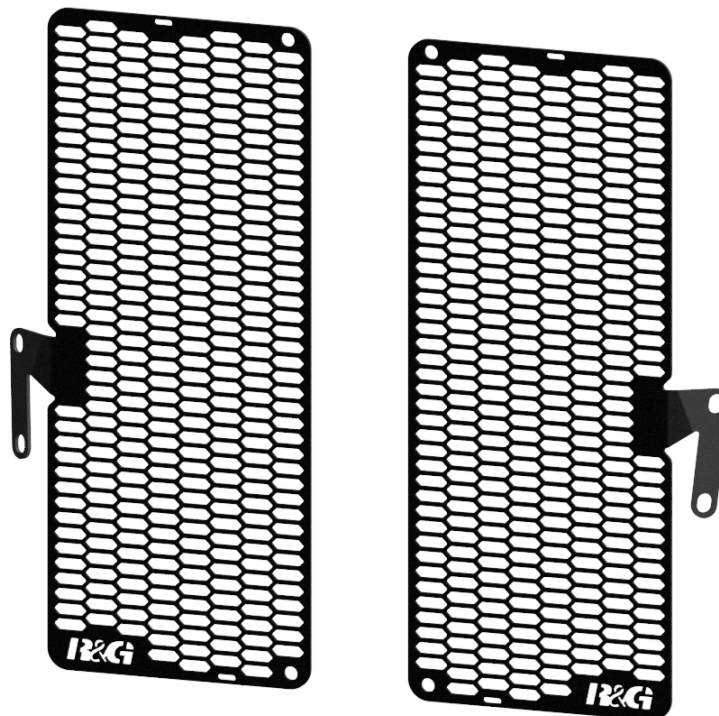

FITTING INSTRUCTIONS FOR RAD0307PRO
RADIATOR GUARD PAIR



THIS KIT CONTAINS THE ITEMS PICTURED AND LABELLED OVER PAGE.

SOME PARTS MAY BE SHOWN FOR CLARITY OF INSTRUCTIONS ONLY.

DO NOT PROCEED UNTIL YOU ARE SURE ALL PARTS ARE PRESENT.

PLEASE READ ALL INSTRUCTIONS BEFORE PROCEEDING.

**IF IN ANY DOUBT WHEN FITTING OUR PRODUCTS, CONSULT ONE OF OUR DEALERS
OR HAVE FITTED BY A QUALIFIED TECHNICIAN.**

PLEASE NOTE THAT THE WAY THE KIT IS PACKED DOES NOT NECESSARILY REPRESENT THE WAY OF
MOUNTING TO THE BIKE.

IN THE EVENT OF RUBBER WASHERS BEING USED TO HOLD COMPONENTS ONTO BOLTS,
THESE RUBBER WASHERS CAN BE THROWN AWAY.

DIGITAL COPIES OF THESE INSTRUCTIONS ARE AVAILABLE FROM:

WWW.RG-RACING.COM



<u>TOOLS REQUIRED</u>	<u>GENERAL TORQUE SETTINGS</u>
<ul style="list-style-type: none"> • SET OF ALLEN KEYS TO INCLUDE 3mm. <ul style="list-style-type: none"> • NEEDLE NOSE PLIERS. • CABLE CUTTERS OR SCISSORS. 	<p>M4 BOLT = 8Nm M5 BOLT = 12Nm M6 BOLT = 15Nm M8 BOLT = 20Nm M10 BOLT = 40Nm M12 BOLT = 40Nm</p>

LEGEND

ITEM NO.	DESCRIPTION	QTY
ITEM 1	RAD0307PRO LHS RADIATOR GUARD	1
ITEM 2	RAD0307PRO RHS RADIATOR GUARD	1
ITEM 3	M5x10mm BUTTON HEAD BOLT	4
ITEM 4	M5x10MM O/D WASHER	4
ITEM 5	CT130 RADIATOR CABLE TIE (4-PACK)	2
ITEM 6	RUBBER BUNGS (NOT SHOWN)	4

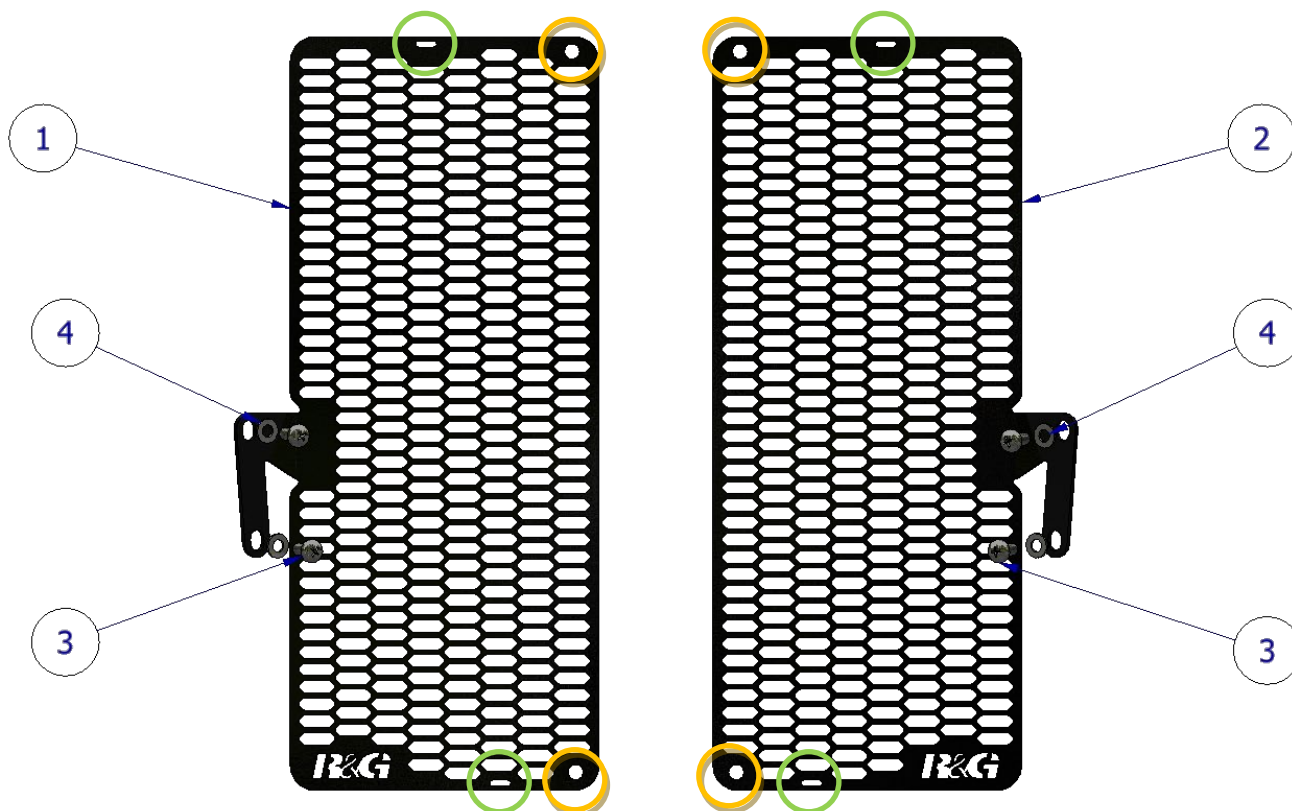

R&G Racing

Unit 1, Shelley's Lane, East Worldham, Alton, Hampshire, GU34 3AQ

Tel: +44 (0)1420 89007 Fax: +44 (0)1420 87301 www.rg-racing.com Email: info@rg-racing.com

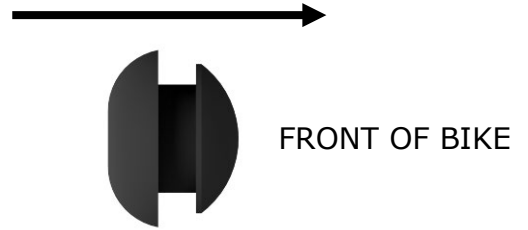
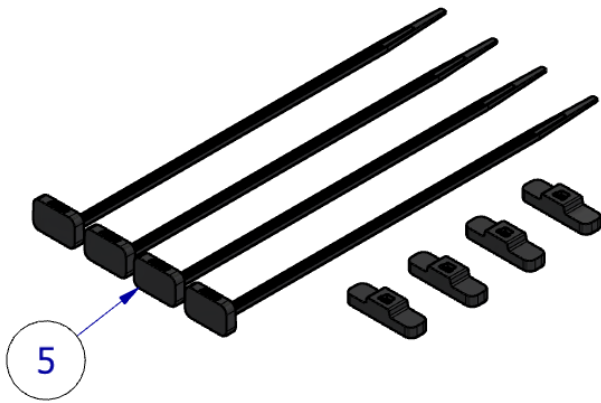

FITTING PICTURES

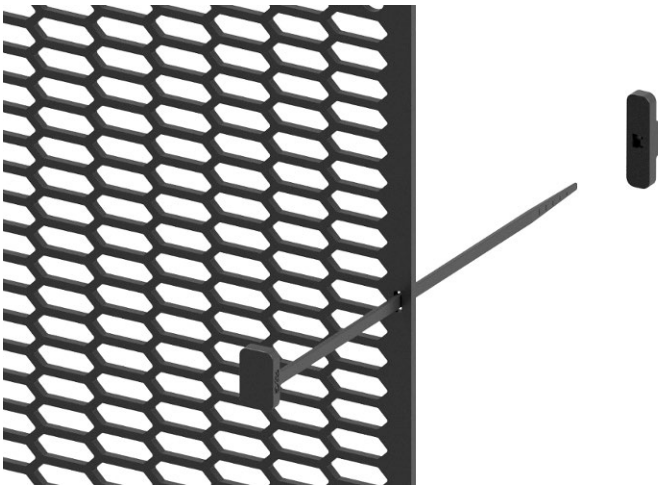

Picture 1

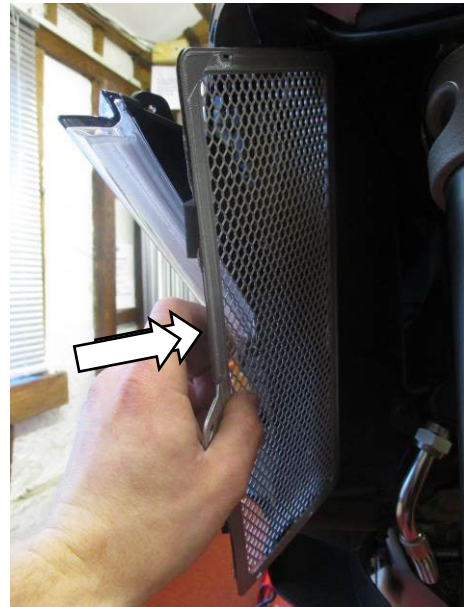

Picture 2

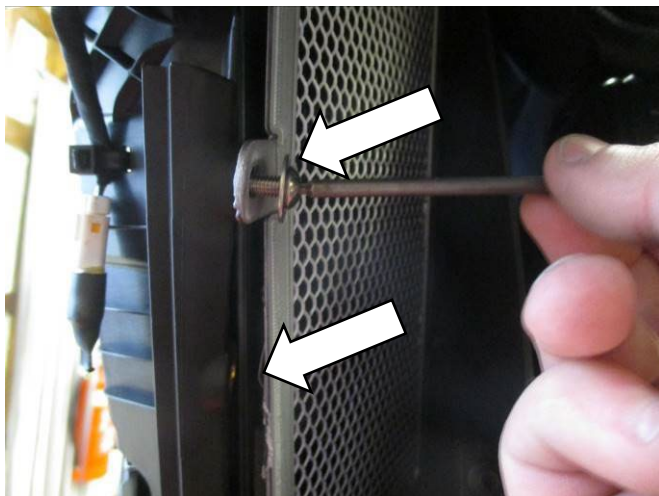

Picture 3



Picture 4



FITTING INSTRUCTIONS

- To begin, press the rubber bungs (item 6) provided into the holes circled in yellow in the assembly diagram, in the correct orientation.
- Slide LHS the radiator guard (item 1) into position ensuring the two mounting holes line up correctly and the guard fits neatly over the radiator, as shown in **picture 2**.
- Referring to the Assembly diagram on page 2, Use two M5 button head bolts (item 3) and M5 washers (item 4) to secure the radiator guard into place as shown in **picture 3**, do not fully tighten the bolts at this stage.
- Using two of the special radiator guard cable ties (Item 5), thread one cable tie through the upper and lower slots on the radiator guard (circled in green on the assembly diagram), ensuring the tail goes through the outer matrix hole and to the back of the radiator matrix as shown in **picture 4**. Note, ensure the tie does not interfere with the fans on the rear of the radiator.
- Take one of the cable tie locking pieces and carefully attach top the back of the cable tie tail and slide up until it firmly holds the radiator in place. Do not overtighten as damage to the fins can occur.
- Once secure, trim the excess cable tie from the back of the radiator using a pair of snips.
- With cable ties now in place, fully tighten the securing bolts to the recommended torque.
- Repeat the process for the RHS radiator guard (item 2).
- Check all components are secure and all bolts are tight before riding.

See more R&G products for your Motorcycle in the link below:

[R&G Racing | Cleaning/Lubrication - Gleam range for All Vehicles \(rg-racing.com\)](http://www.rg-racing.com)

ISSUE 2 - 11/04/2023 (MH)

CONSUMER NOTICE

The catalogue description and any exhibition of samples are only broad indications of the Products and R&G may make design changes which do not diminish their performance or visual appeal and supplying them in such state shall conform to the order. The Buyer acknowledges no representation or warranty (other than as to title) has been given or will apply to the Products other than those in R&G's order or confirmation and the Buyer confirms it has chosen the Products as being of merchantable quality and suitable for its particular purposes. Where R&G fits the Products or undertakes other services it shall exercise reasonable skill and care and rectify any fault free of charge unless the workmanship has been disturbed. The Buyer is responsible for ensuring that the warranty on the motorcycle is not affected by the fitting of the Products. On return of any defective Products R&G shall at its option either supply a replacement or refund the purchase money but shall not be liable if the Products have been modified or used or maintained otherwise than in accordance with R&G's or manufacturer's instructions and good engineering practice or if the defect arises from accident or neglect. Other than identified above and subject to R&G not limiting its liability for causing death and personal injury, it shall not be liable for indirect or consequential loss and otherwise its liability shall be limited to the amounts paid by the Buyer for the Products or the fitting or service concerned. These terms do not affect the Buyer's statutory rights.

R&G RACING RETURNS POLICY (NON-FAULTY GOODS)

Returns must be pre-authorized (if not pre-authorized the return will be rejected). Goods may only be returned direct to us if they were purchased direct from us (customer must prove if necessary). Otherwise to be returned to original vendor. Goods must be in re-sellable condition, in the opinion of R&G Racing. All returns are subject to a 25% restocking and handling fee (25% of the gross value exc. P&P - at the prevailing price at time of purchase). The customer must pay any and all carriage charges. No returns of discontinued products, unless within 14 days of purchase. This policy does not affect your statutory rights and does not refer to faulty goods.

R&G Racing

Unit 1, Shelley's Lane, East Worldham, Alton, Hampshire, GU34 3AQ

Tel: +44 (0)1420 89007 Fax: +44 (0)1420 87301 www.rg-racing.com Email: info@rg-racing.com



NOTICE DE MONTAGE POUR RAD0307PRO
PAIRE DE PROTECTIONS RADIATEUR

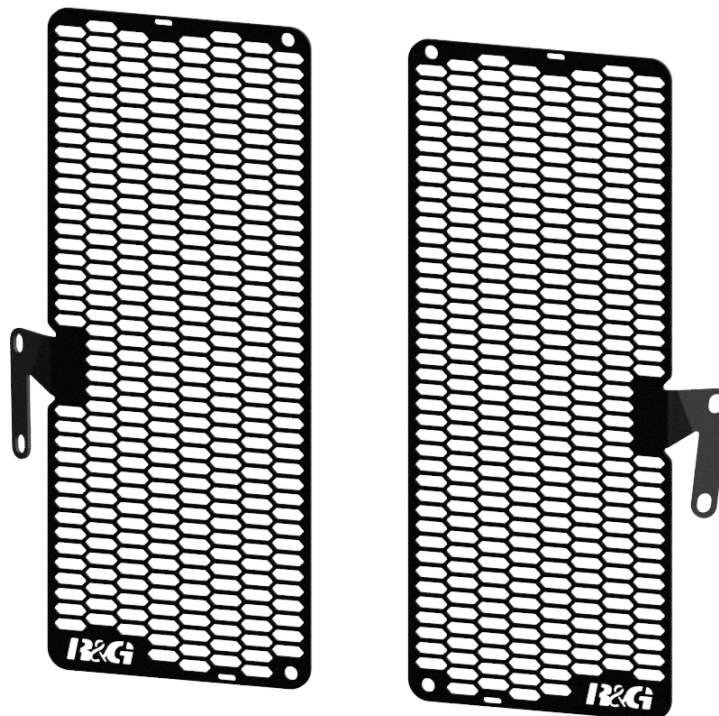

CE KIT CONTIENT LES ARTICLES ILLUSTRÉS ET ÉTIQUETES SUR LA PAGE.

CERTAINES PARTIES PEUVENT ÊTRE PRÉSENTES UNIQUEMENT POUR LA CLARTÉ DES INSTRUCTIONS.

NE PAS PROCÉDER AU MONTAGE TANT QUE VOUS N'ÊTES PAS SÛR QUE TOUTES LES PIÈCES SOIENT PRÉSENTES.

VEUILLEZ LIRE TOUTES LES INSTRUCTIONS AVANT DE CONTINUER.

EN CAS DE DOUTE LORS DU MONTAGE DE NOS PRODUITS, CONSULTEZ UN DE NOS REVENEURS OU FAITES APPEL À UN TECHNICIEN QUALIFIÉ.

VEUILLEZ NOTER QUE LA FAÇON DONT LE KIT EST EMBALLÉ NE REPRÉSENTE PAS NECESSAIREMENT LA MANIÈRE DE LE MONTER SUR LA MOTO.

SI DES RONDELLES EN CAOUTCHOUC SONT UTILISÉES POUR MAINTENIR LES COMPOSANTS SUR LES BOULONS, ELLES PEUVENT ÊTRE JETÉES.

NOTICE DISPONIBLE AU TÉLÉCHARGEMENT SUR :

WWW.RG-RACING.COM

R&G Racing

Unit 1, Shelley's Lane, East Worldham, Alton, Hampshire, GU34 3AQ

Tel: +44 (0)1420 89007 Fax: +44 (0)1420 87301 www.rg-racing.com Email: info@rg-racing.com



OUTILS REQUIS	VALEURS DE SERRAGE
<ul style="list-style-type: none"> • CLÉS ALLEN 3mm. • • PINCE À BEC POINTU. • COUPE CÂBLE / CISEAUX 	<p>M4 BOULON = 8Nm</p> <p>M5 BOULON = 12Nm</p> <p>M6 BOULON = 15Nm</p> <p>M8 BOULON = 20Nm</p> <p>M10 BOULON = 40Nm</p> <p>M12 BOULON = 40Nm</p>

LÉGENDE

ARTICLE NO.	DESCRIPTION	QTÉ
ARTICLE 1	RAD0307PRO PROTECTION RADIATEUR GAUCHE	1
ARTICLE 2	RAD0307PRO PROTECTION RADIATEUR DROITE	1
ARTICLE 3	M5x10mm BOULON	4
ARTICLE 4	M5x10MM RONDELLE	4
ARTICLE 5	CT130 COLLIER DE SERRAGE RADIATEUR (4-PACK)	2
ARTICLE 6	OEILLETS EN CAOUTCHOUC (NON REPRÉSENTÉS)	4

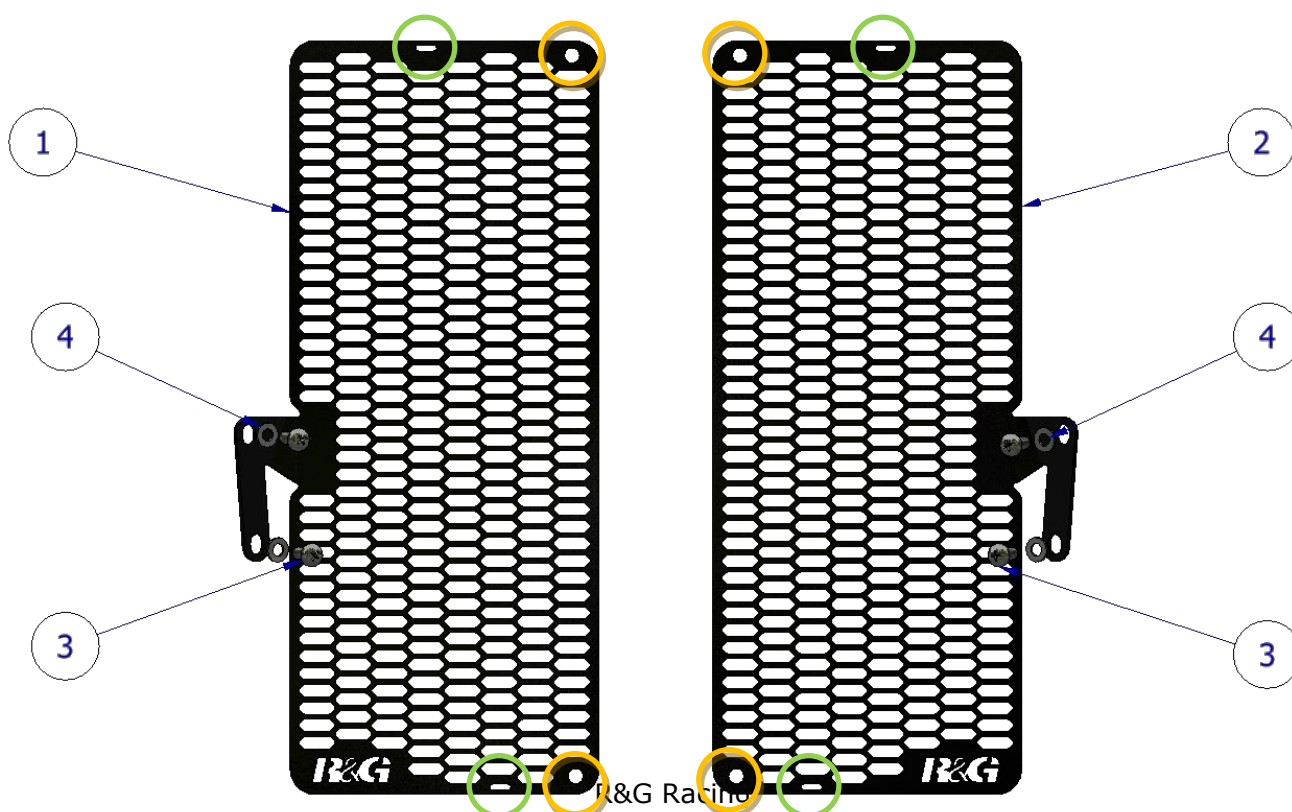

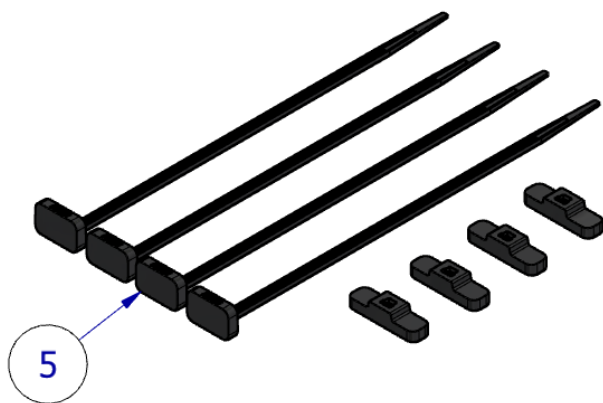

FRONT OF BIKE

PHOTOS DE MONTAGE

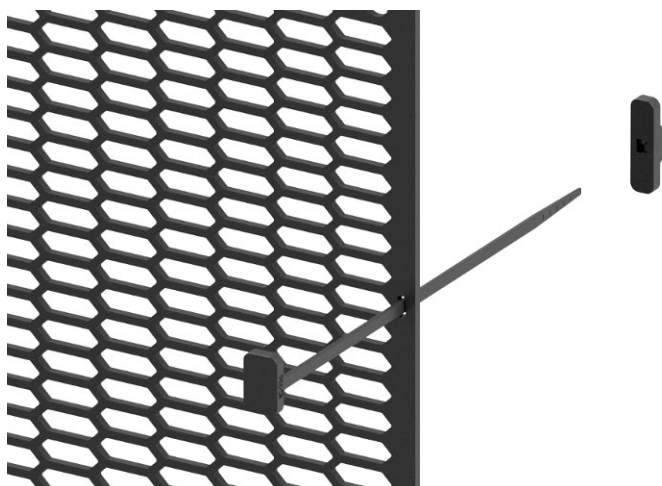

Photo 1

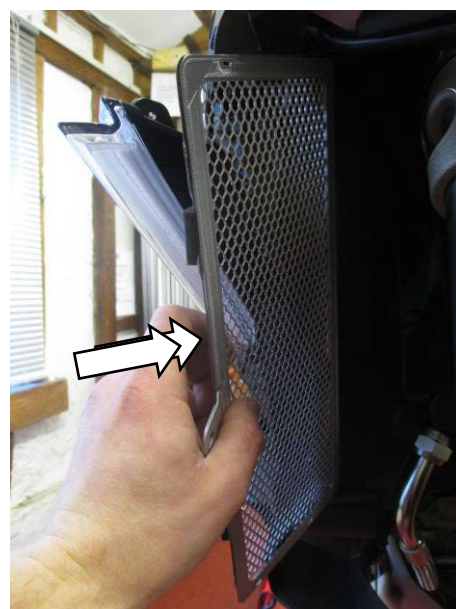

Photo 2

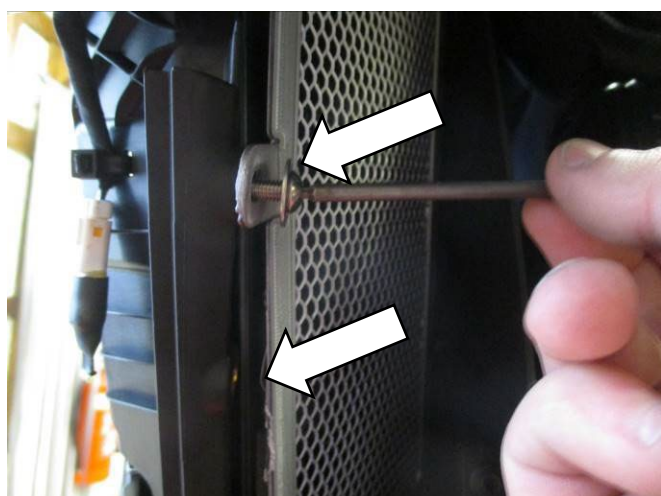

Photo 3



Photo 4



NOTICE DE MONTAGE

- Pour commencer, enfoncez les bouchons en caoutchouc (article 6) fournis dans les trous entourés en jaune sur le schéma de montage, dans le bon sens.
- Faites glisser le protège-radiateur gauche (article 1) en position en vous assurant que les deux trous de montage soient correctement alignés et que le protège-radiateur s'adapte parfaitement sur le radiateur, comme indiqué sur la photo 2.
- En vous référant au schéma de montage à la page 2, utilisez deux boulons à tête ronde M5 (article 3) et des rondelles M5 (article 4) pour fixer la protection du radiateur en place comme indiqué sur la photo 3, ne serrez pas complètement les boulons à ce stade.
- À l'aide de deux serre-câbles spéciaux pour protège-radiateur (article 4), enfitez un serre-câble dans les fentes supérieure et inférieure du protège-radiateur (entourées en vert sur le schéma de montage), en veillant à ce que la queue passe par le trou extérieur de la matrice et l'arrière de la matrice du radiateur comme indiqué sur la photo 4. Veillez à ce que l'attache n'interfère pas avec les ventilateurs à l'arrière du radiateur.
- Prenez l'une des pièces de verrouillage du serre-câble et fixez-la soigneusement à l'arrière de la queue du serre-câble et faites-la glisser jusqu'à ce qu'elle maintienne fermement le radiateur en place. Ne serrez pas trop car cela pourrait endommager les ailettes.
- Une fois fixé, coupez l'excédent d'attache de câble à l'arrière du radiateur à l'aide d'une paire de ciseaux.
- Une fois les serre-câbles en place, serrez complètement les boulons de fixation au couple recommandé.
- Répétez le processus pour le protège-radiateur côté droit (article 2).
- Vérifiez que tous les composants soient sécurisés et que tous les boulons soient bien serrés avant de rouler.

Voir plus de produits R&G pour votre moto via ce lien :
[R&G Racing | Cleaning/Lubrication - Gleam range for All Vehicles \(rg-racing.com\)](https://www.rg-racing.com)

ISSUE 2 - 11/04/2023 (MH)

CONSUMER NOTICE

The catalogue description and any exhibition of samples are only broad indications of the Products and R&G may make design changes which do not diminish their performance or visual appeal and supplying them in such state shall conform to the order. The Buyer acknowledges no representation or warranty (other than as to title) has been given or will apply to the Products other than those in R&G's order or confirmation and the Buyer confirms it has chosen the Products as being of merchantable quality and suitable for its particular purposes. Where R&G fits the Products or undertakes other services it shall exercise reasonable skill and care and rectify any fault free of charge unless the workmanship has been disturbed. The Buyer is responsible for ensuring that the warranty on the motorcycle is not affected by the fitting of the Products. On return of any defective Products R&G shall at its option either supply a replacement or refund the purchase money but shall not be liable if the Products have been modified or used or maintained otherwise than in accordance with R&G's or manufacturer's instructions and good engineering practice or if the defect arises from accident or neglect. Other than identified above and subject to R&G not limiting its liability for causing death and personal injury, it shall not be liable for indirect or consequential loss and otherwise its liability shall be limited to the amounts paid by the Buyer for the Products or the fitting or service concerned. These terms do not affect the Buyer's statutory rights.

R&G RACING RETURNS POLICY (NON-FAULTY GOODS)

Returns must be pre-authorized (if not pre-authorized the return will be rejected). Goods may only be returned direct to us if they were purchased direct from us (customer must prove if necessary). Otherwise to be returned to original vendor. Goods must be in re-sellable condition, in the opinion of R&G Racing. All returns are subject to a 25% restocking and handling fee (25% of the gross value exc. P&P - at the prevailing price at time of purchase). The customer must pay any and all carriage charges. No returns of discontinued products, unless within 14 days of purchase. This policy does not affect your statutory rights and does not refer to faulty goods.

R&G Racing

Unit 1, Shelley's Lane, East Worldham, Alton, Hampshire, GU34 3AQ

Tel: +44 (0)1420 89007 Fax: +44 (0)1420 87301 www.rg-racing.com Email: info@rg-racing.com



MONTAGEANLEITUNG FÜR RAD0307PRO
KÜHLERSCHUTZ - PAAR

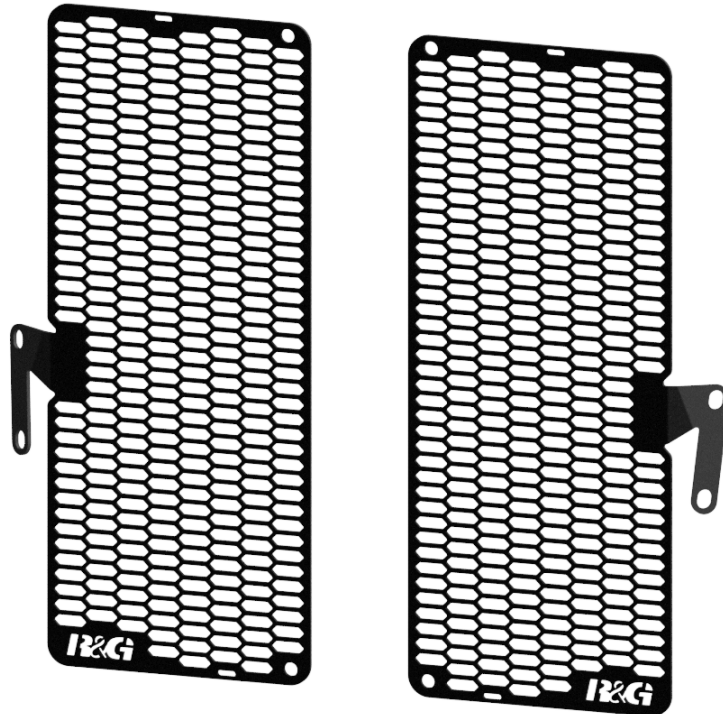

ALLE KIT-TEILE SIND AUF DEN NACHFOLGENDEN SEITEN ABGEBILDET UND GEKENNZEICHNET.

DIE ABGEBILDETEN TEILE DIENEN LEDIGLICH ZUR ERKLÄRUNG.

ÜBERPRÜFEN SIE ZUERST, DASS ALLE TEILE VORHANDEN SIND.

LESEN SIE DIE MONTAGEANLEITUNG KOMPLETT DURCH, BEVOR SIE ANFANGEN.

WENN SIE BEI DER MONTAGE DIESES PRODUKTES UNSICHER SIND, BITTE EINEN UNSERER HÄNDLER KONTAKTIEREN ODER DAS KIT VON EINEM QUALIFIZIERTEN ZWEIRAD-MECHANIKER MONTIEREN LASSEN.

DIE VERPACKUNG DER TEILE STELLT NICHT DIE REIHENFOLGE DER MONTAGE DAR.

HINWEIS FÜR KITS MIT PLASTIKUNTERLEGSscheIBEN AN DEN SCHRAUBEN –
DIESE PLASTIK-UNTERLEGSscheIBEN WERDEN NICHT FÜR DEN EINBAU BENÖTIGT.

EINE DIGITALE VERSION DIESER MONTAGEANLEITUNG KANN AUF FOLGENDER SEITE HERUNTERGELADEN WERDEN:

WWW.RG-RACING.COM

R&G Racing

Unit 1, Shelley's Lane, East Worldham, Alton, Hampshire, GU34 3AQ

Tel: +44 (0)1420 89007 Fax: +44 (0)1420 87301 www.rg-racing.com Email: info@rg-racing.com

**SIE BENÖTIGEN FOLGENDES WERKZEUG**

- SATZ INBUSSCHLÜSSEL INKL. 3mm
 - SPITZZANGE
- SEITENSCHNEIDER ODER SCHERE

ALLGEM. ANZUGSDREHMOMENT:

- M4 SCHRAUBE = 8Nm
- M5 SCHRAUBE = 12Nm
- M6 SCHRAUBE = 15Nm
- M8 SCHRAUBE = 20Nm
- M10 SCHRAUBE = 40Nm
- M12 SCHRAUBE = 40Nm

LIEFERUMFANG

ARTIKEL NR.	BESCHREIBUNG	MENGE
ARTIKEL 1	RAD0307PRO KÜHLERSCHUTZ LINKE SEITE	1
ARTIKEL 2	RAD0307PRO KÜHLERSCHUTZ RECHTE SEITE	1
ARTIKEL 3	M5x10mm INBUSSCHRAUBE	4
ARTIKEL 4	M5x10MM O/D UNTERLEGSCHIEBE	4
ARTIKEL 5	CT130 KABELBINDER FÜR KÜHLERSCHUTZ (4er-PACK)	2
ARTIKEL 6	GUMMISTOPFEN (NICHT ABGEBILDET)	4

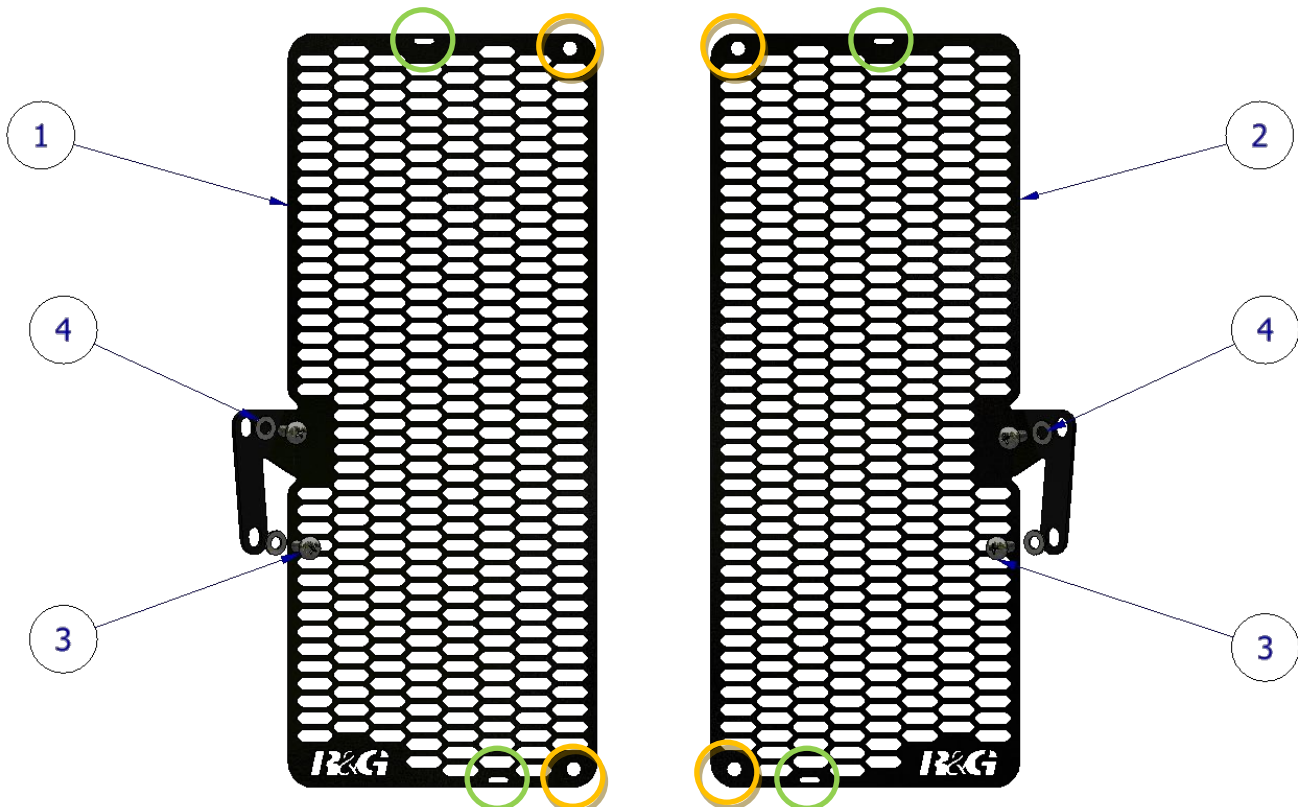

R&G Racing

Unit 1, Shelley's Lane, East Worldham, Alton, Hampshire, GU34 3AQ

Tel: +44 (0)1420 89007 Fax: +44 (0)1420 87301 www.rg-racing.com Email: info@rg-racing.com

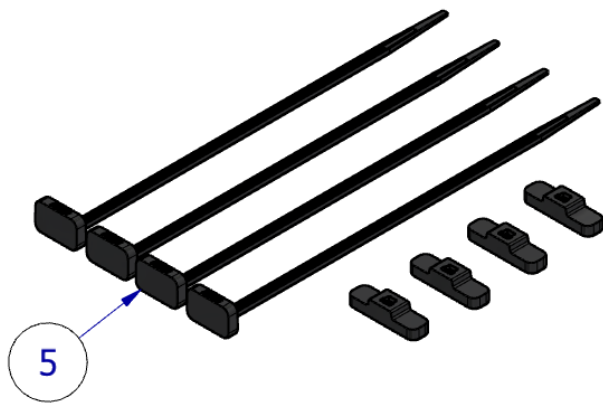

MOTORRAD VORNE

MONTAGE -ABBILDUNGEN



Abbildung 1



Abbildung 2

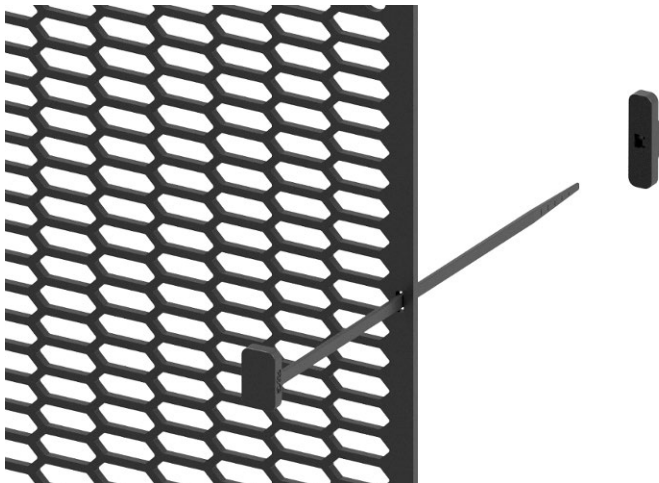

Abbildung 3

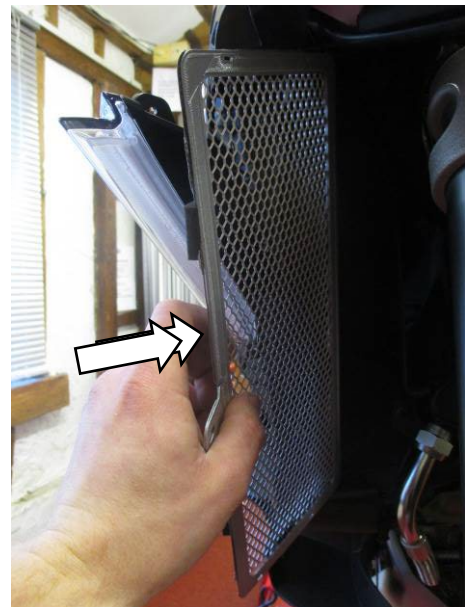

Abbildung 4

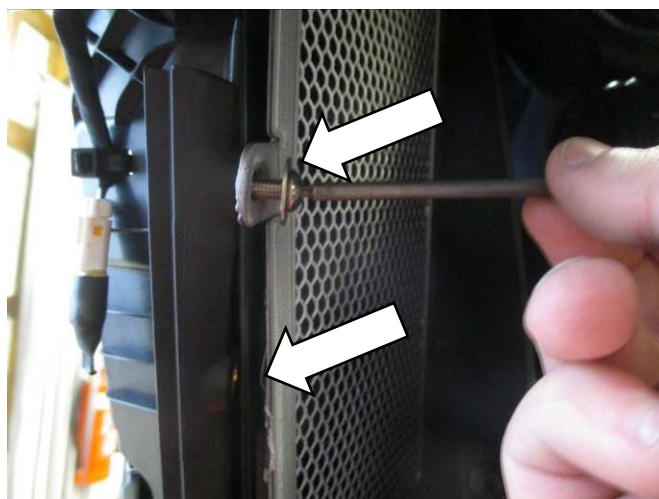

MONTAGEANLEITUNG

- Zuerst die Gummistopfen vom Kit (Artikel 6) in die Öffnungen im Kühlerschutz einsetzen, die in der Zeichnung Zusammenbau mit gelben Kreisen markiert sind.
- Den R&G Kühlerschutz für die linke Seite (Artikel 1) in Position bringen und sicherstellen, dass die zwei Montageöffnungen korrekt ausgerichtet sind und der Kühlerschutz auf den Kühler passt wie in **Abbildung 2** abgebildet.
- Entsprechend der Zeichnung Zusammenbau auf Seite 2, den Kühlerschutz mit die zwei M5 Inbusschrauben (Artikel 3) und M5 Unterlegscheiben (Artikel 4) in der in **Abbildung 3** gezeigten Position fixieren – die Schrauben zu diesem Zeitpunkt nicht komplett festziehen.
- Nehmen Sie zwei der speziellen Kabelbinder für den Kühlerschutz (Artikel 4) und fädeln Sie einen durch die obere und untere Schlitzöffnung im Kühlerschutz (diese sind mit grünen Kreisen in der Zeichnung Zusammenbau gekennzeichnet). Stellen Sie sicher, dass das Kabelband durch die äußere Matrixöffnung zum Kühlermatrix nach hinten geführt wird wie in **Abbildung 4** abgebildet. Hinweis: Achten Sie darauf, dass der Kabelbinder die Lüfter an der Rückseite des Kühlers nicht beeinträchtigt
- Nehmen Sie ein Kabelbinder-Verschlussstück und montieren Sie das vorsichtig an der Rückseite des Kabelbands. Stellen Sie sicher, dass das Verzahnungsteil in die Verzahnung des Kabelbinders greift und dann hochschieben, bis er den Kühler in Position fixiert. Nicht zu festziehen!
- Wenn alles sicher fixiert ist, das überschüssige Kabelband mit einem Seitenscheider oder einer Schere abschneiden.
- Wenn die Kabelbinder in Position sind, die Befestigungsschrauben mit dem empfohlenen Anzugsdrehmoment festziehen.
- Wiederholen Sie diese Schritte wieder, um den Kühlerschutz für die rechte Seite (Artikel 2) zu montieren.
- Überprüfen Sie, dass alle Komponente sicher befestigt und alle Schrauben festgezogen sind, bevor Sie mit dem Motorrad fahren.

Klicken Sie hier, um weitere R&G Produkte für Ihr Motorrad zu finden:

[R&G Racing | Cleaning/Lubrication - Gleam range for All Vehicles \(rg-racing.com\)](https://www.rg-racing.com)

AUSGABE 2 – 11/04/2023 (MH)

CONSUMER NOTICE

The catalogue description and any exhibition of samples are only broad indications of the Products and R&G may make design changes which do not diminish their performance or visual appeal and supplying them in such state shall conform to the order. The Buyer acknowledges no representation or warranty (other than as to title) has been given or will apply to the Products other than those in R&G's order or confirmation and the Buyer confirms it has chosen the Products as being of merchantable quality and suitable for its particular purposes. Where R&G fits the Products or undertakes other services it shall exercise reasonable skill and care and rectify any fault free of charge unless the workmanship has been disturbed. The Buyer is responsible for ensuring that the warranty on the motorcycle is not affected by the fitting of the Products. On return of any defective Products R&G shall at its option either supply a replacement or refund the purchase money but shall not be liable if the Products have been modified or used or maintained otherwise than in accordance with R&G's or manufacturer's instructions and good engineering practice or if the defect arises from accident or neglect. Other than identified above and subject to R&G not limiting its liability for causing death and personal injury, it shall not be liable for indirect or consequential loss and otherwise its liability shall be limited to the amounts paid by the Buyer for the Products or the fitting or service concerned. These terms do not affect the Buyer's statutory rights.

R&G RACING RETURNS POLICY (NON-FAULTY GOODS)

Returns must be pre-authorized (if not pre-authorized the return will be rejected). Goods may only be returned direct to us if they were purchased direct from us (customer must prove if necessary). Otherwise to be returned to original vendor. Goods must be in re-sellable condition, in the opinion of R&G Racing. All returns are subject to a 25% restocking and handling fee (25% of the gross value exc. P&P – at the prevailing price at time of purchase). The customer must pay any and all carriage charges. No returns of discontinued products, unless within 14 days of purchase. This policy does not affect your statutory rights and does not refer to faulty goods.

R&G Racing

Unit 1, Shelley's Lane, East Worldham, Alton, Hampshire, GU34 3AQ

Tel: +44 (0)1420 89007 Fax: +44 (0)1420 87301 www.rg-racing.com Email: info@rg-racing.com