

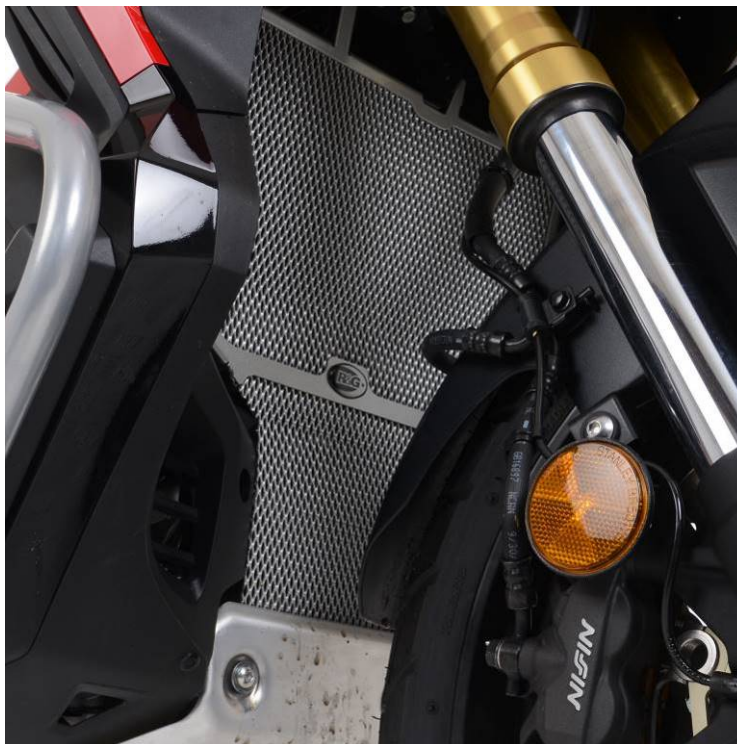

**FITTING INSTRUCTIONS FOR RAD0274**  
**RADIATOR GUARD**  
**HONDA X-ADV 2021-**



**THIS KIT CONTAINS THE ITEMS PICTURED AND LABELLED OVER PAGE.**

SOME PARTS MAY BE SHOWN FOR CLARITY OF INSTRUCTIONS ONLY.

DO NOT PROCEED UNTIL YOU ARE SURE ALL PARTS ARE PRESENT.

**PLEASE READ ALL INSTRUCTIONS BEFORE PROCEEDING.**

**IF IN ANY DOUBT WHEN FITTING OUR PRODUCTS, CONSULT ONE OF OUR DEALERS  
OR HAVE FITTED BY A QUALIFIED TECHNICIAN.**

PLEASE NOTE THAT THE WAY THE KIT IS PACKED DOES NOT NECESSARILY REPRESENT THE WAY OF  
MOUNTING TO THE BIKE.

IN THE EVENT OF RUBBER WASHERS BEING USED TO HOLD COMPONENTS ONTO BOLTS,  
THESE RUBBER WASHERS CAN BE THROWN AWAY.

**DIGITAL COPIES OF THESE INSTRUCTIONS ARE AVAILABLE FROM:**

[WWW.RG-RACING.COM](http://WWW.RG-RACING.COM)

R&G Racing  
Unit 1, Shelley's Lane, East Worldham, Alton, Hampshire, GU34 3AQ  
Tel: +44 (0)1420 89007 Fax: +44 (0)1420 87301 [www.rg-racing.com](http://www.rg-racing.com) Email: [info@rg-racing.com](mailto:info@rg-racing.com)



<u>TOOLS REQUIRED</u>	<u>GENERAL TORQUE SETTINGS</u>
<ul style="list-style-type: none"> <li>• SET OF ALLEN KEYS                             <ul style="list-style-type: none"> <li>• 10MM SPANNER</li> </ul> </li> <li>• CABLE CUTTERS OR SCISSORS.</li> </ul>	<p>M4 BOLT = 8Nm                      M5 BOLT = 12Nm                      M6 BOLT = 15Nm                      M8 BOLT = 20Nm                      M10 BOLT = 40Nm                      M12 BOLT = 40Nm</p>

**LEGEND**

ITEM NO.	DESCRIPTION	QTY
ITEM 1	RAD0274 RADIATOR GUARD	1
ITEM 2	M5x25mm BUTTON HEAD BOLT	2
ITEM 3	M5x20MM O/D WASHER	2
ITEM 4	100mm SELF-ADHESIVE FOAM	3
ITEM 5	2.5MM CABLE TIE	1

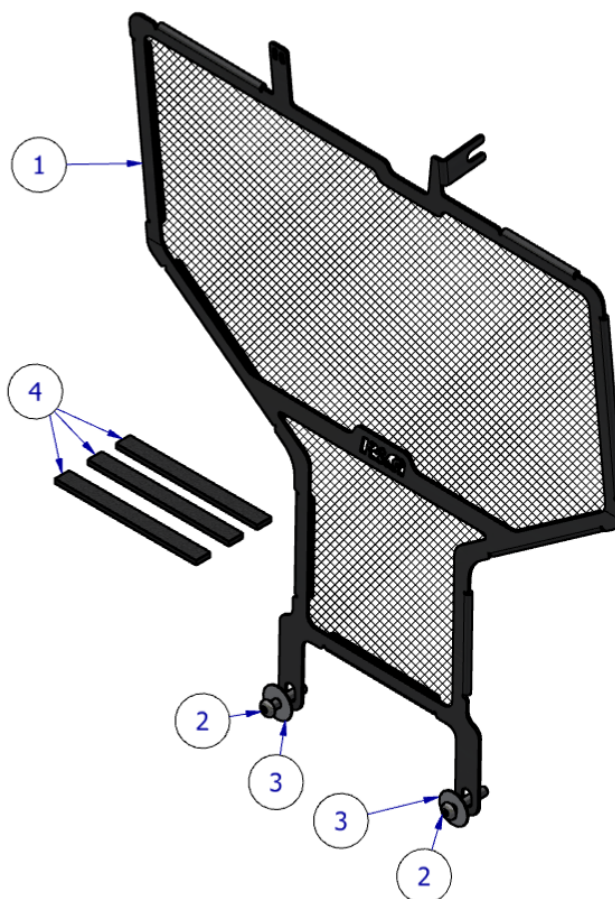



**FITTING PICTURES**

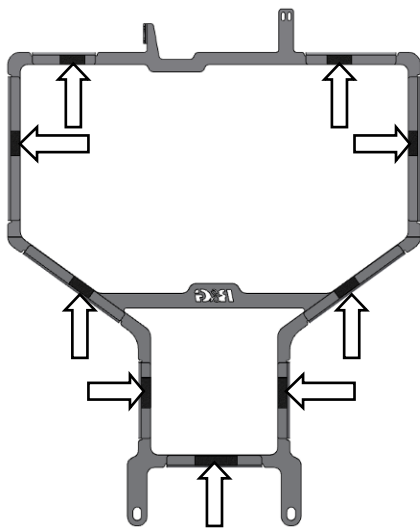

Picture 1

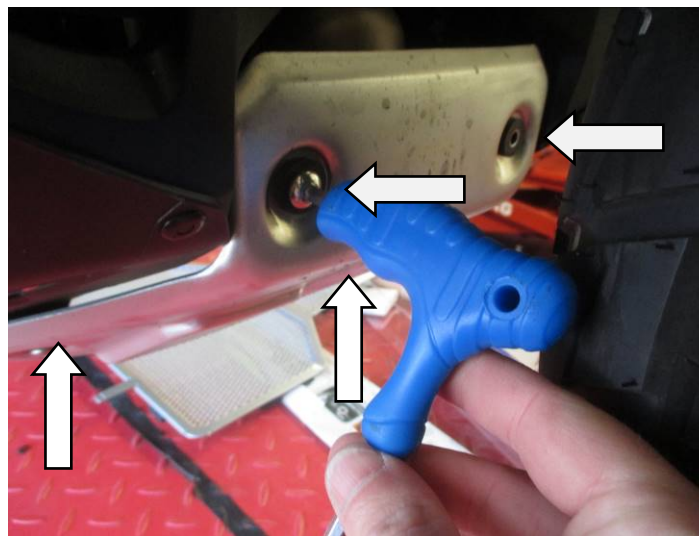

Picture 2

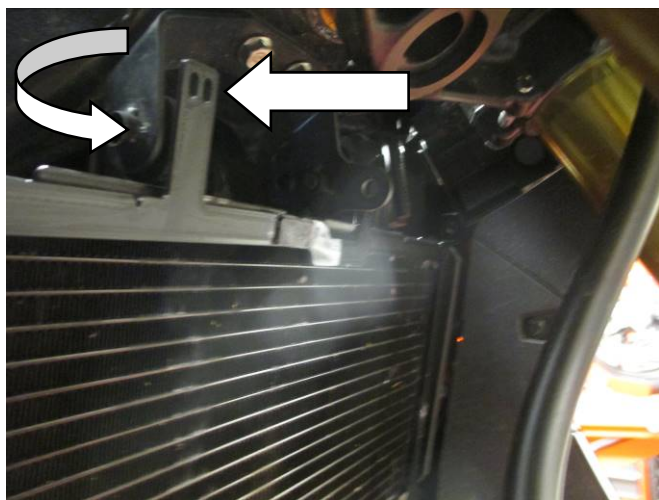

Picture 3



Picture 4

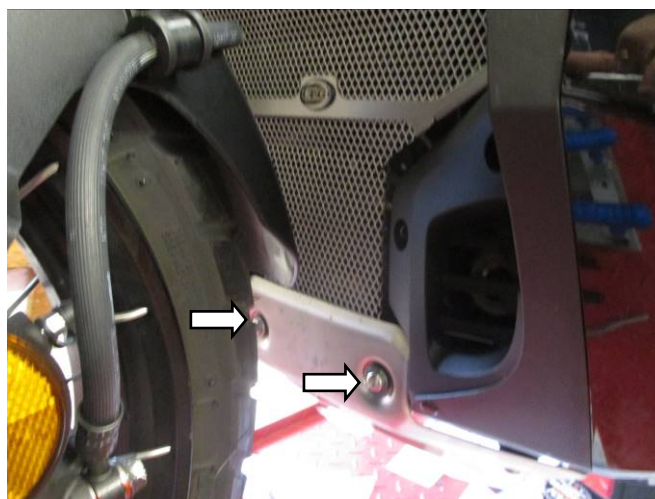

Picture 5  
R&G Racing



## **FITTING INSTRUCTIONS**

- To begin, cut the adhesive foam (item 4) provided into 10mm strips and affix onto the rear of the outer frame of each radiator guard in roughly the positions shown in **picture 1**.
- Remove the OEM bash plate from the bike by removing the 4 bolts arrowed in **picture 2** using an allen key.
- On the upper left-hand side (as you sit on the bike) of the radiator, loosen the horizontal radiator mount bolt at the top of the radiator using a 10mm spanner. It is not necessary to remove this bolt completely.
- Offer the radiator guard into position and slide the upper guard mount slot between the radiator and bolt head that was loosened, push back as necessary so the guard meets the radiator. Do not retighten at this stage.
- With the radiator guard correctly positioned, pass the cable tie provided (item 5) through the upper slot on the RHS of the radiator guard as shown in **picture 3**. Loop this around the radiator mount bracket and back through in order to secure the RHS of the guard to the radiator.
- Following the assembly diagram on page 2, The OEM bash guard can now be re-fitted to the bike, Take the two M5x25mm bolts (item 3) and M5 washers (item 4) to pass through the upper bash guard mounts, ensuring the bolts pass through the lower radiator guard (item 1) mounts as shown in **picture 4**.
- Fit the two lower bash guard mount bolts back into position.
- Before fully tightening all bolts, ensure the radiator guard is correctly adjusted and will not foul any moving components and does not contact the exhaust.
- Fully tighten all bolts, including tightening the upper radiator mount bolt to secure the radiator guard in place as shown in **picture 5**.
- Once secure, fully tighten and trim the excess cable tie tail from the cable tie using a pair of snips.
- Check all components are secure and all bolts are tight before riding.

ISSUE 1 – 15/12/2021 (DM)

### **CONSUMER NOTICE**

The catalogue description and any exhibition of samples are only broad indications of the Products and R&G may make design changes which do not diminish their performance or visual appeal and supplying them in such state shall conform to the order. The Buyer acknowledges no representation or warranty (other than as to title) has been given or will apply to the Products other than those in R&G's order or confirmation and the Buyer confirms it has chosen the Products as being of merchantable quality and suitable for its particular purposes. Where R&G fits the Products or undertakes other services it shall exercise reasonable skill and care and rectify any fault free of charge unless the workmanship has been disturbed. The Buyer is responsible for ensuring that the warranty on the motorcycle is not affected by the fitting of the Products. On return of any defective Products R&G shall at its option either supply a replacement or refund the purchase money but shall not be liable if the Products have been modified or used or maintained otherwise than in accordance with R&G's or manufacturer's instructions and good engineering practice or if the defect arises from accident or neglect. Other than identified above and subject to R&G not limiting its liability for causing death and personal injury, it shall not be liable for indirect or consequential loss and otherwise its liability shall be limited to the amounts paid by the Buyer for the Products or the fitting or service concerned. These terms do not affect the Buyer's statutory rights.

### **R&G RACING RETURNS POLICY (NON-FAULTY GOODS)**

Returns must be pre-authorized (if not pre-authorized the return will be rejected). Goods may only be returned direct to us if they were purchased direct from us (customer must prove if necessary). Otherwise to be returned to original vendor. Goods must be in re-sellable condition, in the opinion of R&G Racing. All returns are subject to a 25% restocking and handling fee (25% of the gross value exc. P&P – at the prevailing price at time of purchase). The customer must pay any and all carriage charges. No returns of discontinued products, unless within 14 days of purchase. This policy does not affect your statutory rights and does not refer to faulty goods.

R&G Racing

Unit 1, Shelley's Lane, East Worldham, Alton, Hampshire, GU34 3AQ

Tel: +44 (0)1420 89007 Fax: +44 (0)1420 87301 [www.rg-racing.com](http://www.rg-racing.com) Email: [info@rg-racing.com](mailto:info@rg-racing.com)





**MONTAGEANLEITUNG FÜR RAD0274**  
**KÜHLERSCHUTZ**  
**HONDA X-ADV 2021-**

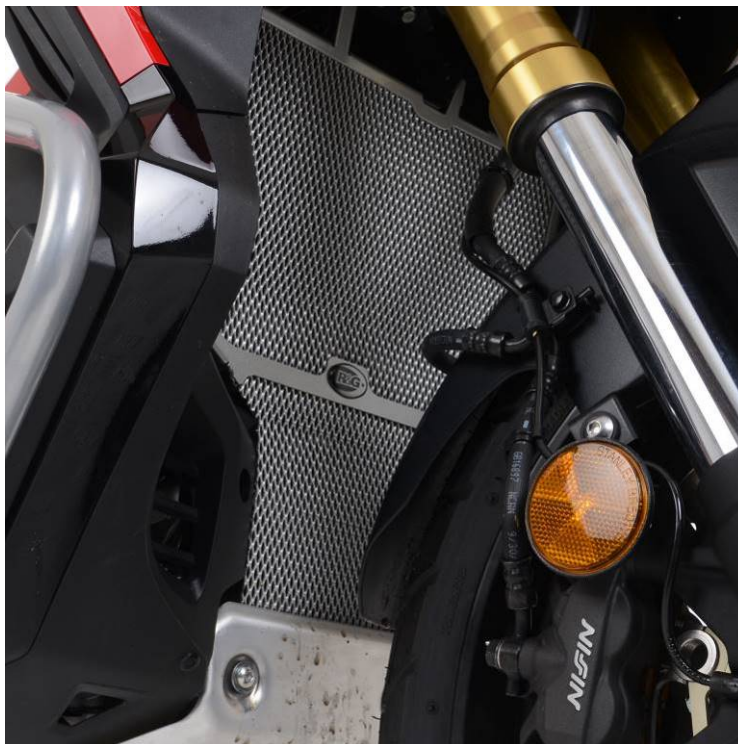

**ALLE KIT-TEILE SIND AUF DEN NACHFOLGENDEN SEITEN ABGEBILDET UND GEKENNZEICHNET.**

DIE ABGEBILDETEN TEILE DIENEN LEDIGLICH ZUR ERKLÄRUNG.

ÜBERPRÜFEN SIE ZUERST, DASS ALLE TEILE VORHANDEN SIND.

**LESEN SIE DIE MONTAGEANLEITUNG KOMPLETT DURCH, BEVOR SIE ANFANGEN.**

**WENN SIE BEI DER MONTAGE DIESES PRODUKTES UNSICHER SIND, BITTE EINEN UNSERER HÄNDLER KONTAKTIEREN ODER DAS KIT VON EINEM QUALIFIZIERTEN ZWEIRAD-MECHANIKER MONTIEREN LASSEN.**

DIE VERPACKUNG DER TEILE STELLT NICHT DIE REIHENFOLGE DER MONTAGE DAR.

HINWEIS FÜR KITS MIT PLASTIKUNTERLEGSCHLEIBEN AN DEN SCHRAUBEN –  
DIESE PLASTIK-UNTERLEGSCHLEIBEN WERDEN NICHT FÜR DEN EINBAU BENÖTIGT

**EINE DIGITALE VERSION DIESER MONTAGEANLEITUNG KANN AUF FOLGENDER SEITE HERUNTERGELADEN WERDEN:**

[WWW.RG-RACING.COM](http://WWW.RG-RACING.COM)

R&G Racing

Unit 1, Shelley's Lane, East Worldham, Alton, Hampshire, GU34 3AQ

Tel: +44 (0)1420 89007 Fax: +44 (0)1420 87301 [www.rg-racing.com](http://www.rg-racing.com) Email: [info@rg-racing.com](mailto:info@rg-racing.com)



<b><u>SIE BENÖTIGEN FOLGENDES WERKZEUG:</u></b>	<b><u>ALLGEM. ANZUGSDREHMOMENT</u></b>
<ul style="list-style-type: none"> <li>• SATZ INBUSSCHLÜSSEL</li> <li>• 10MM SCHRAUBENSCHLÜSSEL</li> <li>• SEITENSCHNEIDER ODER SCHERE</li> </ul>	M4 SCHRAUBE = 8Nm M5 SCHRAUBE = 12Nm M6 SCHRAUBE = 15Nm M8 SCHRAUBE = 20Nm M10 SCHRAUBE = 40Nm M12 SCHRAUBE = 40Nm

### **LIEFERUMFANG**

<b>ARTIKEL NR.</b>	<b>BESCHREIBUNG</b>	<b>MENGE</b>
ARTIKEL 1	RAD0274 KÜHLERSCHUTZ	1
ARTIKEL 2	M5x25mm INBUSSCHRAUBE	2
ARTIKEL 3	M5x20MM O/D UNTERLEGSCHIEBE	2
ARTIKEL 4	100mm SELBSTKLEBENDER SCHAUMSTOFF	3
ARTIKEL 5	2.5MM KABELBINDER	1

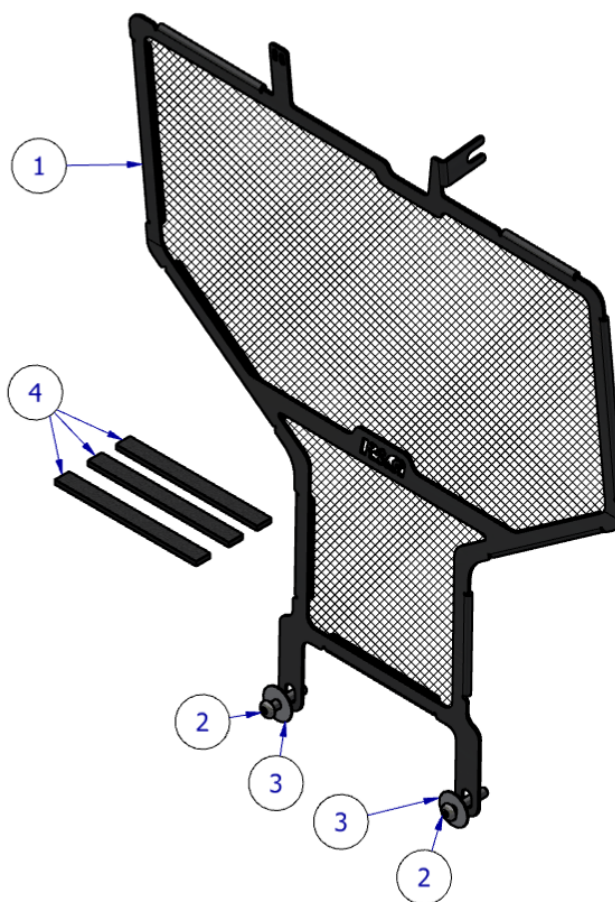

R&G Racing

Unit 1, Shelley's Lane, East Worldham, Alton, Hampshire, GU34 3AQ

Tel: +44 (0)1420 89007 Fax: +44 (0)1420 87301 [www.rg-racing.com](http://www.rg-racing.com) Email: [info@rg-racing.com](mailto:info@rg-racing.com)



**MONTAGE - ABBILDUNGEN**



Abbildung 1



Abbildung 2

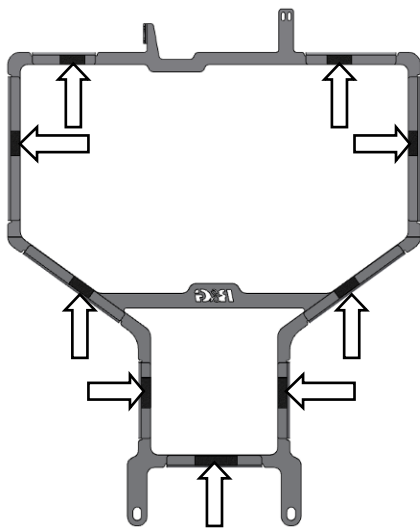

Abbildung 3

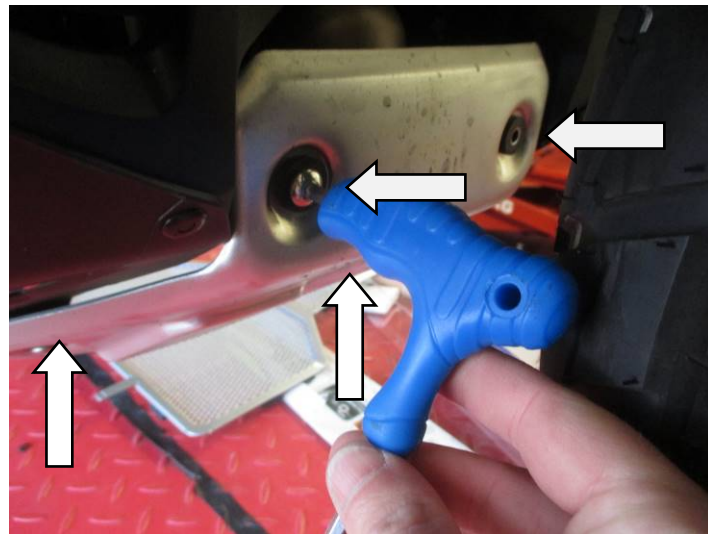

Abbildung 4

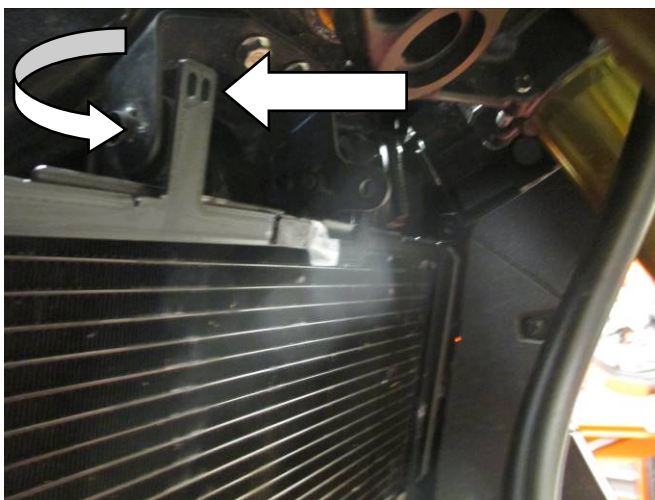

Abbildung 5

R&G Racing

Unit 1, Shelley's Lane, East Worldham, Alton, Hampshire, GU34 3AQ

Tel: +44 (0)1420 89007 Fax: +44 (0)1420 87301 [www.rg-racing.com](http://www.rg-racing.com) Email: [info@rg-racing.com](mailto:info@rg-racing.com)

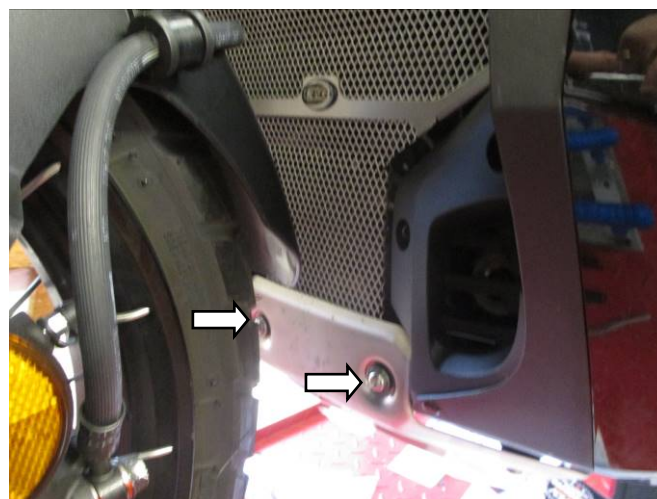



## **MONTAGEANLEITUNG**

- Schneiden Sie zuerst den selbstklebenden Schaumstoff vom Kit (Artikel 5) in 10mm Streifen und kleben Sie diese auf der Rückseite des äußeren Rahmens am jeweiligen Kühlerschutz – wenn möglich an den gleichen Positionen wie in **Abbildung 1** abgebildet.
- Entfernen Sie die original Metallschutzplatte, indem Sie die vier Schrauben, die in **Abbildung 2** gekennzeichnet sind mit einem Inbusschlüssel entfernen.
- An der oberen linken Seite (in Fahrtrichtung) des Kühlers, die horizontale Montageschrauben für den Kühler oben mit einem Steckschlüssel lösen. Es ist nicht notwendig, diese Schraube komplett zu entfernen.
- Den Kühlerschutz in Position bringen und den oberen Montageschlitz zwischen den Kühler und den gelösten Schraubenkopf schieben, ggfs. entsprechend zurückschieben, sodass der Kühlerschutz den Kühler trifft. Zu diesem Zeitpunkt nicht wieder anziehen.
- Wenn der Kühlerschutz ordnungsgemäß positioniert ist, einen Kabelbinder vom Kit (Artikel 5) durch den oberen Schlitz an der rechten Seite des Kühlerschutzes fädeln wie in **Abbildung 3** abgebildet. Dies um die Halterung für den Kühler wickeln und wieder zurück, um die rechte Seite des Kühlerschutzes am Kühler zu befestigen.
- Die Zeichnung Zusammenbau auf Seite 2 dient als Referenz für den nächsten Schritt: Die original Metallschutzplatte kann nun wieder am Motorrad montiert werden. Die zwei M5x25mm Schrauben (Artikel 3) und M5 Unterlegscheiben (Artikel 4) in die oberen Halterungen der Metallschutzplatte einsetzen und sicherstellen, dass die Schrauben durch die Halterungen für den unteren Kühlerschutz (Artikel 1) passen wie in **Abbildung 4** abgebildet.
- Montieren Sie die zwei unteren Originalschrauben für die Metallschutzplatte wieder.
- Bevor Sie alle Schrauben festziehen, überprüfen Sie, dass der Kühlerschutz ordnungsgemäß in Position montiert ist und dass der Kühlerschutz weder den Auspuff noch andere Teile, die sich bewegen, berührt.
- Ziehen Sie alle Schrauben fest, inklusiv der oberen Montageschraube für den Kühler, um den Kühlerschutz in Position zu befestigen wie in **Abbildung 5** abgebildet.
- Anschließend die Kabelbinder festziehen und überschüssiges Kabel mit einem Seitenschneider abschneiden.
- Überprüfen Sie, dass alle Komponenten sicher befestigt sind und alle Schrauben festgezogen sind, bevor Sie mit dem Motorrad fahren.

AUSGABE 1 – 15/12/2021 (DM)

### **CONSUMER NOTICE**

The catalogue description and any exhibition of samples are only broad indications of the Products and R&G may make design changes which do not diminish their performance or visual appeal and supplying them in such state shall conform to the order. The Buyer acknowledges no representation or warranty (other than as to title) has been given or will apply to the Products other than those in R&G's order or confirmation and the Buyer confirms it has chosen the Products as being of merchantable quality and suitable for its particular purposes. Where R&G fits the Products or undertakes other services it shall exercise reasonable skill and care and rectify any fault free of charge unless the workmanship has been disturbed. The Buyer is responsible for ensuring that the warranty on the motorcycle is not affected by the fitting of the Products. On return of any defective Products R&G shall at its option either supply a replacement or refund the purchase money but shall not be liable if the Products have been modified or used or maintained otherwise than in accordance with R&G's or manufacturer's instructions and good engineering practice or if the defect arises from accident or neglect. Other than identified above and subject to R&G not limiting its liability for causing death and personal injury, it shall not be liable for indirect or consequential loss and otherwise its liability shall be limited to the amounts paid by the Buyer for the Products or the fitting or service concerned. These terms do not affect the Buyer's statutory rights.

### **R&G RACING RETURNS POLICY (NON-FAULTY GOODS)**

Returns must be pre-authorized (if not pre-authorized the return will be rejected). Goods may only be returned direct to us if they were purchased direct from us (customer must prove if necessary). Otherwise to be returned to original vendor. Goods must be in re-sellable condition, in the opinion of R&G Racing. All returns are subject to a 25% restocking and handling fee (25% of the gross value exc. P&P – at the prevailing price at time of purchase). The customer must pay any and all carriage charges. No returns of discontinued products, unless within 14 days of purchase. This policy does not affect your statutory rights and does not refer to faulty goods.

R&G Racing

Unit 1, Shelley's Lane, East Worldham, Alton, Hampshire, GU34 3AQ

Tel: +44 (0)1420 89007 Fax: +44 (0)1420 87301 [www.rg-racing.com](http://www.rg-racing.com) Email: [info@rg-racing.com](mailto:info@rg-racing.com)