

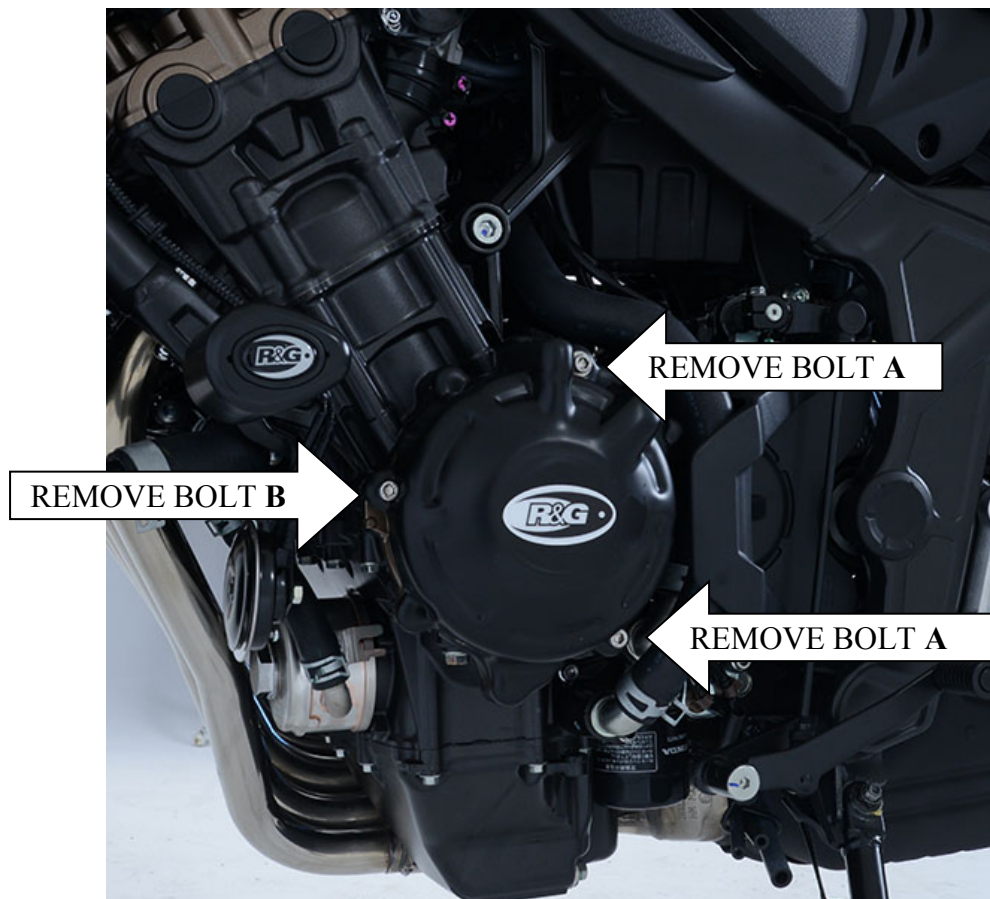

**FITTING INSTRUCTIONS FOR ECC0199 HONDA CBR650, CB650F 2013- & CB650R 2019- LHS ALTERNATOR COVER.**



Digital copies of these instructions are available to download from [www.rg-racing.com](http://www.rg-racing.com)

**GENERAL TORQUE SETTINGS**

- M4 BOLT = 8Nm
- M5 BOLT = 12Nm
- M6 BOLT = 15Nm
- M8 BOLT = 20Nm
- M10 BOLT = 40Nm

**TOOLS REQUIRED**

4 & 5 mm allen keys

**KIT CONTENTS:**

- ITEM 1 = PC0199
- ITEM 2 = M6 x 50mm BUTTON HEAD BOLTS **A** (2)
- ITEM 3 = M6 x 38mm BUTTON HEAD BOLT **B** (1)
- ITEM 4 = M6 WASHER 14mm DIA (3)
- ITEM 5 = S0376 SPACER (3)
- ITEM 6 = S0377 SPACER (3)

**PLEASE READ THESE INSTRUCTIONS FULLY BEFORE STARTING**

- Please make sure the engine is cold before proceeding with the fitting of the R&G cover.
- To fit the R&G engine case cover remove the three M6 engine case bolts in the positions arrowed above using a 5mm allen key. Hold the cover loosely over the case to help identify the correct ones.
- If not already installed, fit the two-part spacers (items 5 & 6) into the appropriate holes in the cover as indicated below and ensure they are correctly seated before mounting. A light tap from a hammer may help seat the spacer. **DO NOT USE EXCESSIVE FORCE.**

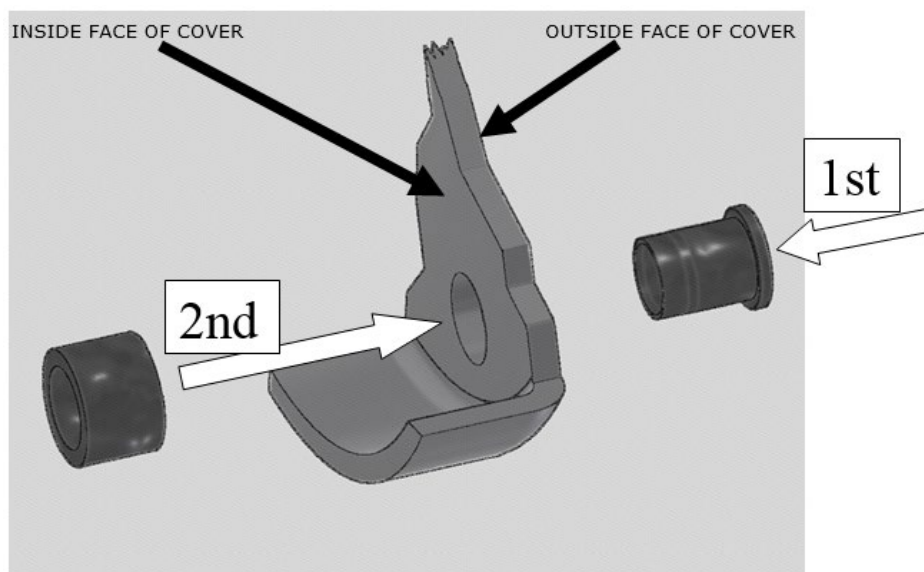

- Offer up the R&G cover to the engine and carefully fit it over the casing.
- Ensure that the R&G bolts spacers are lined up with the holes in the engine casing, and then push on as far as it will go.
- Using a washer (item 4) where possible, fit the correct length bolts as detailed by the letter in the 'kit contents' list, corresponding to the image on page 1. Fasten through the Engine Case Cover and into the engine case.
- With a 4mm Allen key tighten the bolts equally so that they pull the cover into place. **DO NOT FULLY TIGHTEN.**
- Finally use a torque wrench set at 10 N/m (7 Lb/ft) to fully tighten.
- It is suggested that you check the tightness of the mounting bolts on a regular basis i.e. when cleaning or once a month.
- NOTE; for the cleaning of this product you should only use a soft polishing cloth and a mild general cleaning agent.

R&amp;G

Unit 1, Shelley's Lane, East Worldham, Alton, Hampshire, GU34 3AQ

Tel: +44 (0)1420 89007 Fax: +44 (0)1420 87301 [www.rg-racing.com](http://www.rg-racing.com) Email: [info@rg-racing.com](mailto:info@rg-racing.com)



- AVOID HARMFUL CHEMICALS. IF IN DOUBT DO NOT USE AS THEY COULD ALTER THE STRENGTH OF THE COVER.
- R&G will accept no liability if the above procedure and torque settings are not followed.

ISSUE 1 28/02/2019 (DM)

#### **CONSUMER NOTICE**

The catalogue description and any exhibition of samples are only broad indications of the Products and R&G may make design changes which do not diminish their performance or visual appeal and supplying them in such state shall conform to the order. The Buyer acknowledges no representation or warranty (other than as to title) has been given or will apply to the Products other than those in R&G's order or confirmation and the Buyer confirms it has chosen the Products as being of merchantable quality and suitable for its particular purposes. Where R&G fits the Products or undertakes other services it shall exercise reasonable skill and care and rectify any fault free of charge unless the workmanship has been disturbed. The Buyer is responsible for ensuring that the warranty on the motorcycle is not affected by the fitting of the Products. On return of any defective Products R&G shall at its option either supply a replacement or refund the purchase money but shall not be liable if the Products have been modified or used or maintained otherwise than in accordance with R&G's or manufacturer's instructions and good engineering practice or if the defect arises from accident or neglect. Other than identified above and subject to R&G not limiting its liability for causing death and personal injury, it shall not be liable for indirect or consequential loss and otherwise its liability shall be limited to the amounts paid by the Buyer for the Products or the fitting or service concerned. These terms do not affect the Buyer's statutory rights.

#### **R&G RACING RETURNS POLICY (NON-FAULTY GOODS)**

Returns must be pre-authorized (if not pre-authorized the return will be rejected). Goods may only be returned direct to us if they were purchased direct from us (customer must prove if necessary). Otherwise to be returned to original vendor. Goods must be in re-sellable condition, in the opinion of R&G Racing. All returns are subject to a 25% restocking and handling fee (25% of the gross value exc. P&P – at the prevailing price at time of purchase). The customer must pay any and all carriage charges. No returns of discontinued products, unless within 14 days of purchase. This policy does not affect your statutory rights and does not refer to faulty goods.

R&G

Unit 1, Shelley's Lane, East Worldham, Alton, Hampshire, GU34 3AQ

Tel: +44 (0)1420 89007 Fax: +44 (0)1420 87301 [www.rg-racing.com](http://www.rg-racing.com) Email: [info@rg-racing.com](mailto:info@rg-racing.com)



**NOTICE DE MONTAGE POUR ECC0199 HONDA CBR650, CB650F 2013- & CB650R 2019- PROTECTION ALTERNATEUR GAUCHE.**

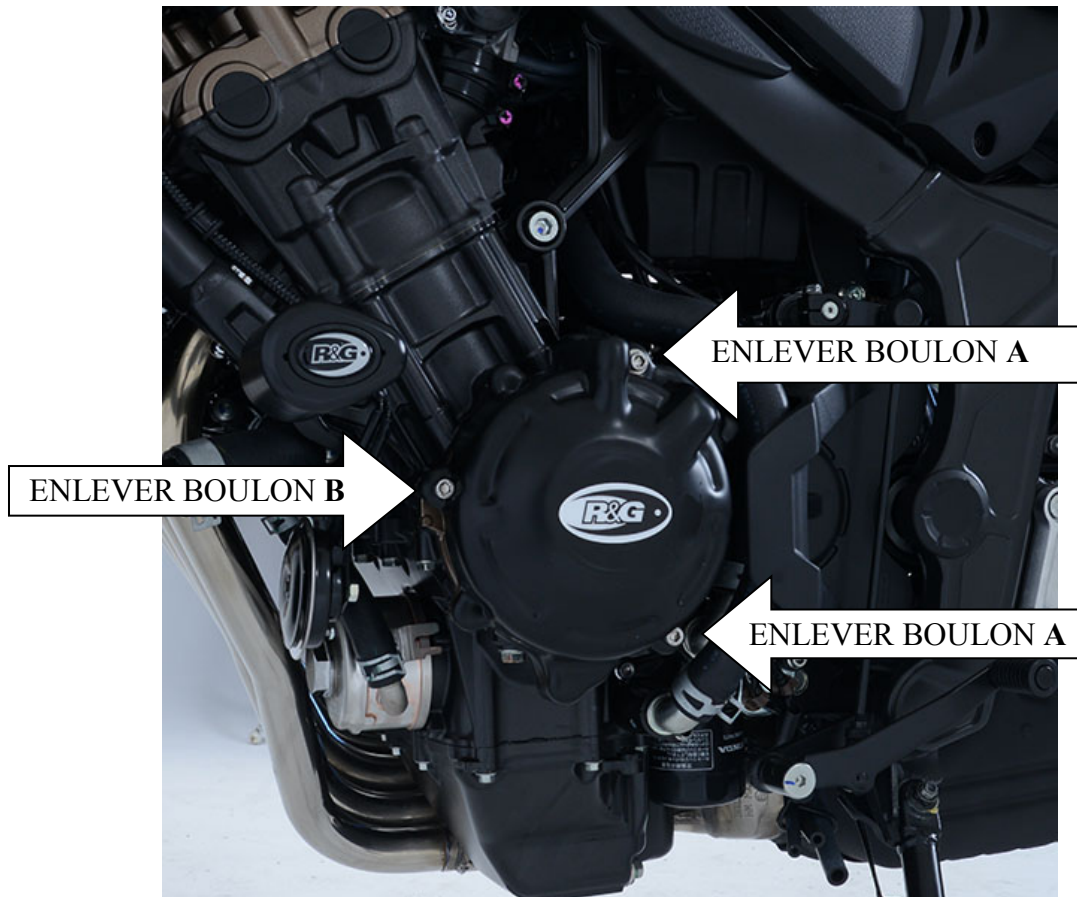

**Notice disponible au téléchargement sur [www.rg-racing.com](http://www.rg-racing.com)**

**Valeurs de serrage recommandées**

- M4 BOULON = 8Nm
- M5 BOULON = 12Nm
- M6 BOULON = 15Nm
- M8 BOULON = 20Nm
- M10 BOULON = 40Nm

**OUTILS REQUIS**

Clés Allen 4 & 5 mm

**CONTENU DU KIT :**

- ARTICLE 1 = PC0199
- ARTICLE 2 = M6 x 50mm BOULONS **A** (2)
- ARTICLE 3 = M6 x 38mm BOULON **B** (1)
- ARTICLE 4 = M6 RONDELLE 14mm DIA (3)
- ARTICLE 5 = S0376 ENTRETOISE (3)
- ARTICLE 6 = S0377 ENTRETOISE (3)

**LIRE LA NOTICE AVANT DE COMMENCER**

- Assurez-vous que le moteur soit froid.
- Pour monter la protection R&G, enlever les 3 boulons M6 dans les positions indiquées ci-dessus en utilisant une clé Allen 5mm. Tenir le couvercle autour du carter pour aider à les identifier.
- Si cela n'est pas déjà fait, insérez les entretoises en 2 parties (articles 5 & 6) dans les trous appropriés du cache, voir ci-dessous, puis veiller à ce qu'elles soient correctement placées avant le montage. Pour placer l'entretoise, vous pouvez utiliser un maillet léger. **NE PAS TAPER TROP FORT SUR LES ENTRETOISES.**

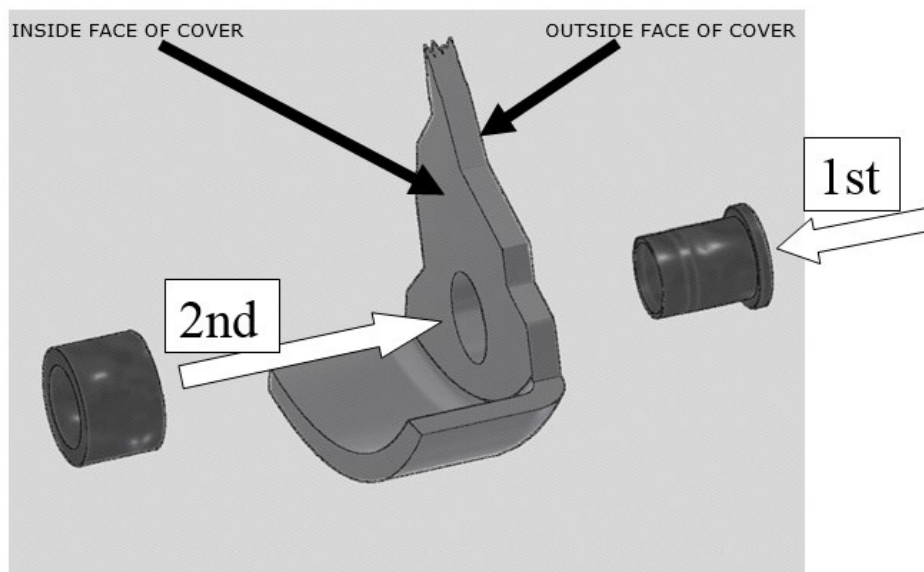

- Mettre la protection R&G en place en faisant bien attention.
- S'assurer que les entretoises de boulons R&G soient alignées avec les trous, puis, une fois cela vérifié, pousser la protection jusqu'à la limite.
- Utiliser une rondelle (article 4) où cela est possible, insérez les boulons adéquats comme détaillé dans le contenu du kit, ce qui correspond à la page 1. Serrer à travers la protection carter moteur puis dans le carter moteur.
- Serrer les boulons avec une clé Allen de 4mm, pour qu'ils positionnent correctement la protection.. **NE PAS SERRER COMPLETEMENT.**
- Utiliser une clé dynamométrique à 10 Nm (7 Lb ft) pour bloquer).
- Nous vous suggérons de vérifier le serrage au moins une fois par mois, lors du nettoyage par exemple.
- NOTE : Pour le nettoyage, vous devriez utiliser uniquement un chiffon doux et un agent nettoyant doux.
- Ne pas utiliser d'agents chimiques qui pourraient altérer l'efficacité de la protection.

R&amp;G

Unit 1, Shelley's Lane, East Worldham, Alton, Hampshire, GU34 3AQ

Tel: +44 (0)1420 89007 Fax: +44 (0)1420 87301 [www.rg-racing.com](http://www.rg-racing.com) Email: [info@rg-racing.com](mailto:info@rg-racing.com)



- R&G n'acceptera aucune responsabilité en cas de mauvais couple de serrage ou d'utilisation inappropriée d'agents nocifs.

ISSUE 1 28/02/2019 (DM)

#### **CONSUMER NOTICE**

The catalogue description and any exhibition of samples are only broad indications of the Products and R&G may make design changes which do not diminish their performance or visual appeal and supplying them in such state shall conform to the order. The Buyer acknowledges no representation or warranty (other than as to title) has been given or will apply to the Products other than those in R&G's order or confirmation and the Buyer confirms it has chosen the Products as being of merchantable quality and suitable for its particular purposes. Where R&G fits the Products or undertakes other services it shall exercise reasonable skill and care and rectify any fault free of charge unless the workmanship has been disturbed. The Buyer is responsible for ensuring that the warranty on the motorcycle is not affected by the fitting of the Products. On return of any defective Products R&G shall at its option either supply a replacement or refund the purchase money but shall not be liable if the Products have been modified or used or maintained otherwise than in accordance with R&G's or manufacturer's instructions and good engineering practice or if the defect arises from accident or neglect. Other than identified above and subject to R&G not limiting its liability for causing death and personal injury, it shall not be liable for indirect or consequential loss and otherwise its liability shall be limited to the amounts paid by the Buyer for the Products or the fitting or service concerned. These terms do not affect the Buyer's statutory rights.

#### **R&G RACING RETURNS POLICY (NON-FAULTY GOODS)**

Returns must be pre-authorized (if not pre-authorized the return will be rejected). Goods may only be returned direct to us if they were purchased direct from us (customer must prove if necessary). Otherwise to be returned to original vendor. Goods must be in re-sellable condition, in the opinion of R&G Racing. All returns are subject to a 25% restocking and handling fee (25% of the gross value exc. P&P – at the prevailing price at time of purchase). The customer must pay any and all carriage charges. No returns of discontinued products, unless within 14 days of purchase. This policy does not affect your statutory rights and does not refer to faulty goods.

R&G

Unit 1, Shelley's Lane, East Worldham, Alton, Hampshire, GU34 3AQ

Tel: +44 (0)1420 89007 Fax: +44 (0)1420 87301 [www.rg-racing.com](http://www.rg-racing.com) Email: [info@rg-racing.com](mailto:info@rg-racing.com)



**MONTAGEANLEITUNG FÜR ECC0199 HONDA CBR650, CB650F 2013- & CB650R 2019-ABDECKUNG LINKE SEITE (LICHTMASCHINE).**



**Eine digitale Version dieser Montageanleitung kann auf folgender Seite heruntergeladen werden: [www.rg-racing.com](http://www.rg-racing.com)**

**ALLGEMEINE ANZUGSDREHMOMENTE**

- M4 SCHRAUBE = 8Nm
- M5 SCHRAUBE = 12Nm
- M6 SCHRAUBE = 15Nm
- M8 SCHRAUBE = 20Nm
- M10 SCHRAUBE = 40Nm

**SIE BENÖTIGEN FOLGENDES**

4 & 5 mm Inbusschlüssel

**INHALT DES KITS:**

- ARTIKEL 1 = PC0199
- ARTIKEL 2 = M6 x 50mm INBUSSCHRAUBEN **A** (2)
- ARTIKEL 3 = M6 x 38mm INBUSSCHRAUBE **B** (1)
- ARTIKEL 4 = M6 UNTERLEGSSCHEIBE 14mm DIA (3)
- ARTIKEL 5 = S0376 DISTANZHALTER (3)
- ARTIKEL 6 = S0377 DISTANZHALTER (3)

**BITTE LESEN SIE DIE MONTAGEANLEITUNG DURCH, BEVOR SIE MIT DER MONTAGE BEGINNEN.**

- Bitte achten Sie unbedingt darauf, dass der Motor kalt ist, bevor Sie mit der Montage der R&G Abdeckung beginnen.
- Um die R&G Motorgehäuse-Abdeckung montieren zu können, entfernen Sie die drei M6 Motorgehäuse-Schrauben, die oben gekennzeichnet sind, mit einem 5mm Inbusschlüssel. Um die richtigen Schrauben identifizieren zu können, halten Sie die Abdeckung an das Gehäuse.
- Wenn der noch nicht bereits montiert ist, montieren Sie den zweiteiligen Distanzhalter (Artikel 5 & 6) an den entsprechenden Öffnungen in der Abdeckung wie unten angezeigt und stellen Sie sicher, dass die Teile richtig passen, bevor sie Sie montieren. Ein leichtes antippen mit einem Hammer hilft eventuell, den Distanzhalter in die richtige Position zu fixieren. KEINE ÜBERMÄSSIGE KRAFT ANWENDEN.

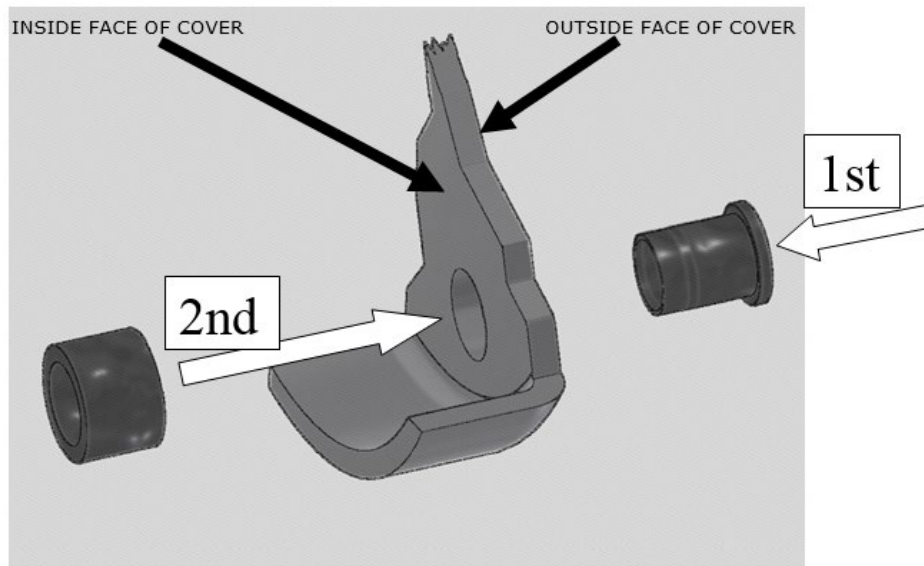

- Die R&G Abdeckung an den Motor ansetzen und vorsichtig am Gehäuse anbringen.
- Stellen Sie sicher, dass die drei R&G Schrauben mit den Bohrungen im Motorgehäuse ausgerichtet sind, und die Abdeckung soweit wie möglich eindrücken.
- Die Schrauben vom Kit mit einer Unterlegscheibe (wo dies möglich ist) durch die Motorgehäuse-Abdeckung ins Motorgehäuse einführen. Bitte beachten Sie, dass die richtigen Schrauben (diese sind mit Buchstaben gekennzeichnet in der Liste) an der jeweils vorgesehenen Position anbringen – siehe Abbildung auf Seite 1.

R&amp;G

Unit 1, Shelley's Lane, East Worldham, Alton, Hampshire, GU34 3AQ

Tel: +44 (0)1420 89007 Fax: +44 (0)1420 87301 [www.rg-racing.com](http://www.rg-racing.com) Email: [info@rg-racing.com](mailto:info@rg-racing.com)





- Ziehen Sie die Schrauben mit einem 4mm Inbusschlüssel gleichmäßig an, sodass sie die Abdeckung in Position ziehen. NICHT FESTZIEHEN.
- Anschließend benutzen Sie einen Drehmomentschlüssel, der auf 10 N/m (7 Lb/ft) eingestellt ist, um die Schrauben festzuziehen.
- Es wird empfohlen, die Festigkeit der Montageschrauben in regelmäßigen Abständen zu kontrollieren (d.h. einmal im Monat).
- HINWEIS: Bei der Reinigung dieses Produkts benutzen Sie nur ein weiches Poliertuch und ein mildes Putzmittel.
- VERMEIDEN SIE SCHÄDLICHE CHEMIKALIEN. IM ZWEIFELSFALL NICHT BENUTZEN, DA SIE DIE FESTIGKEIT DER ABDECKUNG VERÄNDERN KÖNNEN.
- R&G übernimmt keine Haftung, wenn die obengenannten Schritte nicht eingehalten werden und/oder die angegebenen Anzugsdrehmomente nicht angewendet werden.

AUSGABE 1 28/02/2019 (DM)

#### CONSUMER NOTICE

The catalogue description and any exhibition of samples are only broad indications of the Products and R&G may make design changes which do not diminish their performance or visual appeal and supplying them in such state shall conform to the order. The Buyer acknowledges no representation or warranty (other than as to title) has been given or will apply to the Products other than those in R&G's order or confirmation and the Buyer confirms it has chosen the Products as being of merchantable quality and suitable for its particular purposes. Where R&G fits the Products or undertakes other services it shall exercise reasonable skill and care and rectify any fault free of charge unless the workmanship has been disturbed. The Buyer is responsible for ensuring that the warranty on the motorcycle is not affected by the fitting of the Products. On return of any defective Products R&G shall at its option either supply a replacement or refund the purchase money but shall not be liable if the Products have been modified or used or maintained otherwise than in accordance with R&G's or manufacturer's instructions and good engineering practice or if the defect arises from accident or neglect. Other than identified above and subject to R&G not limiting its liability for causing death and personal injury, it shall not be liable for indirect or consequential loss and otherwise its liability shall be limited to the amounts paid by the Buyer for the Products or the fitting or service concerned. These terms do not affect the Buyer's statutory rights.

#### R&G RACING RETURNS POLICY (NON-FAULTY GOODS)

Returns must be pre-authorized (if not pre-authorized the return will be rejected). Goods may only be returned direct to us if they were purchased direct from us (customer must prove if necessary). Otherwise to be returned to original vendor. Goods must be in re-sellable condition, in the opinion of R&G Racing. All returns are subject to a 25% restocking and handling fee (25% of the gross value exc. P&P – at the prevailing price at time of purchase). The customer must pay any and all carriage charges. No returns of discontinued products, unless within 14 days of purchase. This policy does not affect your statutory rights and does not refer to faulty goods.

R&G

Unit 1, Shelley's Lane, East Worldham, Alton, Hampshire, GU34 3AQ

Tel: +44 (0)1420 89007 Fax: +44 (0)1420 87301 [www.rg-racing.com](http://www.rg-racing.com) Email: [info@rg-racing.com](mailto:info@rg-racing.com)