



FITTING INSTRUCTIONS FOR CP0547 AERO CRASH PROTECTORS
APRILIA 660 TUAREG 2022-



THIS KIT CONTAINS THE ITEMS PICTURED AND LABELLED OVER PAGE.

SOME PARTS MAY BE SHOWN FOR CLARITY OF INSTRUCTIONS ONLY.

DO NOT PROCEED UNTIL YOU ARE SURE ALL PARTS ARE PRESENT.

PLEASE READ ALL INSTRUCTIONS BEFORE PROCEEDING.

**IF IN ANY DOUBT WHEN FITTING OUR PRODUCTS, CONSULT ONE OF OUR DEALERS
OR HAVE FITTED BY A QUALIFIED TECHNICIAN.**

PLEASE NOTE THAT THE WAY THE KIT IS PACKED DOES NOT NECESSARILY REPRESENT THE WAY OF
MOUNTING TO THE BIKE.

IN THE EVENT OF RUBBER WASHERS BEING USED TO HOLD COMPONENTS ONTO BOLTS,
THESE RUBBER WASHERS CAN BE THROWN AWAY.

DIGITAL COPIES OF THESE INSTRUCTIONS ARE AVAILABLE FROM:

WWW.RG-RACING.COM



<u>TOOLS REQUIRED</u>	<u>GENERAL TORQUE SETTINGS</u>
<ul style="list-style-type: none"> • SOCKET & WRENCH SET INCLUDING 17mm and 19mm SOCKETS. • HEX BIT SOCKETS • TORQUE WRENCH (UP TO 50Nm) • SUITABLE SUPPORT JACK 	M4 BOLT = 8Nm M5 BOLT = 12Nm M6 BOLT = 15Nm M8 BOLT = 20Nm M10 BOLT = 40Nm M12 BOLT = 40Nm

LEGEND

ITEM NO.	DESCRIPTION	QTY
ITEM 1	M0714 LHS MOUNTING PLATE	1
ITEM 2	M0715 RHS MOUNTING PLATE	1
ITEM 3	S1430 (36mm SPACER)	1
ITEM 4	S1431 (30mm SPACER)	1
ITEM 5	B0061 AERO STYLE BOBBIN	2
ITEM 6	S1340 AERO STYLE SPACER	2
ITEM 7	M10x1.50x70mm CAP HEAD BOLT	4
ITEM 8	M10x1.5x85mm HEX HEAD BOLT	2
ITEM 9	BC0002 BOBBIN CAP	2
ITEM 10	M10 WASHER (17mm OUTSIDE DIAMETER)	4
ITEM 11	M10 WASHER (19mm OUTSIDE DIAMETER)	2
ITEM 12	LW0001 M12 SHAKE PROOF WASHER	2
ITEM 13	NC0010 M10 FLAT CAPS	4
ITEM 14	S1437 (25MM SPACER)	1
ITEM 15	S1438 (40MM SPACER)	1

R&G Racing

Unit 1, Shelley's Lane, East Worldham, Alton, Hampshire, GU34 3AQ

Tel: +44 (0)1420 89007 Fax: +44 (0)1420 87301 www.rg-racing.com Email: info@rg-racing.com



AERO-STYLE CRASH PROTECTOR ORIENTATION



EXPLODED ASSEMBLY VIEW

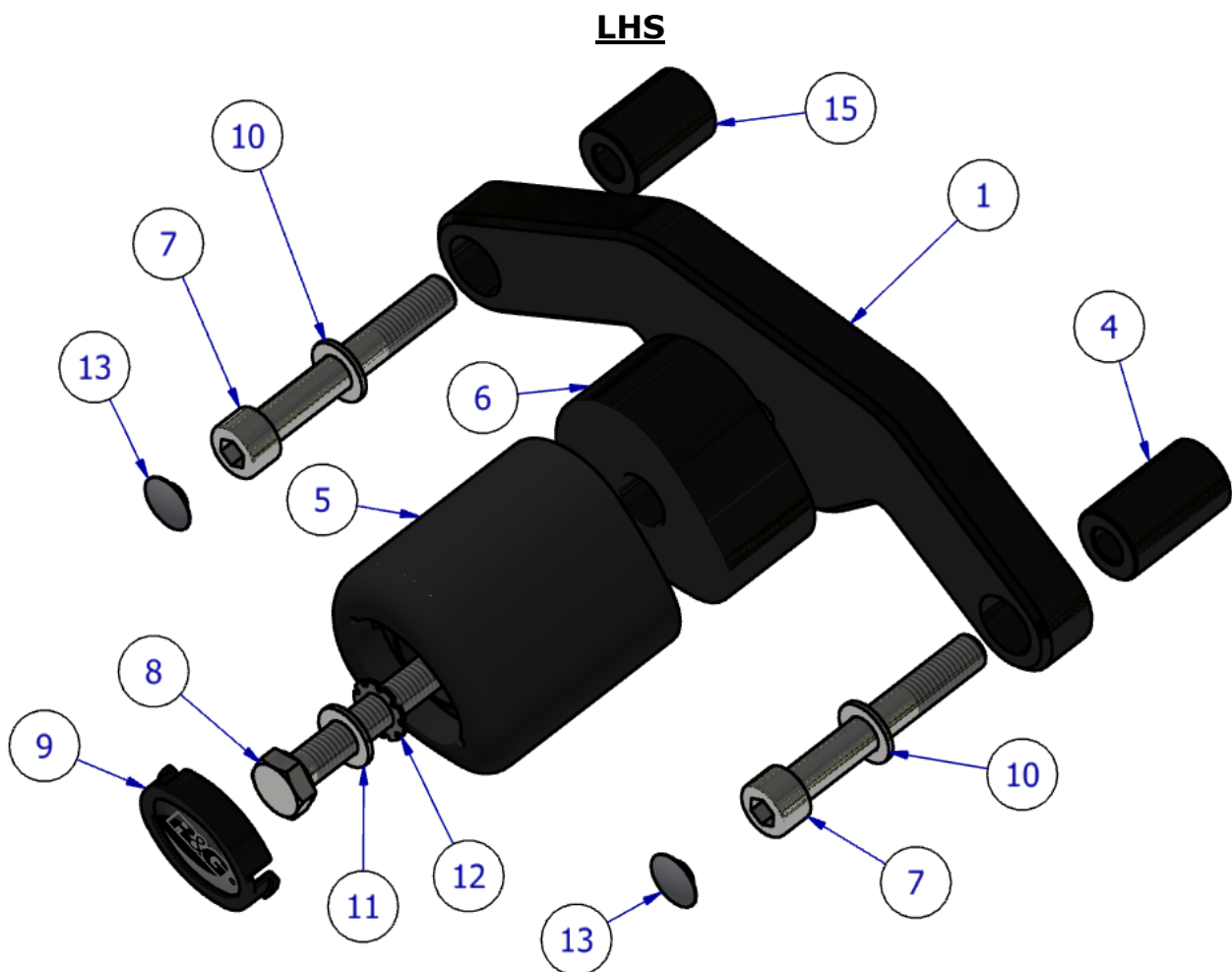



RHS

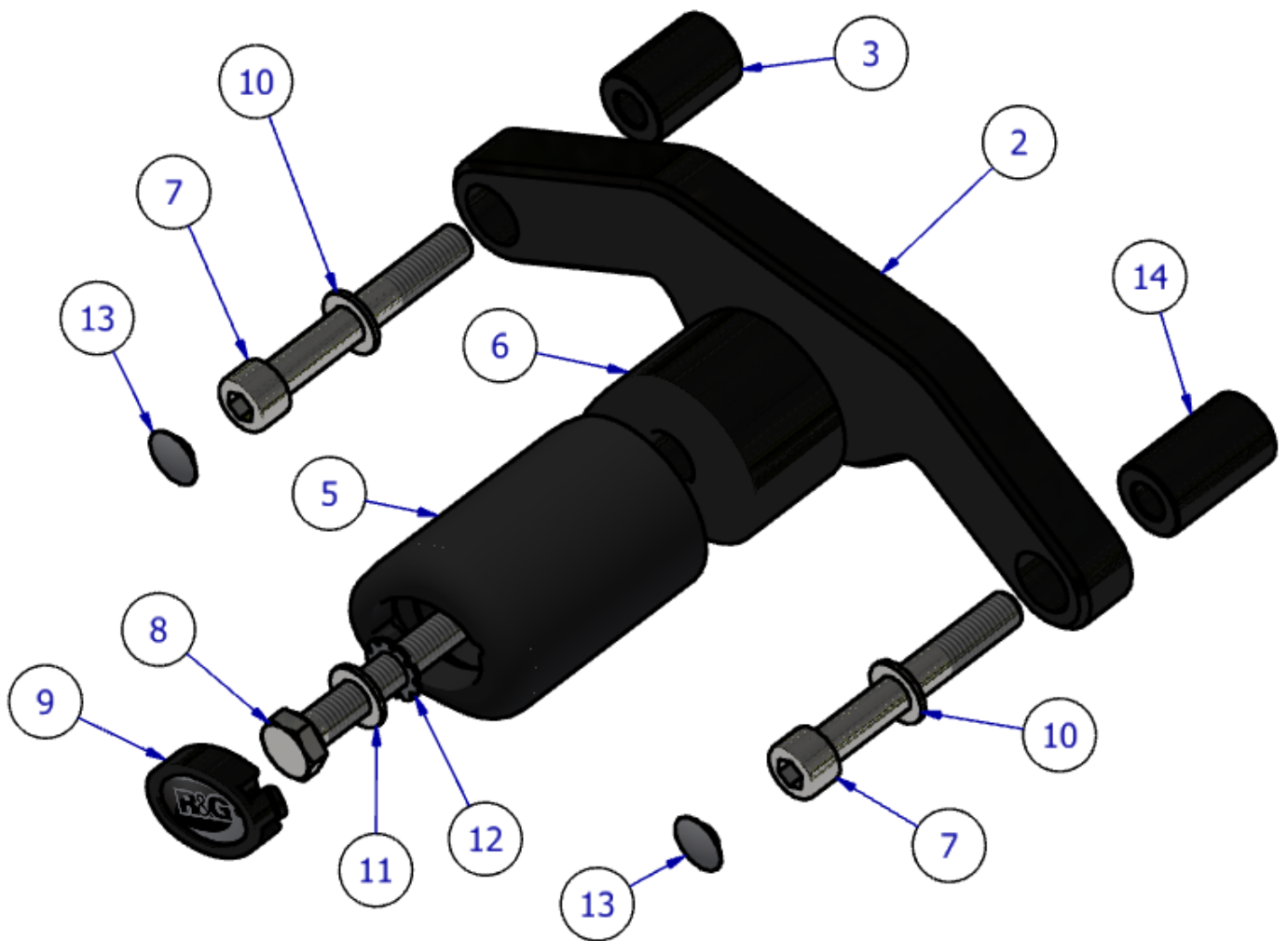
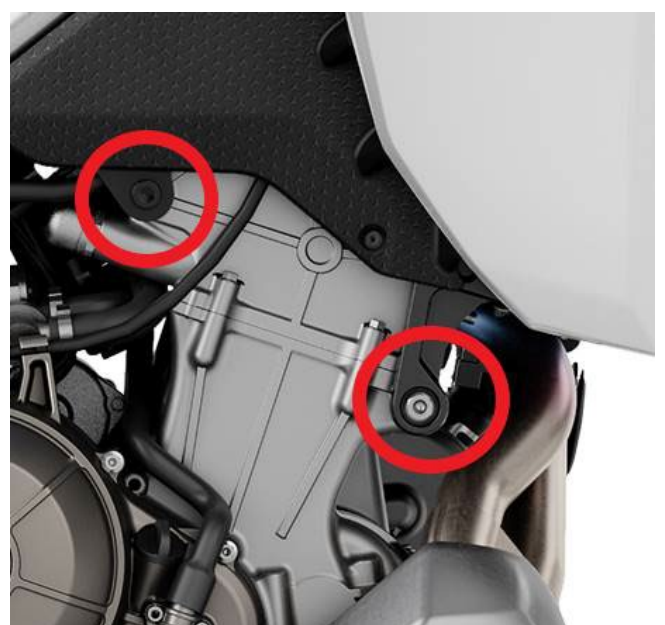
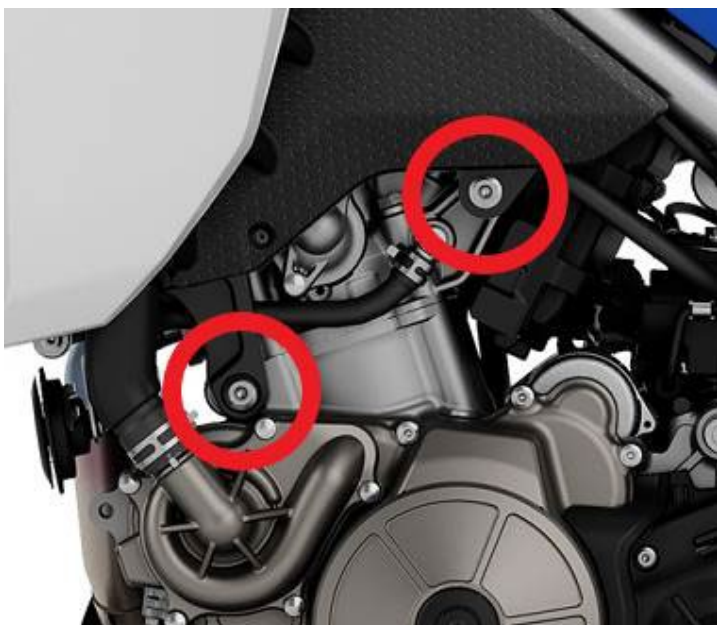

PHOTO 1

PHOTO 2



R&G Racing

Unit 1, Shelley's Lane, East Worldham, Alton, Hampshire, GU34 3AQ

Tel: +44 (0)1420 89007 Fax: +44 (0)1420 87301 www.rg-racing.com Email: info@rg-racing.com



FITTING INSTRUCTIONS

Before removing engine bolts, ensure the bike is upright and supported by a suitable engine stand or jack placed under the sump of the motorbike with a piece of wood or plastic between the engine and jack to support the partial weight of the engine, this will prevent the engine from moving during fitting.

INSTALLATION

1. Assemble the crash protectors as show in the **EXPLODED ASSEMBLY VIEW**.
2. Remove OEM engine bolts from the left-hand side as shown in **PHOTO 1**.
3. Once you have removed the OEM bolts, place the LHS Assembly up to the mounting holes ensuring the orientation is correct as shown above on **PAGE 3 (AERO-STYLE CRASH PROTECTOR ORIENTATION)**.
4. Now hand tighten the crash protector to allow the bolt threads to catch correctly.
5. Tighten the bolts to the correct Torque setting as show on **PAGE 2 (GENERAL TORQUE SETTINGS)**.
6. Once you have mounted the left-hand side, remove the right-hand side OEM engine bolts as shown in **PHOTO 2**.
7. Once you have removed the OEM bolts, place the RHS Assembly up to the mounting holes ensuring the orientation is correct as shown above on **PAGE 3 (AERO-STYLE CRASH PROTECTOR ORIENTATION)**.
8. **Repeat step 4 and 5.**
9. Ensure all bolts are tight and in correct orientation.
10. If not already fitted, fit bubble sticker into recess of the crash protector cap.
11. Fit crash protector cap into the crash protector.

ISSUE 2 – 28/10/2022 – JH

CONSUMER NOTICE

The catalogue description and any exhibition of samples are only broad indications of the Products and R&G may make design changes which do not diminish their performance or visual appeal and supplying them in such state shall conform to the order. The Buyer acknowledges no representation or warranty (other than as to title) has been given or will apply to the Products other than those in R&G's order or confirmation and the Buyer confirms it has chosen the Products as being of merchantable quality and suitable for its particular purposes. Where R&G fits the Products or undertakes other services it shall exercise reasonable skill and care and rectify any fault free of charge unless the workmanship has been disturbed. The Buyer is responsible for ensuring that the warranty on the motorcycle is not affected by the fitting of the Products. On return of any defective Products R&G shall at its option either supply a replacement or refund the purchase money but shall not be liable if the Products have been modified or used or maintained otherwise than in accordance with R&G's or manufacturer's instructions and good engineering practice or if the defect arises from accident or neglect. Other than identified above and subject to R&G not limiting its liability for causing death and personal injury, it shall not be liable for indirect or consequential loss and otherwise its liability shall be limited to the amounts paid by the Buyer for the Products or the fitting or service concerned. These terms do not affect the Buyer's statutory rights.

R&G RACING RETURNS POLICY (NON-FAULTY GOODS)

Returns must be pre-authorized (if not pre-authorized the return will be rejected). Goods may only be returned direct to us if they were purchased direct from us (customer must prove if necessary). Otherwise to be returned to original vendor. Goods must be in re-sellable condition, in the opinion of R&G Racing. All returns are subject to a 25% restocking and handling fee (25% of the gross value exc. P&P – at the prevailing price at time of purchase). The customer must pay any and all carriage charges. No returns of discontinued products, unless within 14 days of purchase. This policy does not affect your statutory rights and does not refer to faulty goods.

R&G Racing

Unit 1, Shelley's Lane, East Worldham, Alton, Hampshire, GU34 3AQ

Tel: +44 (0)1420 89007 Fax: +44 (0)1420 87301 www.rg-racing.com Email: info@rg-racing.com



MONTAGEANLEITUNG FÜR CP0547 AERO STURZPADS
APRILIA 660 TUAREG 2022-



ALLE KIT-TEILE SIND AUF DEN NACHFOLGENDEN SEITEN ABGEBILDET UND GEKENNZEICHNET.

DIE ABGEBILDETEN TEILE DIENEN LEDIGLICH ZUR ERKLÄRUNG.
ÜBERPRÜFEN SIE ZUERST, DASS ALLE TEILE VORHANDEN SIND.

LESEN SIE DIE MONTAGEANLEITUNG KOMPLETT DURCH, BEVOR SIE ANFANGEN.

**WENN SIE BEI DER MONTAGE DIESES PRODUKTES UNSICHER SIND, BITTE EINEN
UNSERER HÄNDLER KONTAKTIEREN ODER DAS KIT VON EINEM QUALIFIZIERTEN
ZWEIRAD-MECHANIKER MONTIEREN LASSEN.**

DIE VERPACKUNG DER TEILE STELLT NICHT DIE REIHENFOLGE DER MONTAGE DAR.

HINWEIS FÜR KITS MIT PLASTIKUNTERLEGSCHLEIBEN AN DEN SCHRAUBEN –
DIESE PLASTIK-UNTERLEGSCHLEIBEN WERDEN NICHT FÜR DEN EINBAU BENÖTIGT.

**EINE DIGITALE VERSION DIESER MONTAGEANLEITUNG KANN AUF
FOLGENDER SEITE HERUNTERGELADEN WERDEN:**

WWW.RG-RACING.COM



<u>SIE BENÖTIGEN FOLGENDES WERKZEUG:</u>	<u>ALLGEM. ANZUGSDREHMOMENT:</u>
<ul style="list-style-type: none"> • STECKSCHLÜSSELSATZ INKL. 17mm und 19mm STECKSCHLÜSSEL • INBUSEINSÄTZE • DREHMOMENTSCHLÜSSEL (BIS 50Nm) • PASSENDEN MONTAGESTÄNDER / MOTORRADHEBER 	<p>M4 SCHRAUBE = 8Nm M5 SCHRAUBE = 12Nm M6 SCHRAUBE = 15Nm M8 SCHRAUBE = 20Nm M10 SCHRAUBE = 40Nm M12 SCHRAUBE = 40Nm</p>

LIEFERUMFANG

ARTIKEL NR.	BESCHREIBUNG	MENGE
ARTIKEL 1	M0714 LINKE SEITE MONTAGEPLATTE	1
ARTIKEL 2	M0715 RECHTE SEITE MONTAGEPLATTE	1
ARTIKEL 3	S1430 (36mm DISTANZHALTER)	1
ARTIKEL 4	S1431 (30mm DISTANZHALTER)	1
ARTIKEL 5	B0061 AERO STURZPAD	2
ARTIKEL 6	S1340 AERO DISTANZHALTER	2
ARTIKEL 7	M10x1.50x70mm INNENSECHSKANTSCHRAUBE	4
ARTIKEL 8	M10x1.5x85mm SECHSKANTSCHRAUBE	2
ARTIKEL 9	BC0002 STURZPADKAPPE	2
ARTIKEL 10	M10 UNTERLEGSCHEIBE (17mm AUSSENDURCHMESSER)	4
ARTIKEL 11	M10 UNTERLEGSCHEIBE (19mm AUSSENDURCHMESSER)	2
ARTIKEL 12	LW0001 M12 ZAHNSCHEIBE	2
ARTIKEL 13	NC0010 M10 FLACHE KAPPEN	4
ARTIKEL 14	S1437 (25MM DISTANZHALTER)	1
ARTIKEL 15	S1438 (40MM DISTANZHALTER)	1

AERO-STYLE STURZPAD - ORIENTIERUNG

R&G Racing

Unit 1, Shelley's Lane, East Worldham, Alton, Hampshire, GU34 3AQ

Tel: +44 (0)1420 89007 Fax: +44 (0)1420 87301 www.rg-racing.com Email: info@rg-racing.com



ZUSAMMENBAU - EXPLOSIONSZEICHNUNG

LINKE SEITE

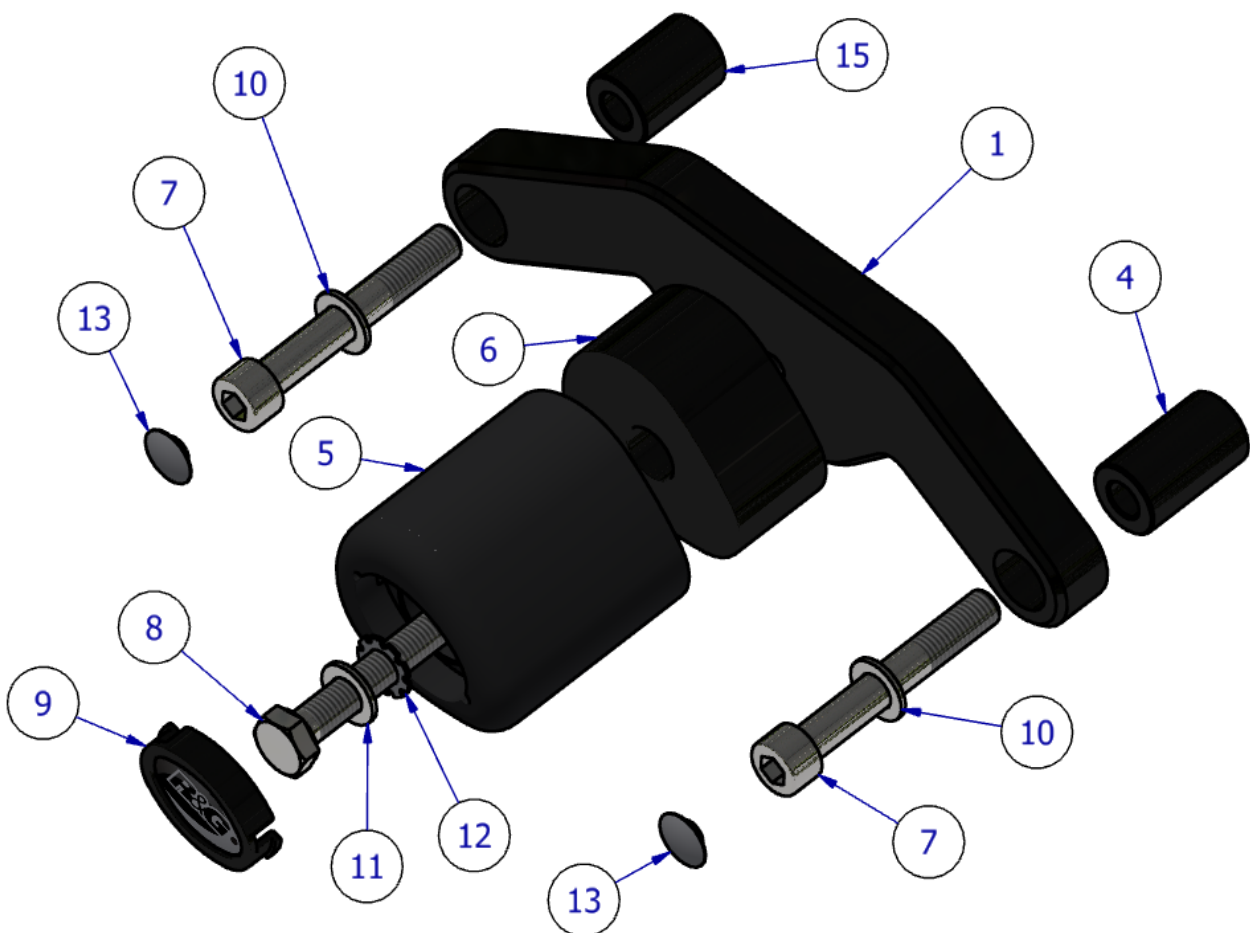



RECHTE SEITE



ABBILDUNG 1

ABBILDUNG 2

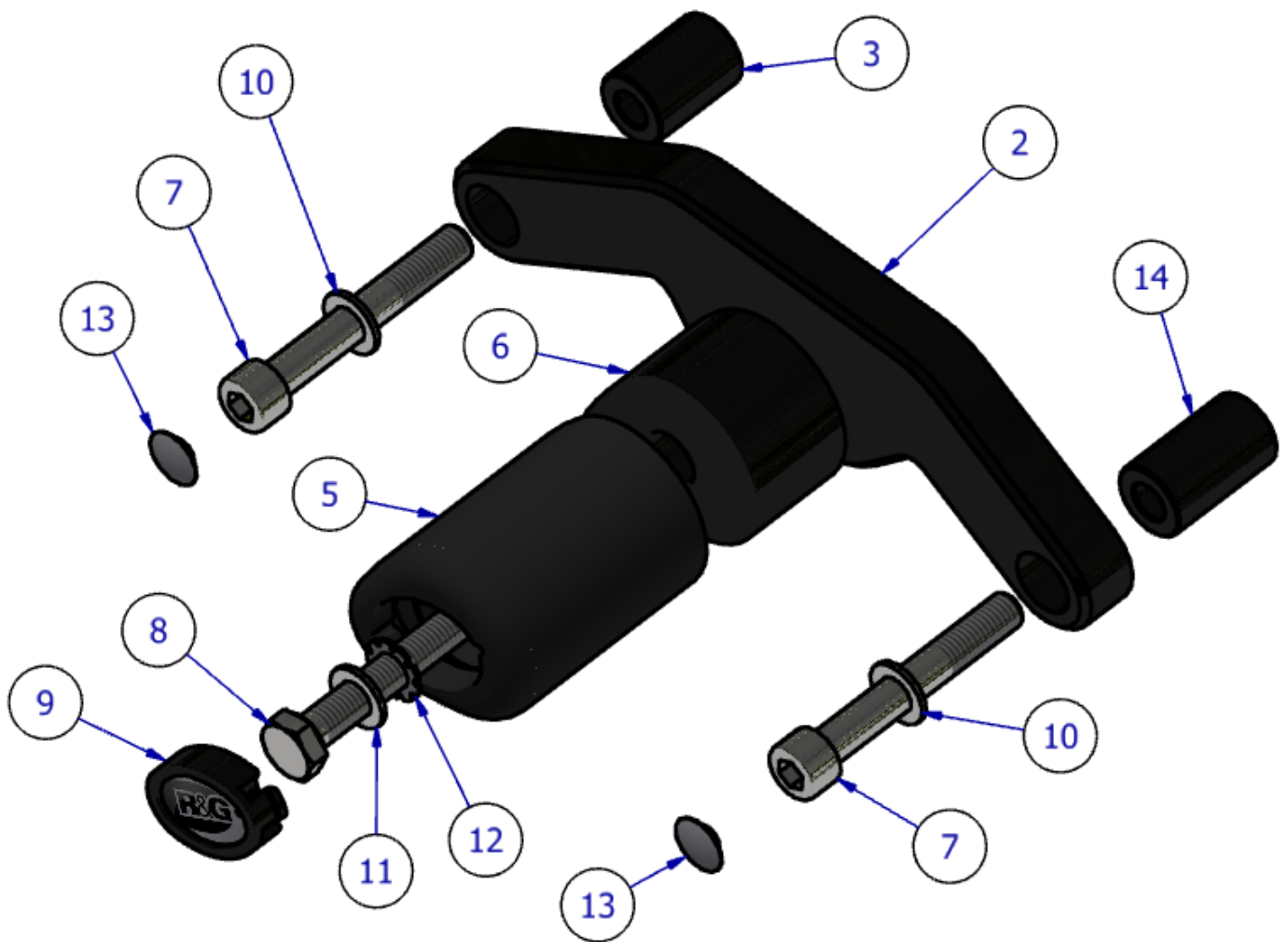
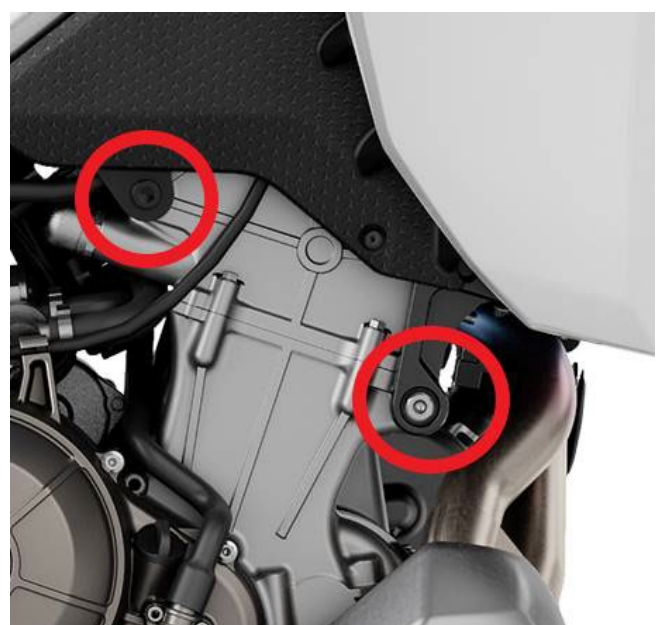
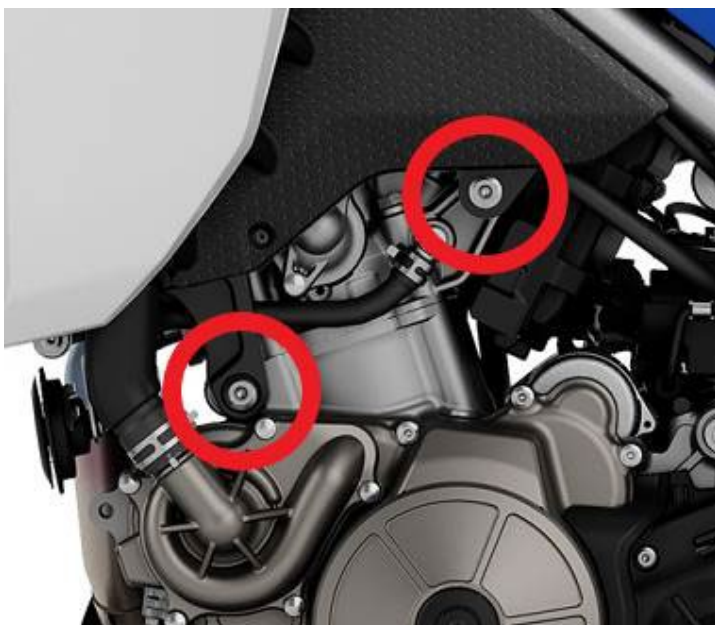

R&G Racing

Unit 1, Shelley's Lane, East Worldham, Alton, Hampshire, GU34 3AQ

Tel: +44 (0)1420 89007 Fax: +44 (0)1420 87301 www.rg-racing.com Email: info@rg-racing.com



MONTAGEANLEITUNG

Bevor Sie die Schrauben für den Motor entfernen, stellen Sie sicher, dass das Motorrad aufrecht steht und der Motor mit einem geeigneten Ständer/Heber unterhalb der Ölwanne gestützt ist. Ein kleines Stück Holz sollte zusätzlich zwischen Montagepunkt und Heber platziert werden, um die Last zu verteilen. Dies verhindert, dass der Motor sich bei der Entfernung von Motorschrauben bewegt.

MONTAGE:

1. Bauen Sie die Sturz pads zusammen wie in der **EXPLOSIONSZEICHNUNG** abgebildet.
2. Entfernen Sie die Originalschrauben an der linken Seite des Motors wie in **ABBILDUNG 1** abgebildet.
3. Nachdem die Originalschrauben entfernt wurden, den Zusammenbau für die linke Seite an die Montageöffnungen ansetzen – Die Ausrichtung des Zusammenbaus ist wie oben auf **SEITE 3 (AERO-STYLE STURZPAD - ORIENTIERUNG)** abgebildet.
4. Das Sturzpad nun mit der Hand anziehen, sodass die Schraubengewinde sich richtig eindrehen.
5. Die Schrauben mit dem empfohlenen Anzugsdrehmoment festziehen – siehe **SEITE 2 (ALLGEM. ANZUGSDREHMOMENT)**.
6. Wenn die linke Seite ordnungsgemäß montiert ist, entfernen Sie die Originalschrauben für den Motor an der rechten Seite wie in **ABBILDUNG 2** abgebildet.
7. Nachdem die Originalschrauben entfernt wurden, den Zusammenbau für die rechte Seite an die Montageöffnungen ansetzen – Die Ausrichtung des Zusammenbaus ist wie oben auf **SEITE 3 (AERO-STYLE STURZPAD - ORIENTIERUNG)** abgebildet.
8. **Wiederholen Sie Schritte 4 und 5 (rechte Seite).**
9. Stellen Sie sicher, dass alle Schrauben ordnungsgemäß eingedreht und festgezogen sind.
10. Wenn noch nicht bereits montiert, montieren Sie die Bubble-Aufkleber in den Vertiefungen der Sturzpad-Schutzkappen.
11. Die Schutzkappen an den Sturz pads montieren.

AUSGABE 2 – 28/10/2022 – JH

CONSUMER NOTICE

The catalogue description and any exhibition of samples are only broad indications of the Products and R&G may make design changes which do not diminish their performance or visual appeal and supplying them in such state shall conform to the order. The Buyer acknowledges no representation or warranty (other than as to title) has been given or will apply to the Products other than those in R&G's order or confirmation and the Buyer confirms it has chosen the Products as being of merchantable quality and suitable for its particular purposes. Where R&G fits the Products or undertakes other services it shall exercise reasonable skill and care and rectify any fault free of charge unless the workmanship has been disturbed. The Buyer is responsible for ensuring that the warranty on the motorcycle is not affected by the fitting of the Products. On return of any defective Products R&G shall at its option either supply a replacement or refund the purchase money but shall not be liable if the Products have been modified or used or maintained otherwise than in accordance with R&G's or manufacturer's instructions and good engineering practice or if the defect arises from accident or neglect. Other than identified above and subject to R&G not limiting its liability for causing death and personal injury, it shall not be liable for indirect or consequential loss and otherwise its liability shall be limited to the amounts paid by the Buyer for the Products or the fitting or service concerned. These terms do not affect the Buyer's statutory rights.

R&G Racing

Unit 1, Shelley's Lane, East Worldham, Alton, Hampshire, GU34 3AQ

Tel: +44 (0)1420 89007 Fax: +44 (0)1420 87301 www.rg-racing.com Email: info@rg-racing.com

**R&G RACING RETURNS POLICY (NON-FAULTY GOODS)**

Returns must be pre-authorized (if not pre-authorized the return will be rejected). Goods may only be returned direct to us if they were purchased direct from us (customer must prove if necessary). Otherwise to be returned to original vendor. Goods must be in re-sellable condition, in the opinion of R&G Racing. All returns are subject to a 25% restocking and handling fee (25% of the gross value exc. P&P – at the prevailing price at time of purchase). The customer must pay any and all carriage charges. No returns of discontinued products, unless within 14 days of purchase. This policy does not affect your statutory rights and does not refer to faulty goods.

R&G Racing

Unit 1, Shelley's Lane, East Worldham, Alton, Hampshire, GU34 3AQ

Tel: +44 (0)1420 89007 Fax: +44 (0)1420 87301 www.rg-racing.com Email: info@rg-racing.com



NOTICE DE MONTAGE POUR CP0547 PROTECTIONS CRASH
APRILIA 660 TUAREG 2022-



CE KIT CONTIENT LES ARTICLES ILLUSTRÉS ET ÉTIQUETES SUR LA PAGE.

CERTAINES PARTIES PEUVENT ÊTRE PRÉSENTES UNIQUEMENT POUR LA CLARTÉ DES INSTRUCTIONS.

NE PAS PROCÉDER AU MONTAGE TANT QUE VOUS N'ÊTES PAS SÛR QUE TOUTES LES PIÈCES SOIENT PRÉSENTES.

VEUILLEZ LIRE TOUTES LES INSTRUCTIONS AVANT DE CONTINUER.

EN CAS DE DOUTE LORS DU MONTAGE DE NOS PRODUITS, CONSULTEZ UN DE NOS REVENDUEURS OU FAITES APPEL À UN TECHNICIEN QUALIFIÉ.

VEUILLEZ NOTER QUE LA FAÇON DONT LE KIT EST EMBALLÉ NE REPRÉSENTE PAS NECESSAIREMENT LA MANIÈRE DE LE MONTER SUR LA MOTO.

SI DES RONDELLES EN CAOUTCHOUC SONT UTILISÉES POUR MAINTENIR LES COMPOSANTS SUR LES BOULONS, ELLES PEUVENT ÊTRE JETÉES.

NOTICE DISPONIBLE AU TÉLÉCHARGEMENT SUR :

WWW.RG-RACING.COM

R&G Racing

Unit 1, Shelley's Lane, East Worldham, Alton, Hampshire, GU34 3AQ

Tel: +44 (0)1420 89007 Fax: +44 (0)1420 87301 www.rg-racing.com Email: info@rg-racing.com



<u>OUTILS REQUIS</u>	<u>VALEURS DE SERRAGE</u>
<ul style="list-style-type: none"> • CLÉ À CLIQUET + DOUILLE 17mm et 19mm. • CLÉ HEXAGONALE • CLÉ DYNAMOMÉTRIQUE (UP TO 50Nm) • CRIC DE SUPPORT APPROPRIÉ. 	M4 BOULON = 8Nm M5 BOULON = 12Nm M6 BOULON = 15Nm M8 BOULON = 20Nm M10 BOULON = 40Nm M12 BOULON = 40Nm

LÉGENDE

ARTICLE NO.	DESCRIPTION	QTÉ
ARTICLE 1	M0714 PLAQUE DE MONTAGE CÔTÉ GAUCHE	1
ARTICLE 2	M0715 PLAQUE DE MONTAGE CÔTÉ DROIT	1
ARTICLE 3	S1430 (36mm ENTRETOISE)	2
ARTICLE 4	S1431 (30mm ENTRETOISE)	2
ARTICLE 5	B0061 PROTECTION CRASH	2
ARTICLE 6	S1340 ENTRETOISE	2
ARTICLE 7	M10x1.50x70mm BOULON	4
ARTICLE 8	M10x1.5x85mm BOULON	2
ARTICLE 9	BC0002 CAPUCHON DE PROTECTION	2
ARTICLE 10	M10 RONDELLE (17mm DIAMÈTRE EXTÉRIEUR)	4
ARTICLE 11	M10 RONDELLE (19mm DIAMÈTRE EXTÉRIEUR)	2
ARTICLE 12	LW0001 M12 RONDELLE ANTI VIBRATION	2
ARTICLE 13	NC0010 M10 CAPUCHONS PLAT	4
ARTICLE 14	S1437 (25mm ENTRETOISE)	
ARTICLE 15	S1438 (40mm ENTRETOISE)	

R&G Racing

Unit 1, Shelley's Lane, East Worldham, Alton, Hampshire, GU34 3AQ

Tel: +44 (0)1420 89007 Fax: +44 (0)1420 87301 www.rg-racing.com Email: info@rg-racing.com



ORIENTATION DE LA PROTECTION CRASH



SCHÉMA D'ENSEMBLE

CÔTÉ GAUCHE

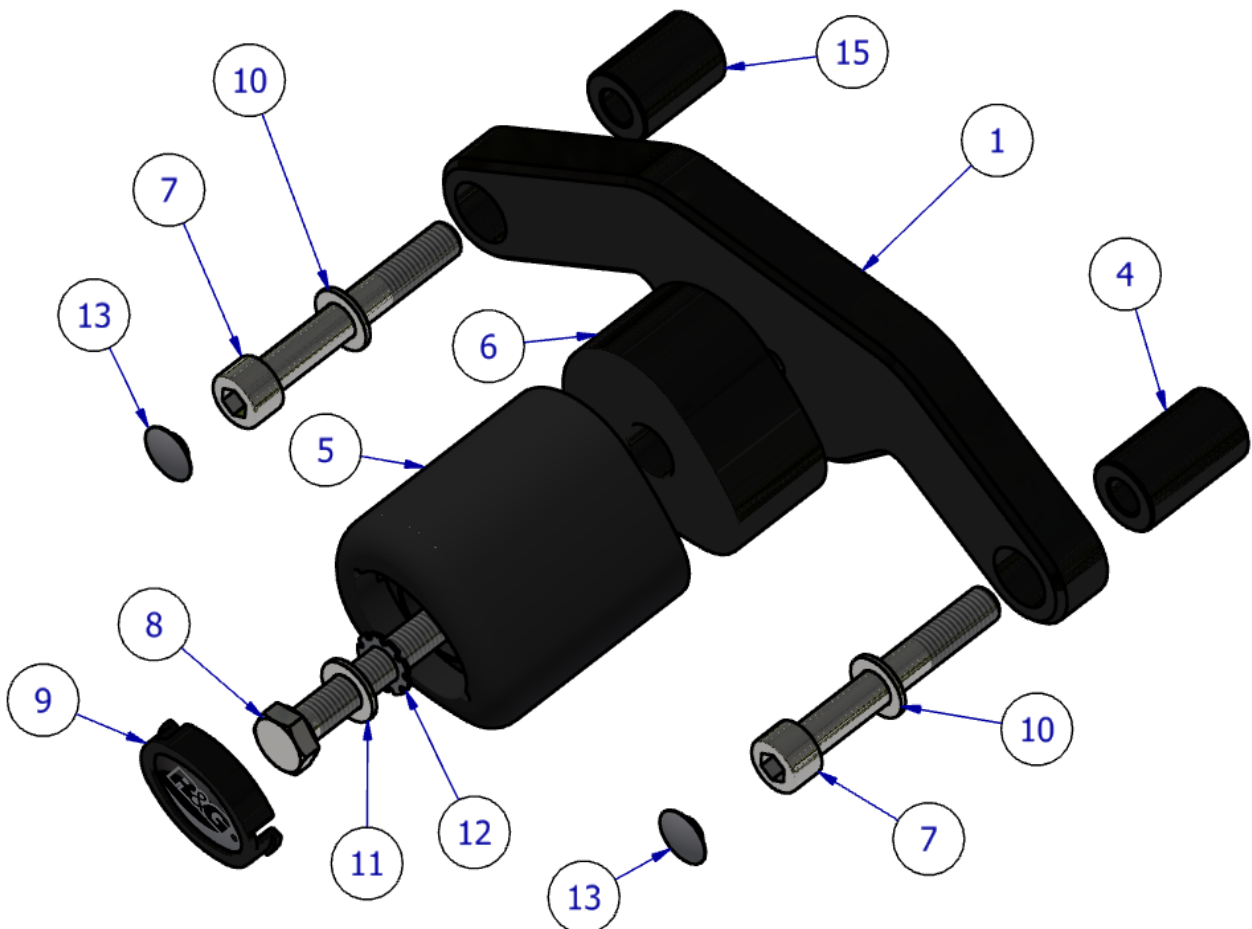

R&G Racing

Unit 1, Shelley's Lane, East Worldham, Alton, Hampshire, GU34 3AQ

Tel: +44 (0)1420 89007 Fax: +44 (0)1420 87301 www.rg-racing.com Email: info@rg-racing.com



CÔTÉ DROIT

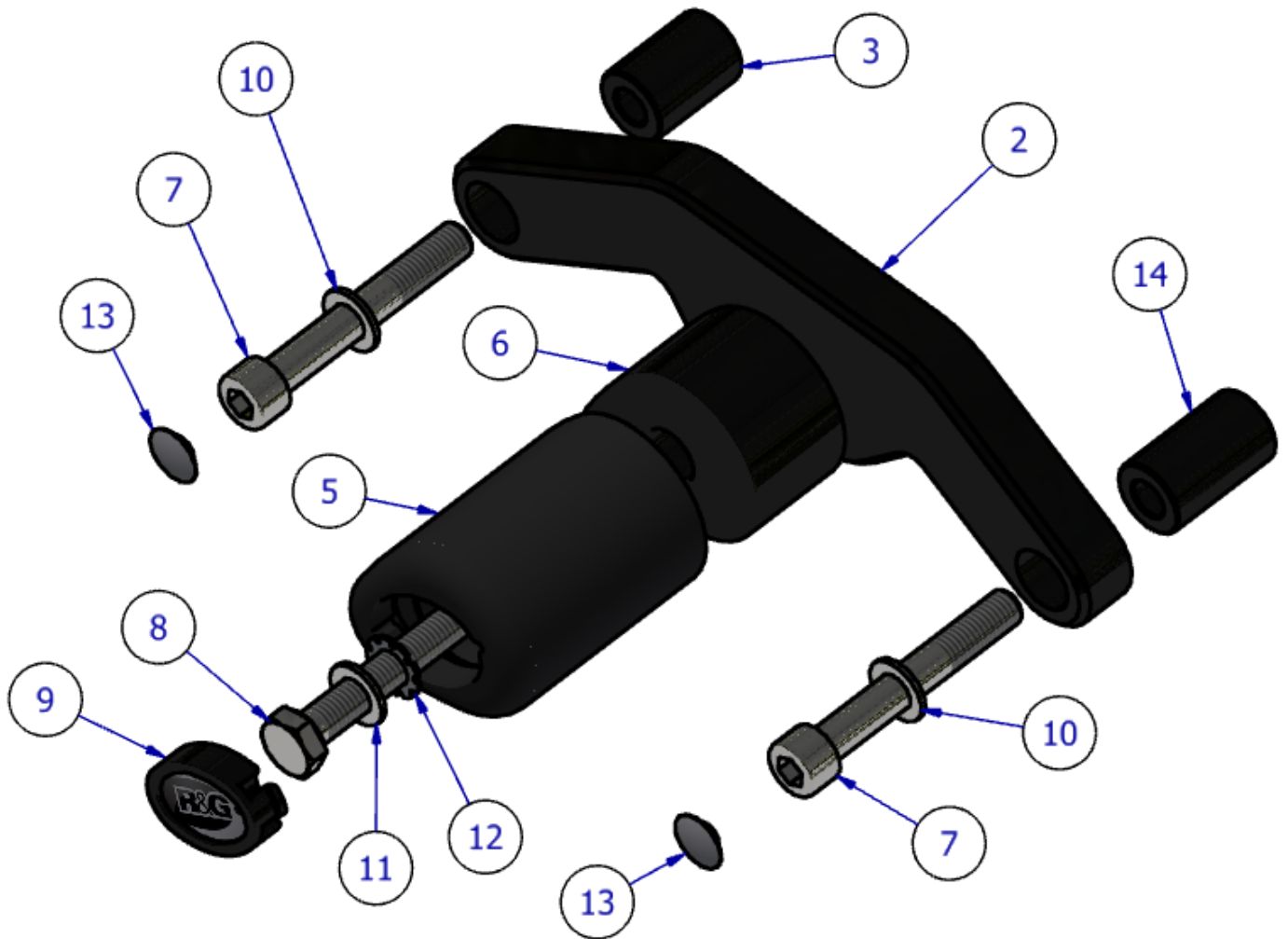
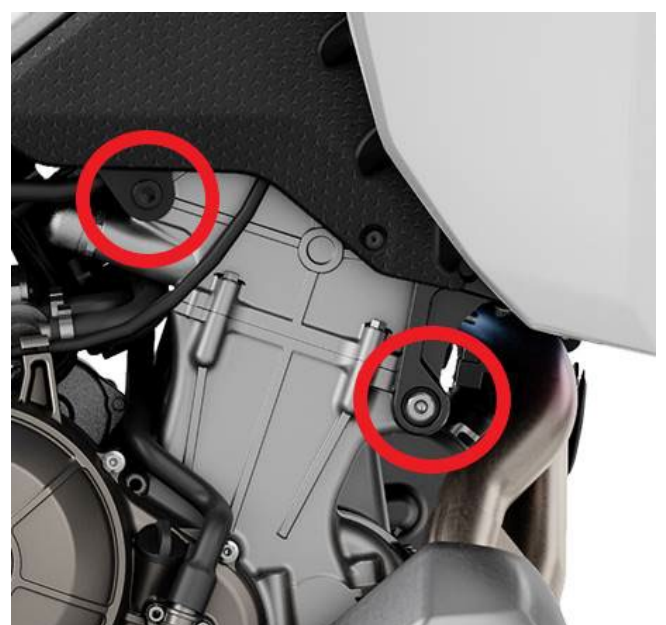
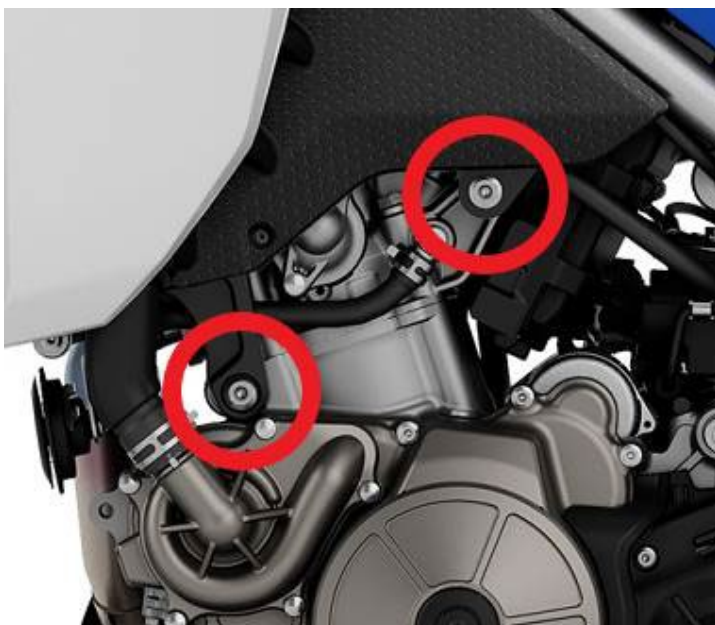

PHOTO 1

PHOTO 2



R&G Racing

Unit 1, Shelley's Lane, East Worldham, Alton, Hampshire, GU34 3AQ

Tel: +44 (0)1420 89007 Fax: +44 (0)1420 87301 www.rg-racing.com Email: info@rg-racing.com



NOTICE DE MONTAGE

Avant de retirer les boulons du moteur, assurez-vous que la moto soit droite et soutenue par un support de moteur approprié ou un cric placé sous le carter de la moto avec un morceau de bois ou de plastique entre le moteur et le cric pour supporter le poids partiel du moteur, cela empêchera le moteur de bouger pendant le montage.

INSTALLATION:

1. Assembler les protections crash, voir la **VUE SCHÉMA D'ENSEMBLE**.
2. Retirez les boulons du moteur d'origine du côté gauche comme indiqué sur la PHOTO 1.
3. Une fois que vous avez retiré les boulons d'origine, placez l'assemblage côté gauche jusqu'aux trous de montage en vous assurant que l'orientation soit correcte comme indiqué ci-dessus à la PAGE 3 (ORIENTATION DE LA PROTECTION CRASH).

Maintenant, serrez à la main la protection crash pour permettre aux filetages des boulons de s'enclencher correctement.

4. Serrez les boulons au couple de serrage correct comme indiqué à la **PAGE 2 (RÉGLAGES DE COUPLE GÉNÉRAUX)**.
5. Une fois que vous avez monté le côté gauche, retirez les boulons du moteur d'origine du côté droit comme indiqué sur la **PHOTO 2**.
6. Une fois que vous avez retiré les boulons d'origine, placez l'ensemble du côté droit sur les trous de montage en vous assurant que l'orientation soit correcte comme indiqué ci-dessus sur la **PAGE 3 (ORIENTATION DE LA PROTECTION CRASH)**.
7. **Répéter l'étape 4 et 5.**
8. Assurez-vous que tous les boulons soient serrés et dans la bonne orientation.
9. S'il n'est pas déjà installé, placez l'autocollant à bulles dans l'évidement du capuchon de protection crash.
10. Monter le capuchon de protection crash dans la protection crash.

ISSUE 2 - 28/10/2022 - JH

CONSUMER NOTICE

The catalogue description and any exhibition of samples are only broad indications of the Products and R&G may make design changes which do not diminish their performance or visual appeal and supplying them in such state shall conform to the order. The Buyer acknowledges no representation or warranty (other than as to title) has been given or will apply to the Products other than those in R&G's order or confirmation and the Buyer confirms it has chosen the Products as being of merchantable quality and suitable for its particular purposes. Where R&G fits the Products or undertakes other services it shall exercise reasonable skill and care and rectify any fault free of charge unless the workmanship has been disturbed. The Buyer is responsible for ensuring that the warranty on the motorcycle is not affected by the fitting of the Products. On return of any defective Products R&G shall at its option either supply a replacement or refund the purchase money but shall not be liable if the Products have been modified or used or maintained otherwise than in accordance with R&G's or manufacturer's instructions and good engineering practice or if the defect arises from accident or neglect. Other than identified above and subject to R&G not limiting its liability for causing death and personal injury, it shall not be liable for indirect or consequential loss and otherwise its liability shall be limited to the amounts paid by the Buyer for the Products or the fitting or service concerned. These terms do not affect the Buyer's statutory rights.

R&G Racing

Unit 1, Shelley's Lane, East Worldham, Alton, Hampshire, GU34 3AQ

Tel: +44 (0)1420 89007 Fax: +44 (0)1420 87301 www.rg-racing.com Email: info@rg-racing.com

**R&G RACING RETURNS POLICY (NON-FAULTY GOODS)**

Returns must be pre-authorized (if not pre-authorized the return will be rejected). Goods may only be returned direct to us if they were purchased direct from us (customer must prove if necessary). Otherwise to be returned to original vendor. Goods must be in re-sellable condition, in the opinion of R&G Racing. All returns are subject to a 25% restocking and handling fee (25% of the gross value exc. P&P – at the prevailing price at time of purchase). The customer must pay any and all carriage charges. No returns of discontinued products, unless within 14 days of purchase. This policy does not affect your statutory rights and does not refer to faulty goods.

R&G Racing

Unit 1, Shelley's Lane, East Worldham, Alton, Hampshire, GU34 3AQ

Tel: +44 (0)1420 89007 Fax: +44 (0)1420 87301 www.rg-racing.com Email: info@rg-racing.com