



FITTING INSTRUCTIONS FOR CLG0040CG/LH FACTORY CARBON LEVER DEFENDER
YAMAHA MT-09 SP 21-



THIS KIT CONTAINS THE ITEMS PICTURED AND LABELLED OVER PAGE.

SOME PARTS MAY BE SHOWN FOR CLARITY OF INSTRUCTIONS ONLY.

DO NOT PROCEED UNTIL YOU ARE SURE ALL PARTS ARE PRESENT.

PLEASE READ ALL INSTRUCTIONS BEFORE PROCEEDING.

**IF IN ANY DOUBT WHEN FITTING OUR PRODUCTS, CONSULT ONE OF OUR DEALERS
OR HAVE FITTED BY A QUALIFIED TECHNICIAN.**

PLEASE NOTE THAT THE WAY THE KIT IS PACKED DOES NOT NECESSARILY REPRESENT THE WAY OF
MOUNTING TO THE BIKE.

IN THE EVENT OF RUBBER WASHERS BEING USED TO HOLD COMPONENTS ONTO BOLTS,
THESE RUBBER WASHERS CAN BE THROWN AWAY.

DIGITAL COPIES OF THESE INSTRUCTIONS ARE AVAILABLE FROM:

WWW.RG-RACING.COM



<u>TOOLS REQUIRED</u>	<u>GENERAL TORQUE SETTINGS</u>
<ul style="list-style-type: none"> • ALLEN TOOL SET TO INCLUDE 4mm A/F SIZE. • SPECIFIC TOOLS REQUIRED TO REMOVE OEM BAR-ENDS, IF APPLICABLE. 	<p>M4 BOLT = 8Nm</p> <p>M5 BOLT = 12Nm</p> <p>M6 BOLT = 15Nm</p> <p>M8 BOLT = 20Nm</p> <p>M10 BOLT = 40Nm</p> <p>M12 BOLT = 40Nm</p>

LEGEND

ITEM NO.	DESCRIPTION	QTY
ITEM 1	CARBON LEVER GUARD (LG0006COMP)	1
ITEM 2	S0781 CONE SPACER	1
ITEM 3	S0928 COUNTERSUNK SPACER	1
ITEM 4	M6x1.00x60mm COUNTERSUNK BOLT	1
ITEM 5	M6x20mm FLAT WASHER	1

EXPLODED ASSEMBLY VIEW

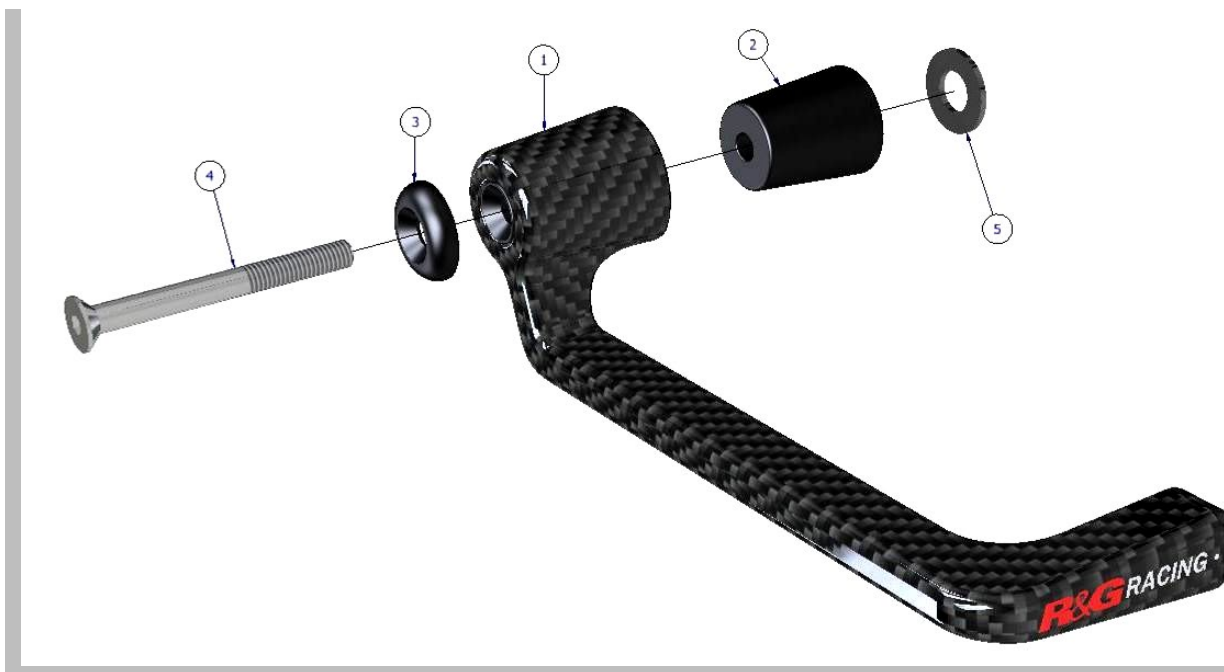

R&G Racing

Unit 1, Shelley's Lane, East Worldham, Alton, Hampshire, GU34 3AQ

Tel: +44 (0)1420 89007 Fax: +44 (0)1420 87301 www.rg-racing.com Email: info@rg-racing.com



FITTING INSTRUCTIONS

- To fit the R&G Carbon Brake Lever Guard, you will need to remove the original bar-end using the specific tools to your bike.
- Place the counter-sunk bolt (**item 4**) through domed counter-sunk spacer (**item 3**) and then through the Lever Guard (**item 1**) so the domed spacer sits against fixed spacer in the Lever Guard.
- Place the large cone spacer (**item 2**) over the thread and into the Lever Guard (the smaller end going in first).
- Locate the washer (**Item 5**) onto the protruded end of the bolt, so the spacer sits against the flat counter-bore surface of the large end of the cone spacer (**item 2**).
- Locate this assembly into the bar and position so when the motorcycle is at full lock in both directions it does not contact any other part of the motorcycle.
- Ensure that the assembled components match the exploded diagram shown in **page 2**.
- Fully tighten the bolt and check throttle & brake operation.

IMPORTANT - WHEN FITTING THIS PRODUCT, IT IS YOUR RESPONSIBILITY TO ENSURE THAT THE PRODUCT IN NO WAY IMPEDES THE OPERATION OF THE MOTORCYCLE AND IS CHECKED REGULARLY FOR TIGHTNESS AND CORRECT OPERATION.

FAILURE TO CHECK THE ABOVE COULD RESULT IN SERIOUS INJURY OR DAMAGE.

ISSUE 1 - 11/01/2022

CONSUMER NOTICE

The catalogue description and any exhibition of samples are only broad indications of the Products and R&G may make design changes which do not diminish their performance or visual appeal and supplying them in such state shall conform to the order. The Buyer acknowledges no representation or warranty (other than as to title) has been given or will apply to the Products other than those in R&G's order or confirmation and the Buyer confirms it has chosen the Products as being of merchantable quality and suitable for its particular purposes. Where R&G fits the Products or undertakes other services it shall exercise reasonable skill and care and rectify any fault free of charge unless the workmanship has been disturbed. The Buyer is responsible for ensuring that the warranty on the motorcycle is not affected by the fitting of the Products. On return of any defective Products R&G shall at its option either supply a replacement or refund the purchase money but shall not be liable if the Products have been modified or used or maintained otherwise than in accordance with R&G's or manufacturer's instructions and good engineering practice or if the defect arises from accident or neglect. Other than identified above and subject to R&G not limiting its liability for causing death and personal injury, it shall not be liable for indirect or consequential loss and otherwise its liability shall be limited to the amounts paid by the Buyer for the Products or the fitting or service concerned. These terms do not affect the Buyer's statutory rights.

R&G RACING RETURNS POLICY (NON-FAULTY GOODS)

Returns must be pre-authorized (if not pre-authorized the return will be rejected). Goods may only be returned direct to us if they were purchased direct from us (customer must prove if necessary). Otherwise to be returned to original vendor. Goods must be in re-sellable condition, in the opinion of R&G Racing. All returns are subject to a 25% restocking and handling fee (25% of the gross value exc. P&P - at the prevailing price at time of purchase). The customer must pay any and all carriage charges. No returns of discontinued products, unless within 14 days of purchase. This policy does not affect your statutory rights and does not refer to faulty goods.

R&G Racing

Unit 1, Shelley's Lane, East Worldham, Alton, Hampshire, GU34 3AQ

Tel: +44 (0)1420 89007 Fax: +44 (0)1420 87301 www.rg-racing.com Email: info@rg-racing.com



INSTRUCTIONS DE MONTAGE POUR CLG0040CG/LH DEFENDER À LEVIER DE CARBONE
D'USINE
YAMAHA MT-09 SP 21-



CE KIT CONTIENT LES ARTICLES ILLUSTRÉS ET ÉTIQUETES SUR LA PAGE.

CERTAINES PARTIES PEUVENT ÊTRE PRÉSENTES UNIQUEMENT POUR LA CLARTE DES INSTRUCTIONS.

NE PAS PROCÉDER AU MONTAGE TANT QUE VOUS N'ÊTES PAS SÛR QUE TOUTES LES PIÈCES SOIENT PRÉSENTES.

VEUILLEZ LIRE TOUTES LES INSTRUCTIONS AVANT DE CONTINUER.

EN CAS DE DOUTE LORS DU MONTAGE DE NOS PRODUITS, CONSULTEZ UN DE NOS REVENEURS OU FAITES APPEL A UN TECHNICIEN QUALIFIÉ.

VEUILLEZ NOTER QUE LA FAÇON DONT LE KIT EST EMBALLÉ NE REPRÉSENTE PAS NECESSAIREMENT LA MANIÈRE DE LE MONTER SUR LA MOTO.

SI DES RONDELLES EN CAOUTCHOUC SONT UTILISÉES POUR MAINTENIR LES COMPOSANTS SUR LES BOULONS, ELLES PEUVENT ÊTRE JETÉES.

NOTICE DISPONIBLE AU TÉLÉCHARGEMENT SUR :

WWW.RG-RACING.COM



<u>OUTILS REQUIS</u>	<u>VALEURS DE SERRAGE</u>
<ul style="list-style-type: none"> CLÉ ALLEN 4mm. OUTILS SPÉCIFIQUES POUR ENLEVER LES EXTRÉMITÉS DE GUION, SI POSSIBLE. 	M4 BOULON = 8Nm M5 BOULON = 12Nm M6 BOULON = 15Nm M8 BOULON = 20Nm M10 BOULON = 40Nm M12 BOULON = 40Nm

LÉGENDE

ARTICLE NO.	DESCRIPTION	QTÉ
ARTICLE 1	PROTECTION POIGNEE EN FIBRE DE CARBONE (LG0006COMP)	1
ARTICLE 2	S0781 ENTRETOISE	1
ARTICLE 3	S0928 ENTRETOISE	1
ARTICLE 4	M6x1.00x60mm BOULON	1
ARTICLE 5	M6x20mm RONDELLE PLATE	1

VUE D'ENSEMBLE



R&G Racing

Unit 1, Shelley's Lane, East Worldham, Alton, Hampshire, GU34 3AQ

Tel: +44 (0)1420 89007 Fax: +44 (0)1420 87301 www.rg-racing.com Email: info@rg-racing.com



NOTICE DE MONTAGE

- Pour monter le protège-levier de frein R&G en carbone, vous devrez retirer l'embout de guidon d'origine à l'aide des outils spécifiques de votre moto.
- Placez le boulon (article 4) à travers l'entretoise fraisée bombée (article 3), puis à travers le protège-levier (article 1) de sorte que l'entretoise bombée repose contre l'entretoise fixe dans le protège-levier.
- Placez la grande entretoise conique (article 2) sur le filetage et dans le protège-levier (la plus petite extrémité entrant en premier).
- Placez la rondelle (article 5) sur l'extrémité saillante du boulon, de sorte que l'entretoise repose contre la surface plate du contre-alésage de la grande extrémité de l'entretoise conique (article 2).
- Placez cet ensemble dans la barre et positionnez-le de sorte que lorsque la moto est complètement verrouillée dans les deux sens, il n'entre en contact avec aucune autre partie de la moto.
- Assurez-vous que les composants assemblés correspondent au schéma éclaté présenté à la page 2.
- Serrez complètement le boulon et vérifiez le fonctionnement de l'accélérateur et des freins.

IMPORTANT - LORS DE L'INSTALLATION DE CE PRODUIT, IL EST DE VOTRE RESPONSABILITÉ DE VOUS ASSURER QUE LE PRODUIT NE PUISSE EN AUCUN CAS ALTÉRER LE FONCTIONNEMENT DE LA MOTO ET DE VÉRIFIER RÉGULIÈREMENT LE SERRAGE ET LE BON FONCTIONNEMENT.

NE PAS VÉRIFIER LES ÉLÉMENTS CI-DESSUS POURRAIT ENTRAÎNER DES BLESSURES OU DES DOMMAGES GRAVES.

ISSUE 1 – 11/01/2022

CONSUMER NOTICE

The catalogue description and any exhibition of samples are only broad indications of the Products and R&G may make design changes which do not diminish their performance or visual appeal and supplying them in such state shall conform to the order. The Buyer acknowledges no representation or warranty (other than as to title) has been given or will apply to the Products other than those in R&G's order or confirmation and the Buyer confirms it has chosen the Products as being of merchantable quality and suitable for its particular purposes. Where R&G fits the Products or undertakes other services it shall exercise reasonable skill and care and rectify any fault free of charge unless the workmanship has been disturbed. The Buyer is responsible for ensuring that the warranty on the motorcycle is not affected by the fitting of the Products. On return of any defective Products R&G shall at its option either supply a replacement or refund the purchase money but shall not be liable if the Products have been modified or used or maintained otherwise than in accordance with R&G's or manufacturer's instructions and good engineering practice or if the defect arises from accident or neglect. Other than identified above and subject to R&G not limiting its liability for causing death and personal injury, it shall not be liable for indirect or consequential loss and otherwise its liability shall be limited to the amounts paid by the Buyer for the Products or the fitting or service concerned. These terms do not affect the Buyer's statutory rights.

R&G RACING RETURNS POLICY (NON-FAULTY GOODS)

Returns must be pre-authorized (if not pre-authorized the return will be rejected). Goods may only be returned direct to us if they were purchased direct from us (customer must prove if necessary). Otherwise to be returned to original vendor. Goods must be in re-sellable condition, in the opinion of R&G Racing. All returns are subject to a 25% restocking and handling fee (25% of the gross value exc. P&P – at the prevailing price at time of purchase). The customer must pay any and all carriage charges. No returns of discontinued products, unless within 14 days of purchase. This policy does not affect your statutory rights and does not refer to faulty goods.

R&G Racing

Unit 1, Shelley's Lane, East Worldham, Alton, Hampshire, GU34 3AQ

Tel: +44 (0)1420 89007 Fax: +44 (0)1420 87301 www.rg-racing.com Email: info@rg-racing.com



FITTING INSTRUCTIONS FOR CLG0040CG/RH FACTORY CARBON LEVER DEFENDER
YAMAHA MT-09 SP 21-



THIS KIT CONTAINS THE ITEMS PICTURED AND LABELLED OVER PAGE.

SOME PARTS MAY BE SHOWN FOR CLARITY OF INSTRUCTIONS ONLY.

DO NOT PROCEED UNTIL YOU ARE SURE ALL PARTS ARE PRESENT.

PLEASE READ ALL INSTRUCTIONS BEFORE PROCEEDING.

**IF IN ANY DOUBT WHEN FITTING OUR PRODUCTS, CONSULT ONE OF OUR DEALERS
OR HAVE FITTED BY A QUALIFIED TECHNICIAN.**

PLEASE NOTE THAT THE WAY THE KIT IS PACKED DOES NOT NECESSARILY REPRESENT THE WAY OF
MOUNTING TO THE BIKE.

IN THE EVENT OF RUBBER WASHERS BEING USED TO HOLD COMPONENTS ONTO BOLTS,
THESE RUBBER WASHERS CAN BE THROWN AWAY.

DIGITAL COPIES OF THESE INSTRUCTIONS ARE AVAILABLE FROM:

WWW.RG-RACING.COM



<u>TOOLS REQUIRED</u>	<u>GENERAL TORQUE SETTINGS</u>
<ul style="list-style-type: none"> • ALLEN TOOL SET TO INCLUDE 4mm A/F SIZE. • SPECIFIC TOOLS REQUIRED TO REMOVE OEM BAR-ENDS, IF APPLICABLE. 	<p>M4 BOLT = 8Nm</p> <p>M5 BOLT = 12Nm</p> <p>M6 BOLT = 15Nm</p> <p>M8 BOLT = 20Nm</p> <p>M10 BOLT = 40Nm</p> <p>M12 BOLT = 40Nm</p>

LEGEND

ITEM NO.	DESCRIPTION	QTY
ITEM 1	CARBON LEVER GUARD (LG0005COMP)	1
ITEM 2	S0781 CONE SPACER	1
ITEM 3	S0928 COUNTERSUNK SPACER	1
ITEM 4	M6x1.00x60mm COUNTERSUNK BOLT	1
ITEM 5	M6x20mm FLAT WASHER	1

EXPLODED ASSEMBLY VIEW

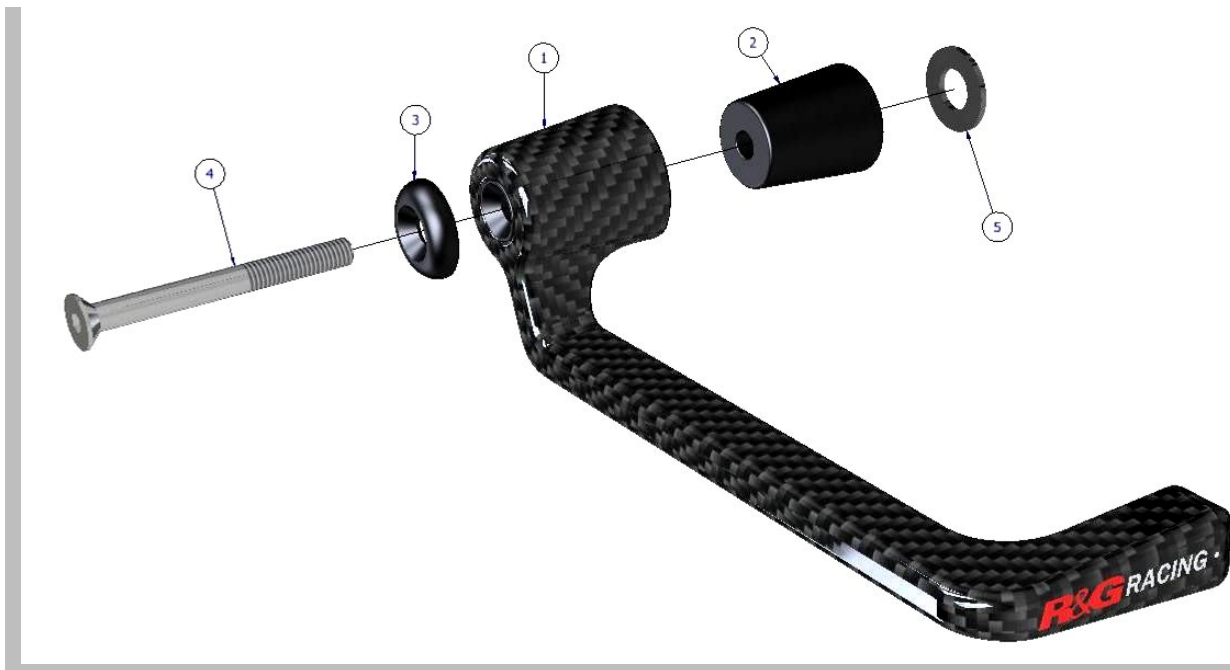

R&G Racing

Unit 1, Shelley's Lane, East Worldham, Alton, Hampshire, GU34 3AQ

Tel: +44 (0)1420 89007 Fax: +44 (0)1420 87301 www.rg-racing.com Email: info@rg-racing.com



FITTING INSTRUCTIONS

- To fit the R&G Carbon Brake Lever Guard, you will need to remove the original bar-end using the specific tools to your bike.
- Place the counter-sunk bolt (**item 4**) through domed counter-sunk spacer (**item 3**) and then through the Lever Guard (**item 1**) so the domed spacer sits against fixed spacer in the Lever Guard.
- Place the large cone spacer (**item 2**) over the thread and into the Lever Guard (the smaller end going in first).
- Locate the washer (**Item 5**) onto the protruded end of the bolt, so the spacer sits against the flat counter-bore surface of the large end of the cone spacer (**item 2**).
- Locate this assembly into the bar and position so when the motorcycle is at full lock in both directions it does not contact any other part of the motorcycle.
- Ensure that the assembled components match the exploded diagram shown in **page 2**.
- Fully tighten the bolt and check throttle & brake operation.

IMPORTANT - WHEN FITTING THIS PRODUCT, IT IS YOUR RESPONSIBILITY TO ENSURE THAT THE PRODUCT IN NO WAY IMPEDES THE OPERATION OF THE MOTORCYCLE AND IS CHECKED REGULARLY FOR TIGHTNESS AND CORRECT OPERATION.

FAILURE TO CHECK THE ABOVE COULD RESULT IN SERIOUS INJURY OR DAMAGE.

ISSUE 1 - 11/01/2022

CONSUMER NOTICE

The catalogue description and any exhibition of samples are only broad indications of the Products and R&G may make design changes which do not diminish their performance or visual appeal and supplying them in such state shall conform to the order. The Buyer acknowledges no representation or warranty (other than as to title) has been given or will apply to the Products other than those in R&G's order or confirmation and the Buyer confirms it has chosen the Products as being of merchantable quality and suitable for its particular purposes. Where R&G fits the Products or undertakes other services it shall exercise reasonable skill and care and rectify any fault free of charge unless the workmanship has been disturbed. The Buyer is responsible for ensuring that the warranty on the motorcycle is not affected by the fitting of the Products. On return of any defective Products R&G shall at its option either supply a replacement or refund the purchase money but shall not be liable if the Products have been modified or used or maintained otherwise than in accordance with R&G's or manufacturer's instructions and good engineering practice or if the defect arises from accident or neglect. Other than identified above and subject to R&G not limiting its liability for causing death and personal injury, it shall not be liable for indirect or consequential loss and otherwise its liability shall be limited to the amounts paid by the Buyer for the Products or the fitting or service concerned. These terms do not affect the Buyer's statutory rights.

R&G RACING RETURNS POLICY (NON-FAULTY GOODS)

Returns must be pre-authorized (if not pre-authorized the return will be rejected). Goods may only be returned direct to us if they were purchased direct from us (customer must prove if necessary). Otherwise to be returned to original vendor. Goods must be in re-sellable condition, in the opinion of R&G Racing. All returns are subject to a 25% restocking and handling fee (25% of the gross value exc. P&P - at the prevailing price at time of purchase). The customer must pay any and all carriage charges. No returns of discontinued products, unless within 14 days of purchase. This policy does not affect your statutory rights and does not refer to faulty goods.

R&G Racing

Unit 1, Shelley's Lane, East Worldham, Alton, Hampshire, GU34 3AQ

Tel: +44 (0)1420 89007 Fax: +44 (0)1420 87301 www.rg-racing.com Email: info@rg-racing.com



INSTRUCTIONS DE MONTAGE POUR CLG0040CG/RH DEFENDER À LEVIER DE CARBONE
D'USINE
YAMAHA MT-09 SP 21-



CE KIT CONTIENT LES ARTICLES ILLUSTRÉS ET ÉTIQUETES SUR LA PAGE.

CERTAINES PARTIES PEUVENT ÊTRE PRÉSENTES UNIQUEMENT POUR LA CLARTÉ DES INSTRUCTIONS.

NE PAS PROCÉDER AU MONTAGE TANT QUE VOUS N'ÊTES PAS SÛR QUE TOUTES LES PIÈCES SOIENT PRÉSENTES.

VEUILLEZ LIRE TOUTES LES INSTRUCTIONS AVANT DE CONTINUER.

EN CAS DE DOUTE LORS DU MONTAGE DE NOS PRODUITS, CONSULTEZ UN DE NOS REVENDEURS OU FAITES APPEL À UN TECHNICIEN QUALIFIÉ.

VEUILLEZ NOTER QUE LA FAÇON DONT LE KIT EST EMBALLÉ NE REPRÉSENTE PAS NECESSAIREMENT LA MANIÈRE DE LE MONTER SUR LA MOTO.

SI DES RONDELLES EN CAOUTCHOUC SONT UTILISÉES POUR MAINTENIR LES COMPOSANTS SUR LES BOULONS, ELLES PEUVENT ÊTRE JETÉES.

NOTICE DISPONIBLE AU TÉLÉCHARGEMENT SUR :

WWW.RG-RACING.COM



<u>OUTILS REQUIS</u>	<u>VALEURS DE SERRAGE</u>
<ul style="list-style-type: none"> • CLÉ ALLEN 4mm. • OUTILS SPÉCIFIQUES POUR ENLEVER LES EXTRÉMITÉS DE GUION, SI POSSIBLE. 	M4 BOULON = 8Nm M5 BOULON = 12Nm M6 BOULON = 15Nm M8 BOULON = 20Nm M10 BOULON = 40Nm M12 BOULON = 40Nm

LÉGENDE

ARTICLE NO.	DESCRIPTION	QTÉ
ARTICLE 1	PROTECTION POIGNEE EN FIBRE DE CARBONE (LG0005COMP)	1
ARTICLE 2	S0781 ENTRETOISE	1
ARTICLE 3	S0928 ENTRETOISE	1
ARTICLE 4	M6x1.00x60mm BOULON	1
ARTICLE 5	M6x20mm RONDELLE PLATE	1

VUE D'ENSEMBLE

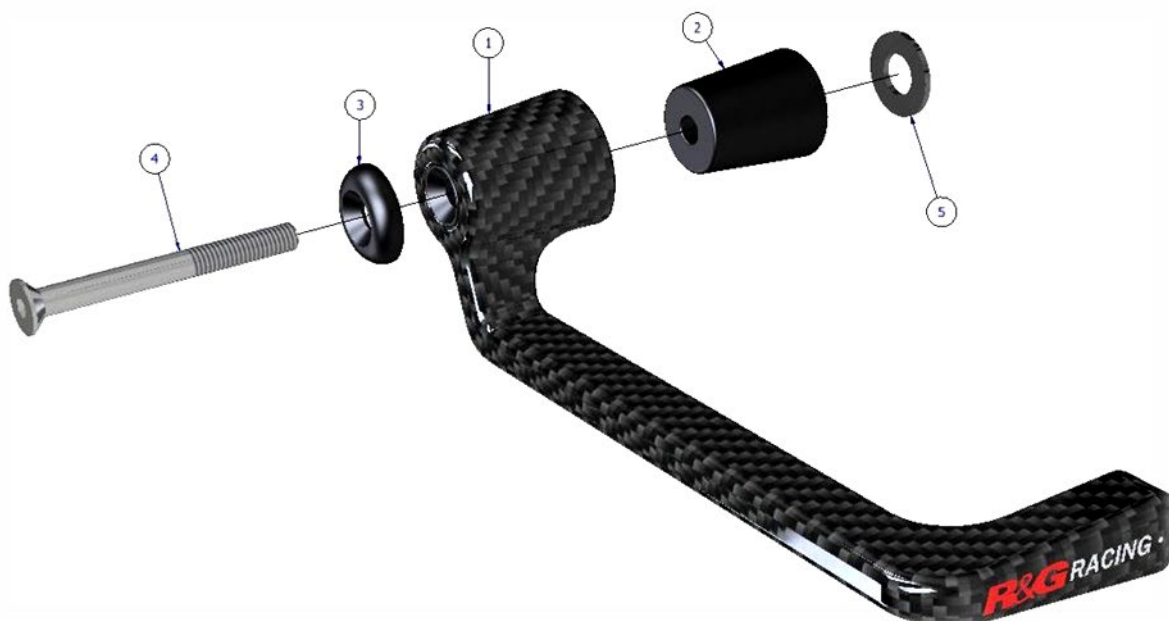



NOTICE DE MONTAGE

- Pour monter le protège-levier de frein R&G en carbone, vous devrez retirer l'embout de guidon d'origine à l'aide des outils spécifiques de votre moto.
- Placez le boulon (article 4) à travers l'entretoise fraisée bombée (article 3), puis à travers le protège-levier (article 1) de sorte que l'entretoise bombée repose contre l'entretoise fixe dans le protège-levier.
- Placez la grande entretoise conique (article 2) sur le filetage et dans le protège-levier (la plus petite extrémité entrant en premier).
- Placez la rondelle (article 5) sur l'extrémité saillante du boulon, de sorte que l'entretoise repose contre la surface plate du contre-alésage de la grande extrémité de l'entretoise conique (article 2).
- Placez cet ensemble dans la barre et positionnez-le de sorte que lorsque la moto est complètement verrouillée dans les deux sens, il n'entre en contact avec aucune autre partie de la moto.
- Assurez-vous que les composants assemblés correspondent au schéma éclaté présenté à la page 2.
- Serrez complètement le boulon et vérifiez le fonctionnement de l'accélérateur et des freins.

IMPORTANT - LORS DE L'INSTALLATION DE CE PRODUIT, IL EST DE VOTRE RESPONSABILITÉ DE VOUS ASSURER QUE LE PRODUIT NE PUISSE EN AUCUN CAS ALTÉRER LE FONCTIONNEMENT DE LA MOTO ET DE VÉRIFIER RÉGULIÈREMENT LE SERRAGE ET LE BON FONCTIONNEMENT.

NE PAS VÉRIFIER LES ÉLÉMENTS CI-DESSUS POURRAIT ENTRAÎNER DES BLESSURES OU DES DOMMAGES GRAVES.

ISSUE 1 – 11/01/2022

CONSUMER NOTICE

The catalogue description and any exhibition of samples are only broad indications of the Products and R&G may make design changes which do not diminish their performance or visual appeal and supplying them in such state shall conform to the order. The Buyer acknowledges no representation or warranty (other than as to title) has been given or will apply to the Products other than those in R&G's order or confirmation and the Buyer confirms it has chosen the Products as being of merchantable quality and suitable for its particular purposes. Where R&G fits the Products or undertakes other services it shall exercise reasonable skill and care and rectify any fault free of charge unless the workmanship has been disturbed. The Buyer is responsible for ensuring that the warranty on the motorcycle is not affected by the fitting of the Products. On return of any defective Products R&G shall at its option either supply a replacement or refund the purchase money but shall not be liable if the Products have been modified or used or maintained otherwise than in accordance with R&G's or manufacturer's instructions and good engineering practice or if the defect arises from accident or neglect. Other than identified above and subject to R&G not limiting its liability for causing death and personal injury, it shall not be liable for indirect or consequential loss and otherwise its liability shall be limited to the amounts paid by the Buyer for the Products or the fitting or service concerned. These terms do not affect the Buyer's statutory rights.

R&G RACING RETURNS POLICY (NON-FAULTY GOODS)

Returns must be pre-authorized (if not pre-authorized the return will be rejected). Goods may only be returned direct to us if they were purchased direct from us (customer must prove if necessary). Otherwise to be returned to original vendor. Goods must be in re-sellable condition, in the opinion of R&G Racing. All returns are subject to a 25% restocking and handling fee (25% of the gross value exc. P&P – at the prevailing price at time of purchase). The customer must pay any and all carriage charges. No returns of discontinued products, unless within 14 days of purchase. This policy does not affect your statutory rights and does not refer to faulty goods.

R&G Racing

Unit 1, Shelley's Lane, East Worldham, Alton, Hampshire, GU34 3AQ

Tel: +44 (0)1420 89007 Fax: +44 (0)1420 87301 www.rg-racing.com Email: info@rg-racing.com