

**Note!**

These mounting instructions are for the below versions of HD 044

Product Number	Fitted Spring
HD 044	66422-026 (B)
HD 044S2	66422-028 (B)
HD 044S3	66422-030 (B)

**Note!**

Please note that this image is a general representation of the product and may differ slightly from your product.

**Note!**

Please note that during storage and transportation, especially at high ambient temperature, some of the oil and grease used for assembling may leak and stain the packaging. This is in no way detrimental to the product, wipe off the excessive oil/grease with a cloth.

**Kit Contents**

Description	Part No	Pcs
Shock absorber	HD044	2
Sleeve	00123-17	4
Washer 8,4/16/1,5	00153-04	8
Tie-rap 200x4,8	00231-01	2
Nut M6	00430-02	4
Washer stainless	03118-08	4
Tool preload adjuster	03199-01	1
Owner's manual	07241-02	1
Bracket HD LH	21157-02	2
Bracket	03102-05	2
Screw M6x14	00382-16	2
Screw M6x10	01046-60	4
Screw M6x20	01046-16	4
Screw M6x16	01046-01	4
Reservoir bracket	U00365-01	2
Reservoir adapter plate	U00366-01	2
Button head 5/16" x 1-3/4"	U00367-01	4
Spacer - short	U00368-12	2
Spacer - long	U00368-21	2
Sticker set "ÖHLINS"		

**Note!**

Before installing this product, check the contents of the kit. If anything is missing, please contact an Öhlins dealer.

**Warning!**

Before installing this product, read the Öhlins Owner's Manual. The shock absorber/front fork/steering damper is an important part of your vehicle and will affect the stability.

**Shock absorber for Harley Davidson Touring**

**HD 044 /S2 /S3**

**Mounting Instructions**



# MOUNTING INSTRUCTIONS

## **⚠ Warning!**

*It is advisable to have an Öhlins dealer install the shock absorber/front fork/steering damper.*

## **⚠ Warning!**

*If working on a raised vehicle, ensure it is securely supported so that it will not tip.*

## **📌 Note!**

*Before mounting this product clean the vehicle thoroughly.*

## **📌 Note!**

*When working on this product, always see the Vehicle Service Manual for vehicle specific procedures and important data.*

**1**

Put the motorcycle on a workstand so that the rear wheel barely touches the ground.

**2**

Remove the original shock absorber.

**3**

Use the sleeves (00123-17) and washers (03118-08) in the end eye according to the figure.

## **📌 Note!**

*If the swingarm/frame and/or aftermarket accessories cause misalignment, use washer(s) (03118-08).*

## **👁 Note!**

*Lower the vehicle so that the suspension is slightly compressed before tightening the screws.*

## **👉 Caution!**

*Ensure that all screws are tightened to the correct torque and that nothing fouls or restricts movement of the shock absorber when the suspension is fully compressed or extended.*

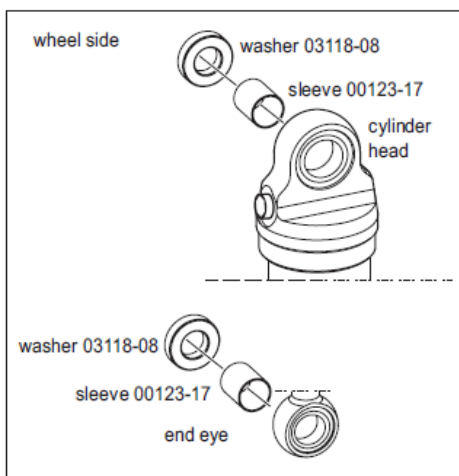

# MOUNTING INSTRUCTIONS TO CONCEAL RESERVOIRS

Left Side

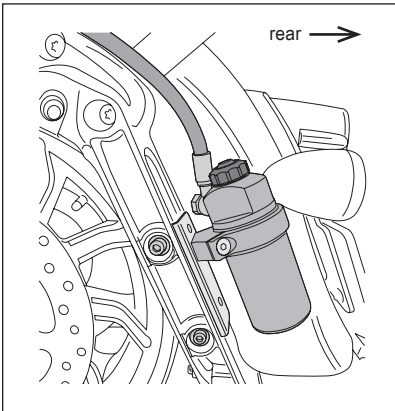
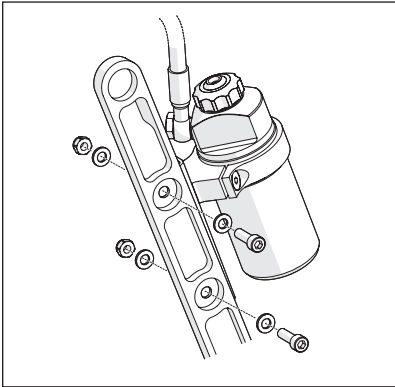
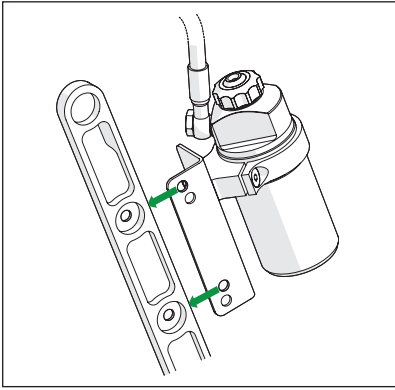

Right Side

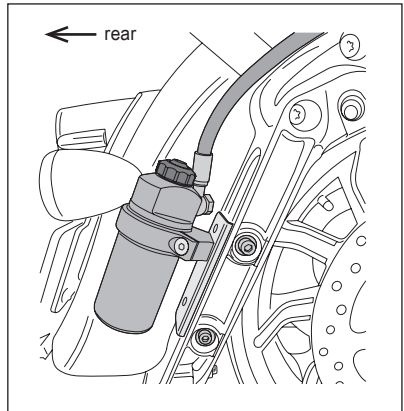
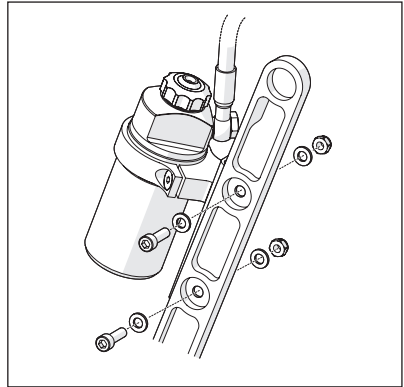
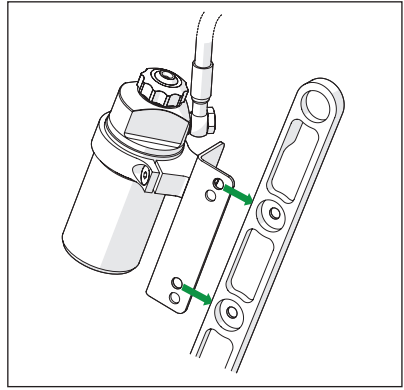

# MOUNTING INSTRUCTIONS TO EXPOSE RESERVOIRS

1.

After shocks are installed, remove the 2 OEM bolts from the saddle bag support frame.

2.

Pre-assemble the reservoir brackets

- a. Attach supplied adapter plate (U00366-01) to bracket (U00365-01) with the provided M6x10 bolts (01046-60). Use blue Loctite 242 on bolts before threading them through the counter-bored holes in the adapter plate.
- b. Attach gold reservoir bracket (03102-05) to the adapter plate with the M6x16 bolts (01046-01). Use blue Loctite 242 on bolts.

**Note!**

*the orientation of the pinch bolt cavity of bracket 03102-05 will determine the side of the bike the assembly will be installed on. Make sure to flip this bracket when building the assembly for the opposite side to have a designated left and right side once you're done. The pinch bolts will always face towards the center of the bike if assemblies are installed and built properly.*

- c. With some blue Loctite 242, Loosely install the pinch bolt (00382-16) into the reservoir bracket.

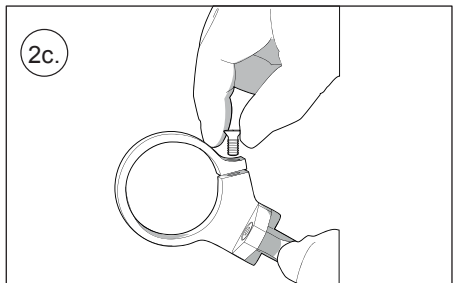
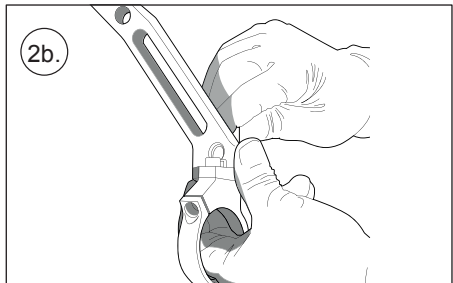
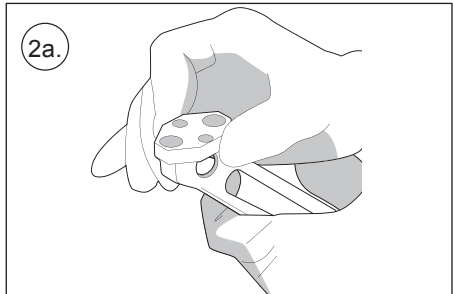
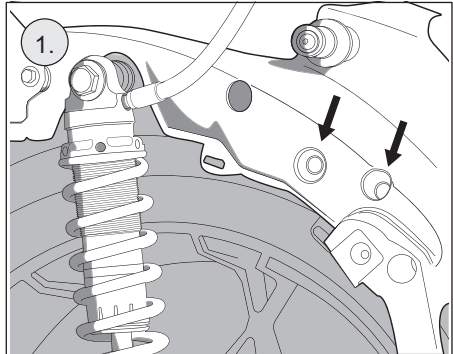

# MOUNTING INSTRUCTIONS TO EXPOSE RESERVOIRS

## 3.

Installing the reservoir bracket assemblies

- a. Install reservoir into the bracket but do not tighten the pinch bolt yet.
- b. Reservoir bracket assemblies should be installed as shown below, with the pinch bolt oriented towards the inside of the bike.
- c. Install bracket assembly to saddle bag support frame using 1 short spacer (U00368-12) towards the front of the bike and 1 long spacer (U00368-21) towards the rear. Use 2 of the 1-3/4" long button head screws (U00367-01) to fasten onto frame using blue Loctite 242.

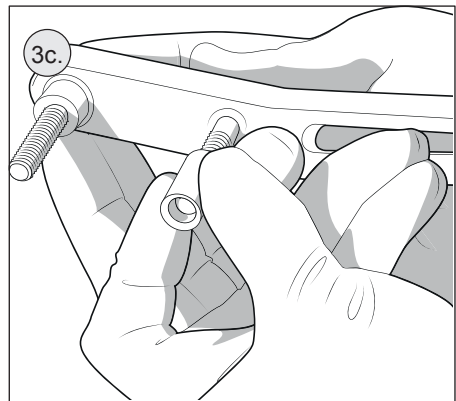
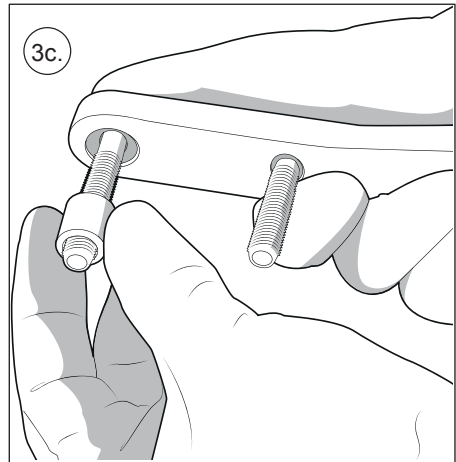
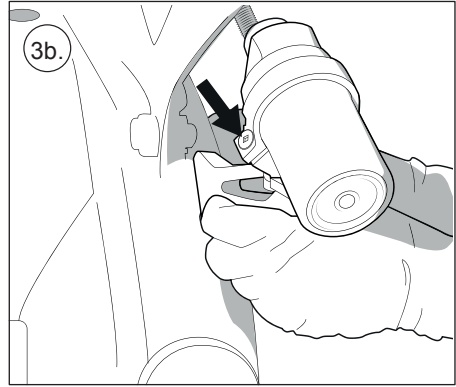

# MOUNTING INSTRUCTIONS TO EXPOSE RESERVOIRS

- d. Clock the reservoir in the reservoir bracket so that the head of the banjo bolt is oriented towards the damper, and that the clamping surface on the reservoir is centered in the clamp, then tighten the pinch bolt to finish installation on this side.
- e. Repeat process for the other side.

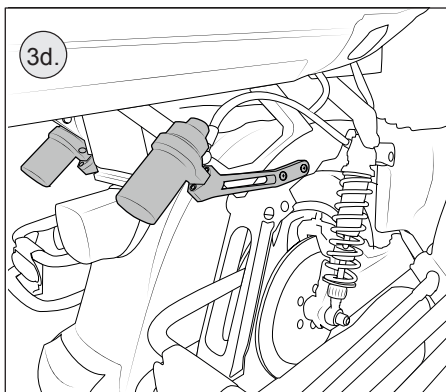
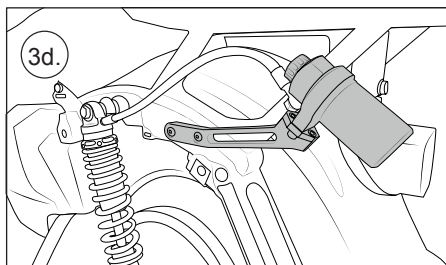
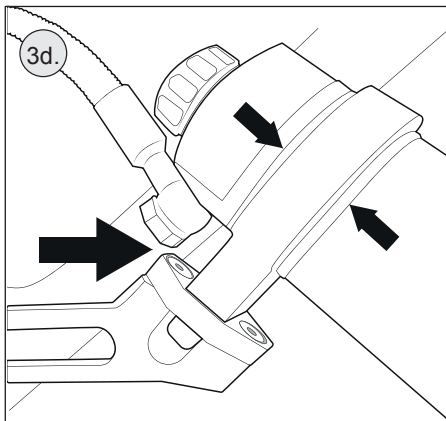

# REBOUND ADJUSTMENT

Starting rebound clicker position is 14 clicks out from closed

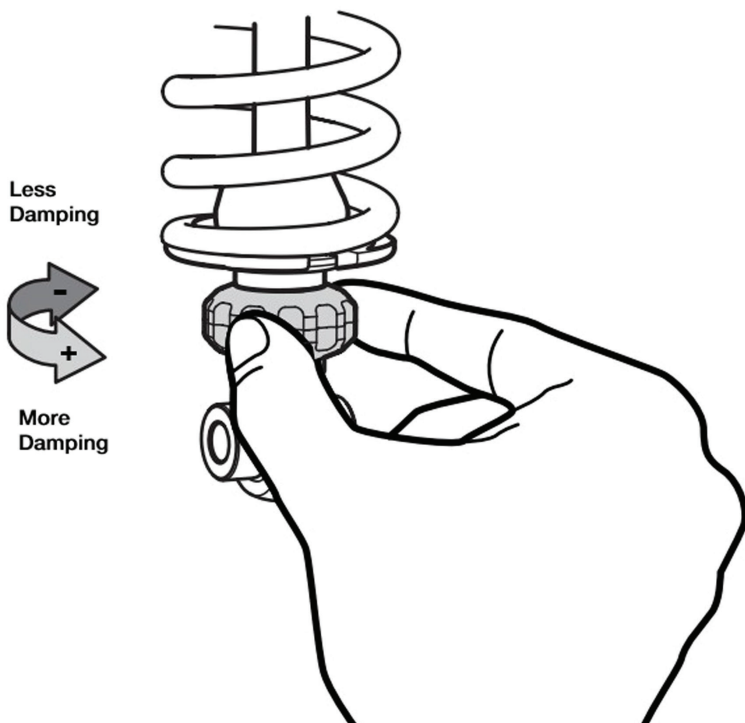

To check it's set correctly, turn in clockwise in the direction of + arrow until it stops, then open 14 clicks. This should be your starting position for rebound. If you want more damping / slower movement, close the rebound in the + direction. If you want less damping / more movement, open the rebound in the - direction.

## **Note!**

*Best operating range is 10 – 18 clicks out.*

# COMPRESSION ADJUSTMENT

## Starting compression clicker position is 14 clicks out from closed

Compression damping controls the energy absorption when the shock absorber is being compressed, thus controls how easy the shock absorber compresses when the rear wheel is being loaded or hits a bump.

Adjust by turning the knob on top of the reservoir. Turn clockwise to increase damping, turn counter clockwise to decrease.

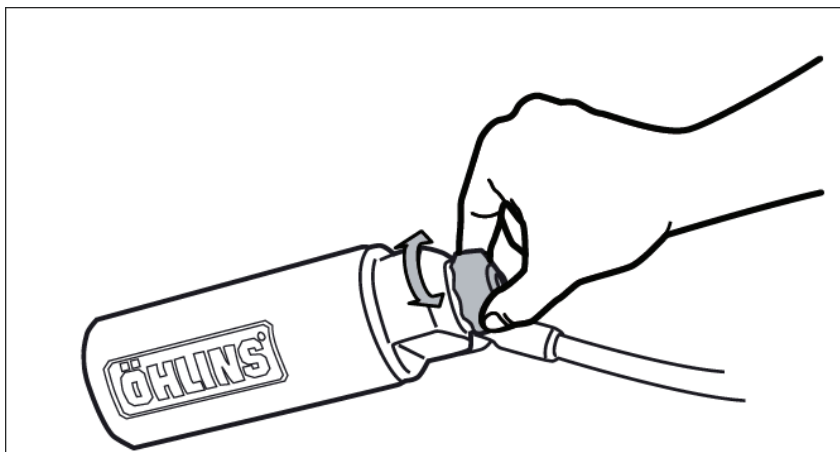

To check it's set correctly, turn in clockwise in the direction of + arrow until it stops, then open 14 clicks. This should be your starting position for Compression. If you want more damping / slower movement, close the compression adjuster clockwise. If you want less damping / more movement, open the compression adjuster counter-clockwise.

### **Note!**

*Best operating range is 10 – 18 clicks out.*



# LENGTH ADJUSTMENT

## Length adjustment:

By adjusting the length of the shock absorber the steering geometry as well as the chain force can be changed.

A shorter shock absorber will result in a lower motorcycle. The fork angle as well as the trail will increase and normally the chain force will be reduced with less anti-squat as a result.

A slight change of center of gravity is another result of changing the length.

A longer shock absorber will result in a higher motorcycle. The fork angle and trail will decrease and normally the chain force will increase with more anti-squat as a result.

**To Adjust Length:** We recommend to remove the shock absorber from the vehicle before adjusting the length. Use two 19 or 24 mm wrenches. Hold the upper nut with one hand and at the same time loosen the lock nut (lower nut). Turn the end eye / bracket to the desired length. Please make sure to measure the ride height before and after adjusting the length.

**Tightening torque: 19mm wrench 30Nm**

**Tightening torque: 24mm wrench 40Nm**

## **⚠ Warning!**

Remember to lock the lock nut after adjusting the length.

## **👁 Note!**

After adjusting the length, check the head light angle of your vehicle.

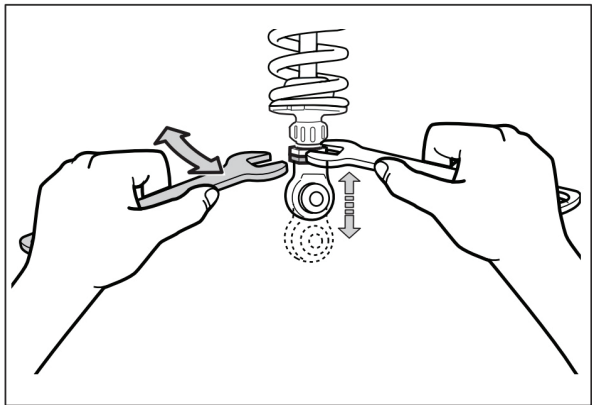
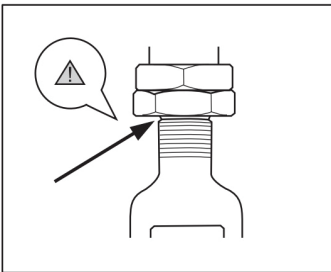

## **⚠ Warning!**

The adjustable end eye/bracket must not be threaded out more than that the groove is fully visible beneath the lock nut. This is maximum length. After adjusting, make sure that the lock nut is tightened.

# SETUP SPRING CALCULATOR

Go to "www.ohlinsusa.com", under "Product Search", type HD 044. Once on landing page, select "Setup Calculator"

## HD 044 Harley S36 Twin Shocks

OVERVIEW

IMAGES

TECH

SETUP CALCULATOR

SERVICE

*\*Once you get to the spring calculator, enter all the details about your bike and your weights.*

### Note!

• You have the option to change from lbs to kgs.

### SETUP CALCULATOR

#### About Your Bike

Model / Year

1990 - 2020 Harley-Davidson Ultra Class ▾

Tour Pack

YES

NO

Primary Use

Solo no luggage ▾

#### About The Rider

[lbs](#) | [kgs](#)

Rider Weight  
(including gear)

lbs

Passenger Weight  
(including gear)

0

lbs

Weight in Saddlebags

0

lbs

[New Setup](#) | [Returning Setup](#)

• Once you have entered the correct weights, choose "Returning Setup" so it gives you an option to select the springs installed on your shocks.

# SETUP SPRING CALCULATOR

**Note!**

\*Make sure to double check the springs installed on your shocks as the distributor may have changed to accommodate your weight scenarios

Best Fit ▼

Best Fit

66420-026 (26 N/mm)

66420-028 (28 N/mm)

66420-030 (30 N/mm)

00280-21 (25 N/mm) Legacy

00180-97 (27 N/mm) Legacy

00180-22 (29 N/mm) Legacy

21180-01 (32 N/mm) Legacy

6. Once you click "Calculate", the setup data will be displayed. Example below:

CALCULATE

Rider Scenario	Spring Position	Comfort		SETUP DETAILS
		Soft	Firm	
Solo	26 (mm)			SETUP DETAILS
Solo With Luggage	26 (mm)			SETUP DETAILS
Two Up	26 (mm)			SETUP DETAILS
Two Up With Luggage	26 (mm)			SETUP DETAILS

7. The "Spring Position" will tell you in millimeter the distance the preload collar should be from the bottom of the cylinder head for each scenario with your primary use highlighted in Gold.

You can click "Setup Details" for an image describing further. There's "Setup Details" beside all (4) rider scenarios (Solo, Solo with Luggage, Two Up and Two Up with Luggage Make sure to click the one you plan to set the bike up for.

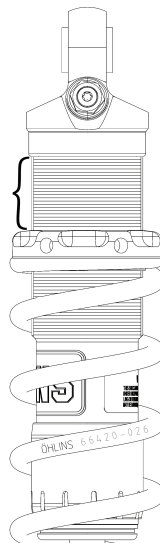

## SPRING POSITION

---

👁️ Öhlins products are subject to continuous improvement and development, therefore, although these instructions include the most up-to-date information available at the time of printing, minor updates may occur.

© Öhlins USA Co. Ltd. All rights reserved. Any reprinting or unauthorized use without the written permission of Öhlins Racing AB is prohibited.

Öhlins USA. Ltd  
703 South Grove Street,  
Hendersonville NC, 28972



[www.ohlins.com](http://www.ohlins.com)