

MOTORSCHUTZBÜGEL/ ENGINE GUARD

MOTO GUZZI Stelvio

(2024-)

Art.Nr./Item-no.:

501560 00 01 schwarz/black



Inhalt

1x 700013944 Motorschutzbügel links
1x 700013945 Motorschutzbügel rechts
1x 700013947 Schraubensatz:

1	700013946 Hupenhalter
4	Zylinderschraube M10x40
2	Zylinderschraube M8x110
2	Sechskantschraube M8x40
4	U- Scheibe Ø10,5
4	U- Scheibe Ø8,4
4	Aludistanz Ø20xØ11x15
2	Aludistanz Ø15xØ9x10
1	Stahldistanz Ø18xØ9x82 schwarz
1	Stahldistanz Ø18xØ9x90 schwarz

Content

1x 700013944 Engine guard left
1x 700013945 Engine guard right
1x 700013947 Screw kit:

1	700013946 Horn holder
4	Allen screw M10x40
2	Allen screw M8x110
2	Hexagon bolt M8x40
4	Washer Ø10,5
4	Washer Ø8,4
4	Alu spacer Ø20xØ11x15
2	Alu spacer Ø15xØ9x10
1	Steel spacer Ø18xØ9x82 black
1	Steel spacer Ø18xØ9x90 black

Benötigte Werkzeuge / Required tools

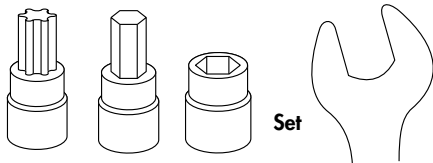

Set

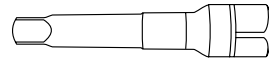

Verlängerung/extension

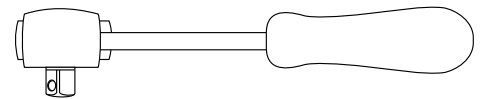

Ratsche/Ratchet

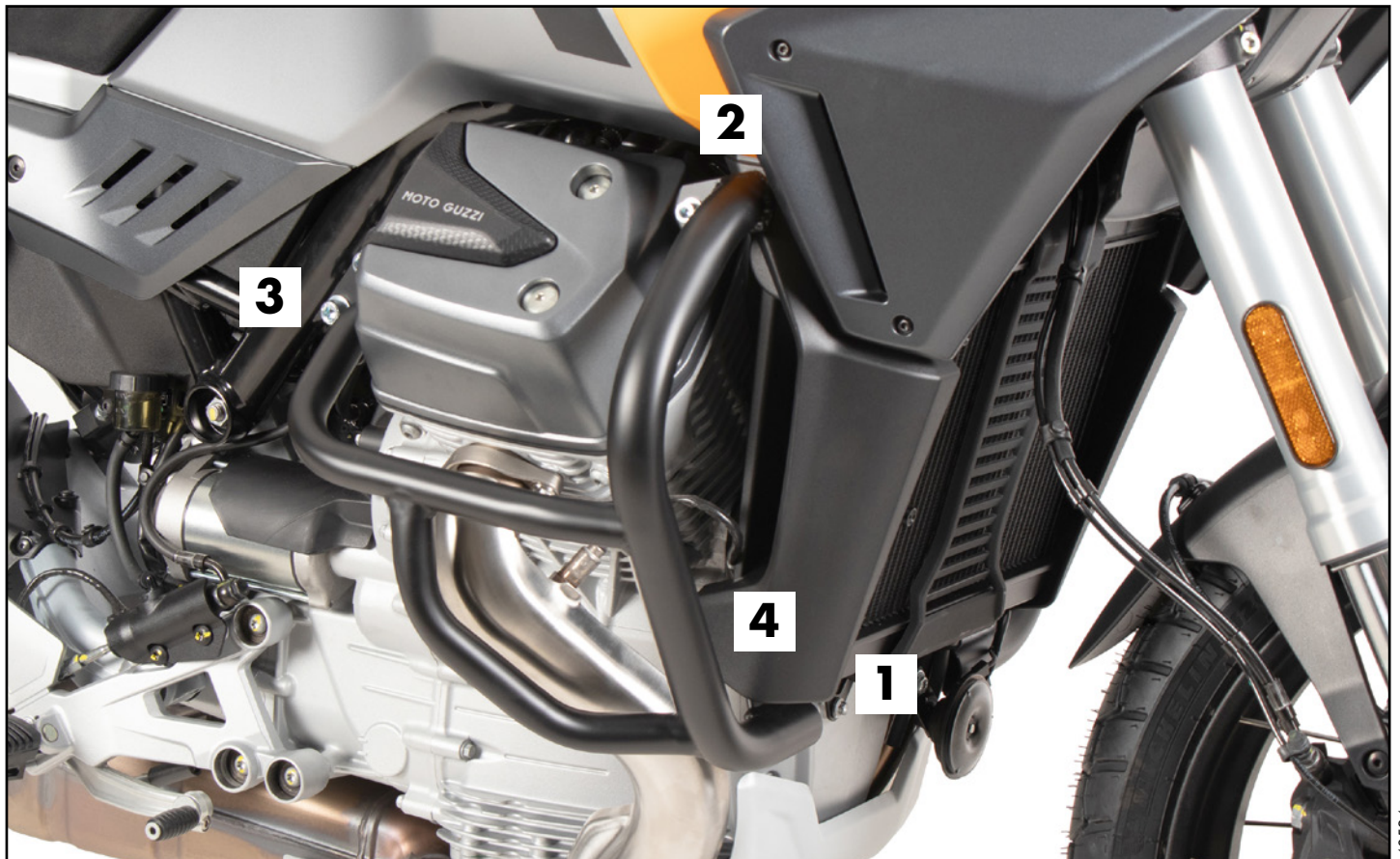

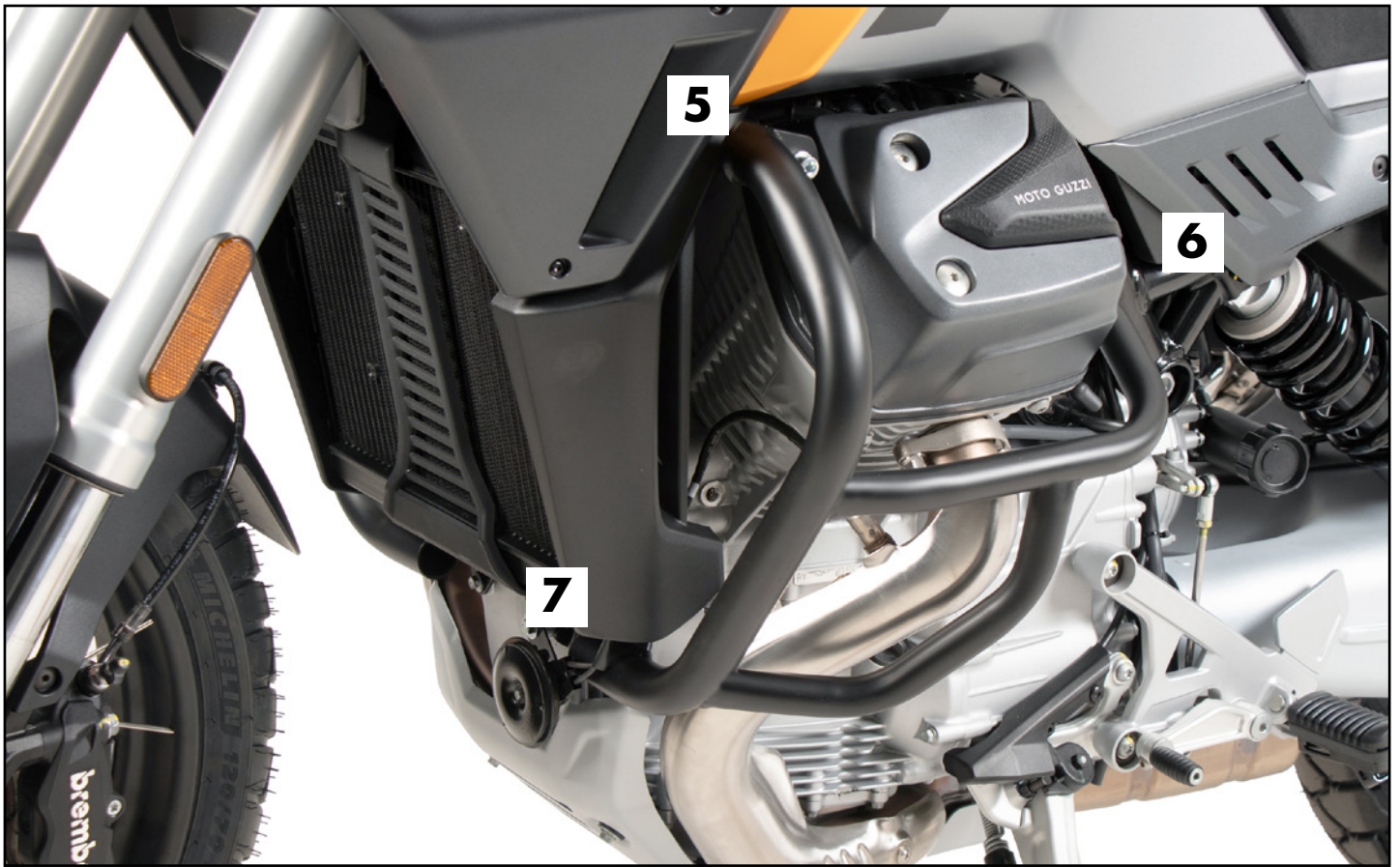

Wichtig / Important:

Beachten Sie die in Ihrem Land geltenden Zulassungsbestimmungen.
Für den Bereich der BRD gilt: Ein Eintrag in die Fahrzeugpapiere ist nicht erforderlich.

Wir empfehlen, die Montage in einer Fachwerkstatt durchführen zu lassen. Bei der Montage, alle zugänglichen Schrauben vorerst nur locker andrehen, sodass eine spannungsfreie Montage gewährleistet wird. Beim Anziehen der Schrauben, Anzugsmomente beachten.

We recommend having the installation carried out in a professional workshop. During installation, tighten all accessible screws loosely at first to ensure tension-free installation. When tightening the screws, observe the tightening torques.

**Eine Seite nach der anderen montieren. Ansonsten besteht die Gefahr, dass sich der Motor absenkt.
Mount one side after the other. Otherwise, there is the risk that the engine block change position.**

Vorbereitende Maßnahmen / Preparatory actions

Für eine bessere Zugänglichkeit die beiden Schrauben der unteren Kühlerbefestigung entfernen.
Jeweils die beiden hinteren Schrauben sowie vorne die untere Schraube der Rahmenbefestigung entfernen, diese entfallen.
Die Hupe demontieren. Der originale Blechhalter entfällt. Originalscheibe und -mutter werden wiederverwendet.

For better accessibility, remove the two screws of the lower radiator mounting.
Remove the two rear screws and the lower front screw of the frame mounting, these are no longer required.
Remove the horn. The original sheet metal holder is no longer required. Original washer and nut are reused.

Montageanleitung / Installation Instruction

Hupenhalter vorne:

Horn holder front:

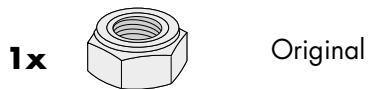
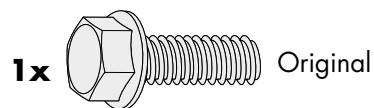

1

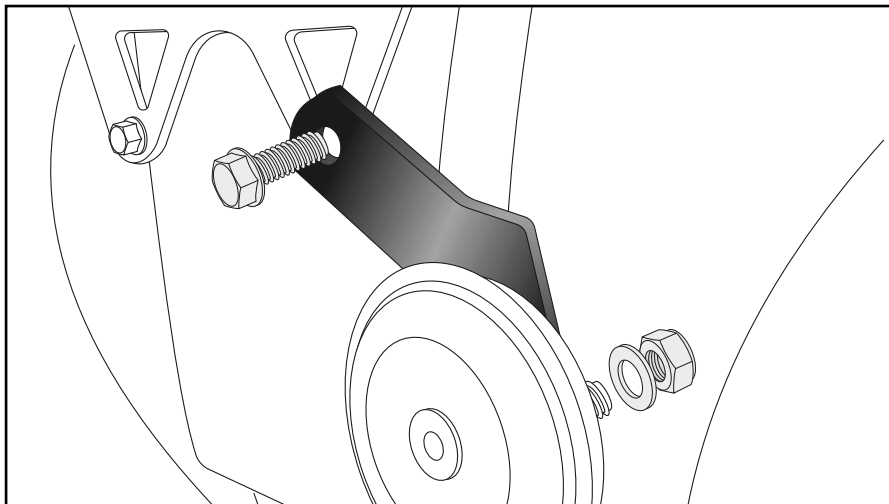

Motorschutzbügel rechts vorne oben:

Engine guard right front top:

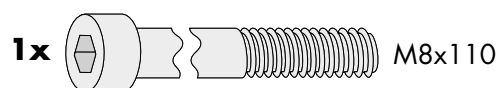

2

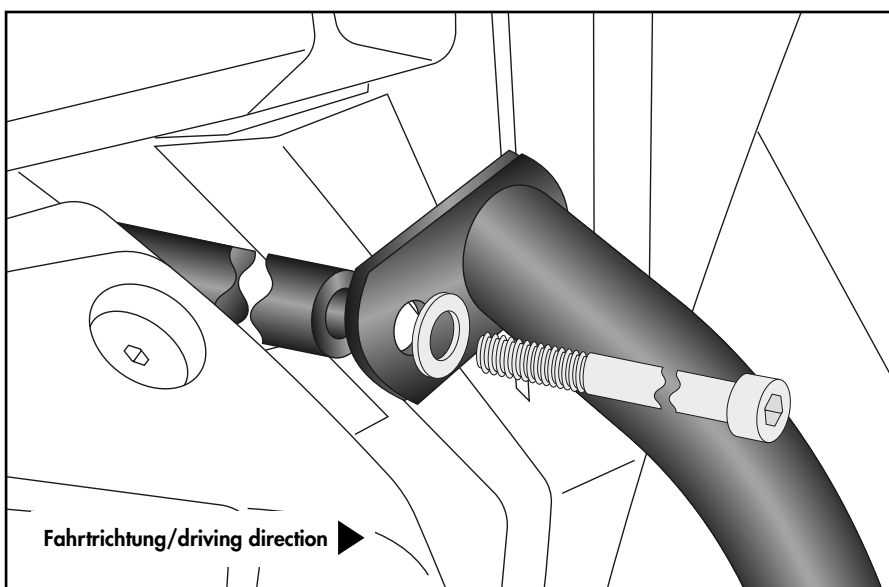

Motorschutzbügel rechts hinten:

Engine guard right rear:

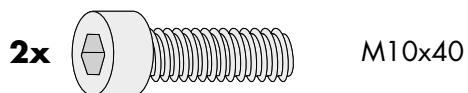

3

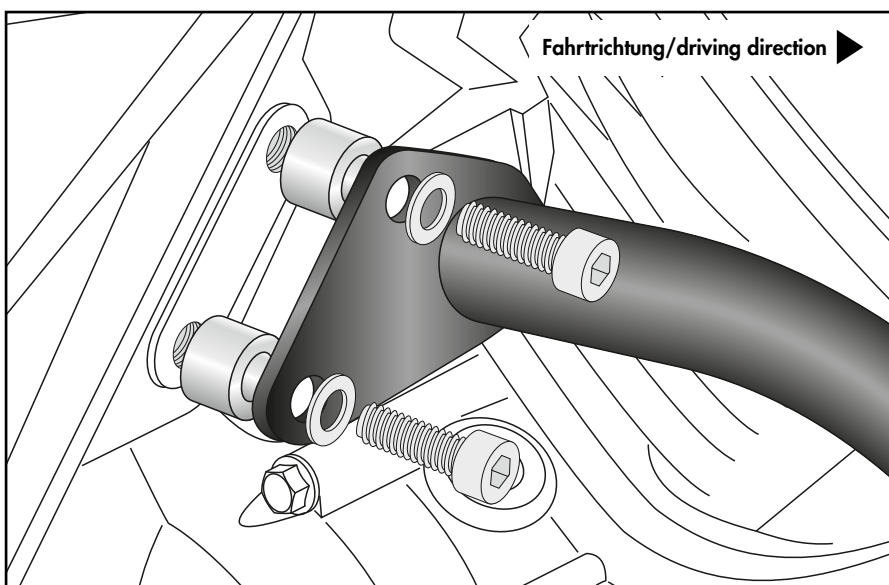

Montageanleitung / Installation Instruction

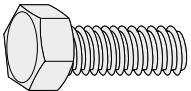
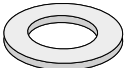
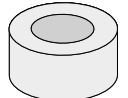

Motorschutzbügel rechts vorne unten:
Engine guard right front bottom:

- 1x**  M8x40
- 1x**  Ø8,4
- 1x**  Ø15xØ9x10

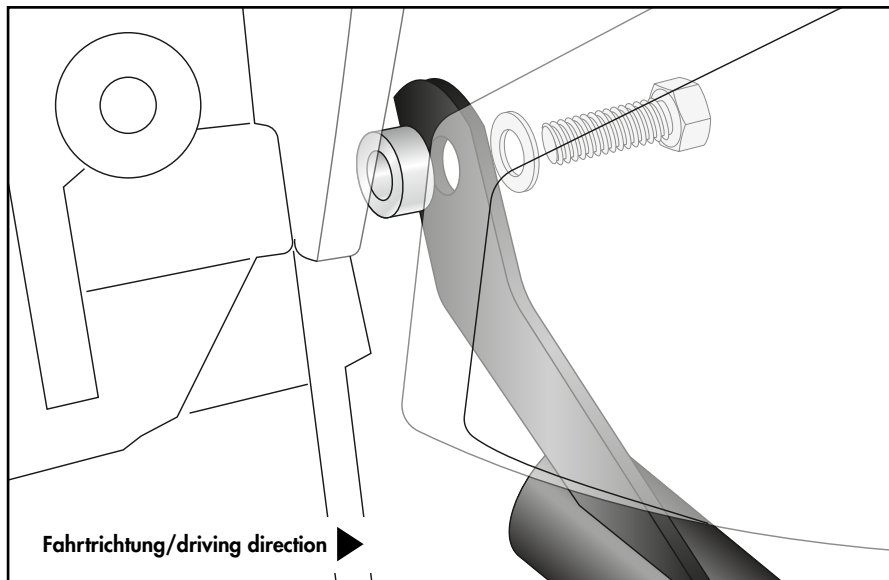
4



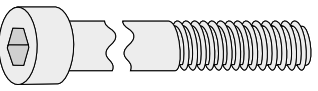

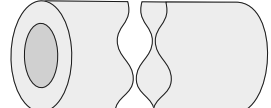
Motorschutzbügel links vorne oben:
Engine guard left front top:

- 1x**  M8x110
- 1x**  Ø8,4
- 1x**  Ø18xØ9x82

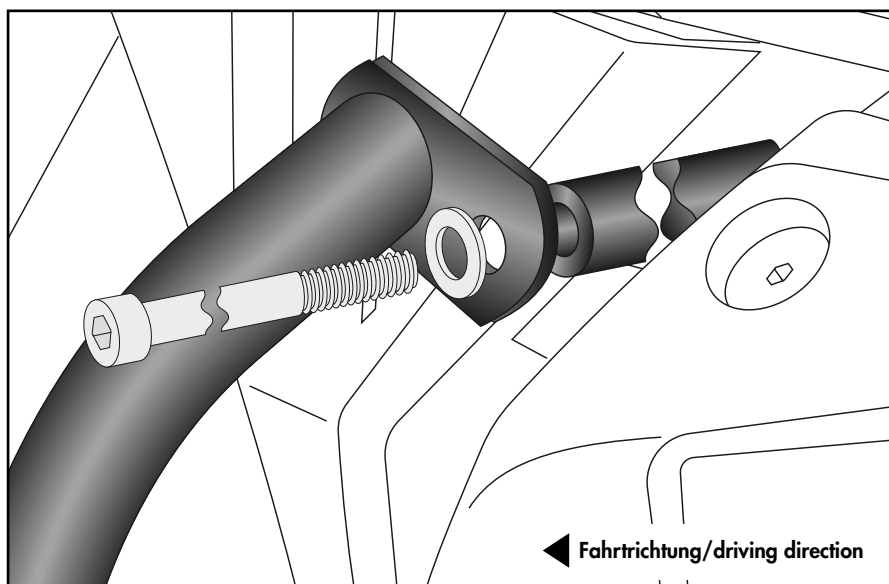
5

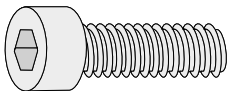

Motorschutzbügel links hinten:
Engine guard left rear:

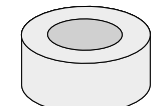
- 2x**  M10x40
- 2x**  Ø10,5
- 2x**  Ø20xØ11x15

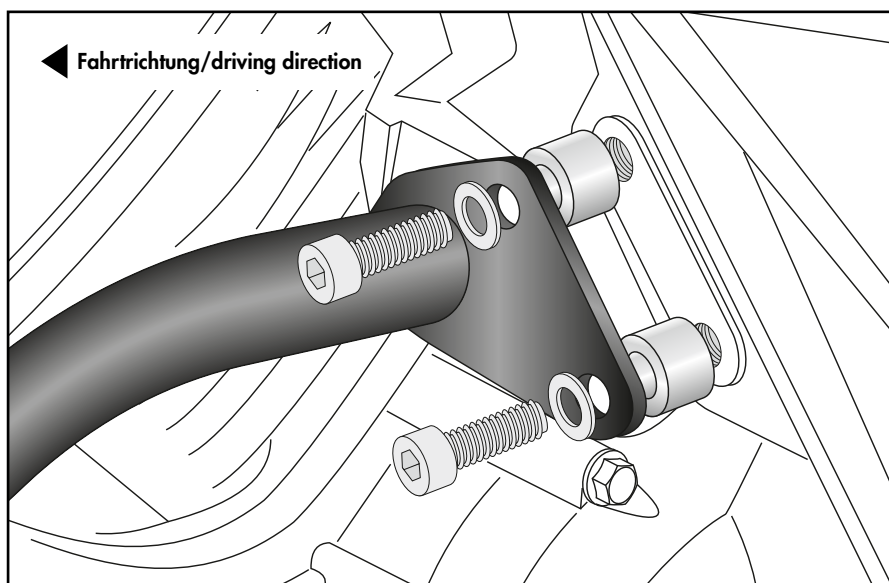

6



Montageanleitung / Installation Instruction

Motorschutzbügel links vorne unten:
Engine guard left front bottom:

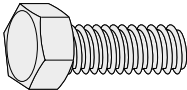
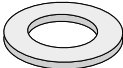
7

- 1x**  M8x40
- 1x**  Ø8,4
- 1x**  Ø15xØ9x10

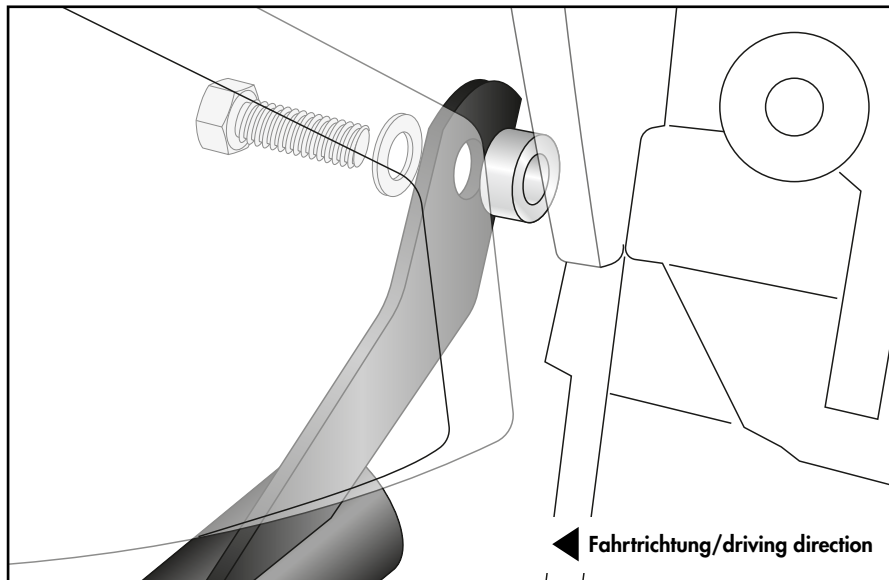

Achtung / Attention:

Nach der Montage alle Verschraubungen auf festen Sitz kontrollieren! Abgebaute Teile wieder montieren. Bitte beachten Sie unsere beigefügten Serviceinformationen.

Control all screw connections after the assembling for tightness! Reassemble the dismantled parts. Please notice our enclosed service information.

Weiteres Zubehör für dieses Modell auf www.hepco-becker.de / More accessories for this model see www.hepco-becker.de

HEPCO&BECKER GmbH | An der Steinmauer 6 | 66955 Pirmasens | Germany | Tel. +49 6331 1453100 | Fax: +49 6331 1453 120 | Mail: vertrieb@hepco-becker.de