

# TN8400 - KN8400

PARAMOTORE SPECIFICO - SPECIFIC ENGINE GUARD - PARE-CARTER SPECIFIQUE - SPEZIFISCHER STURZBÜGEL - DEFENSA DE MOTOR ESPECÍFICA - PARAMOTOR ESPECÍFICO

## HARLEY DAVIDSON Pan America 1250 (2021)

N°	Descrizione/Description	Caratteristiche/Features	Codice/Code	Quantità/Quantity
1	Paramotore - Engine Guard Pare-carter - Sturzbuegel Defensa De Moto - Paramotor	-	TN8400DXV TN8400SXV	2(Right; Left)
2	Vite - Screw Vis - Schraube Tornillo - Parafuso	TBEI M8x25	825TBEI	2
3	Vite - Screw Vis - Schraube Tornillo - Parafuso	TBEIFH M8x30	830TBEIFH	2
4	Vite - Screw Vis - Schraube Tornillo - Parafuso	TCEX M12x100	12100TCEX	2
5	Rondella spaccata - Split washer Scheibe - Rondelle fendue Arandela seccionada - Arruela Dentada	Foro Ø8mm	Z1060	2
6	Rondella - Washer Rondelle - Scheibe Arandela - Arruela	Foro Ø8mm	8RON	2
7	Distanziale - Spacer Entretoise - Distanzstueck Distanciador - Espaçador	Ø20x10 Foro 8,5mm	C20L10F8,5T	2
8	Distanziale - Spacer Entretoise - Distanzstueck Distanciador - Espaçador	-	V918	2
9	Distanziale - Spacer Entretoise - Distanzstueck Distanciador - Espaçador	Ø22x12 Foro 12,5mm	C22L12F12,5T	4
10	Componenti Originali - Original Parts Parties Originales - Original Bauteile Componentes Originales - Componentes Originais	-	-	-

# TN8400 - KN8400

PARAMOTORE SPECIFICO - SPECIFIC ENGINE GUARD - PARE-CARTER SPECIFIQUE - SPEZIFISCHER STURZBÜGEL - DEFENSA DE MOTOR ESPECÍFICA - PARAMOTOR ESPECÍFICO

## HARLEY DAVIDSON Pan America 1250 (2021)

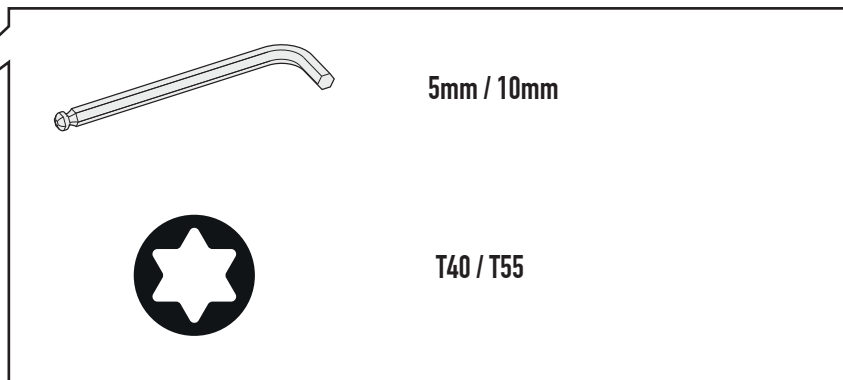
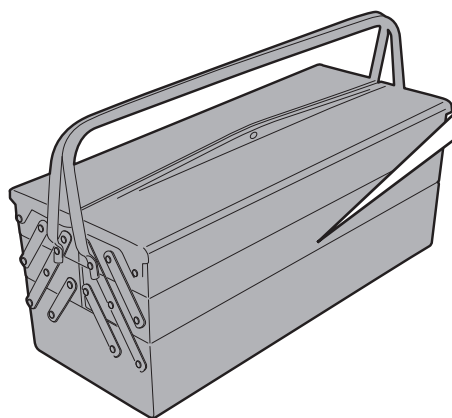
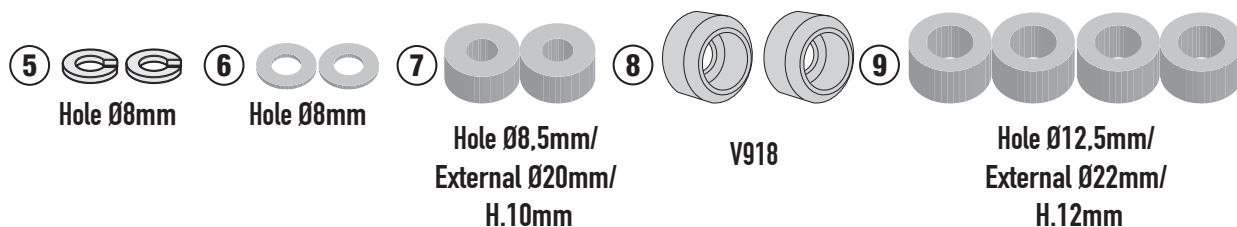
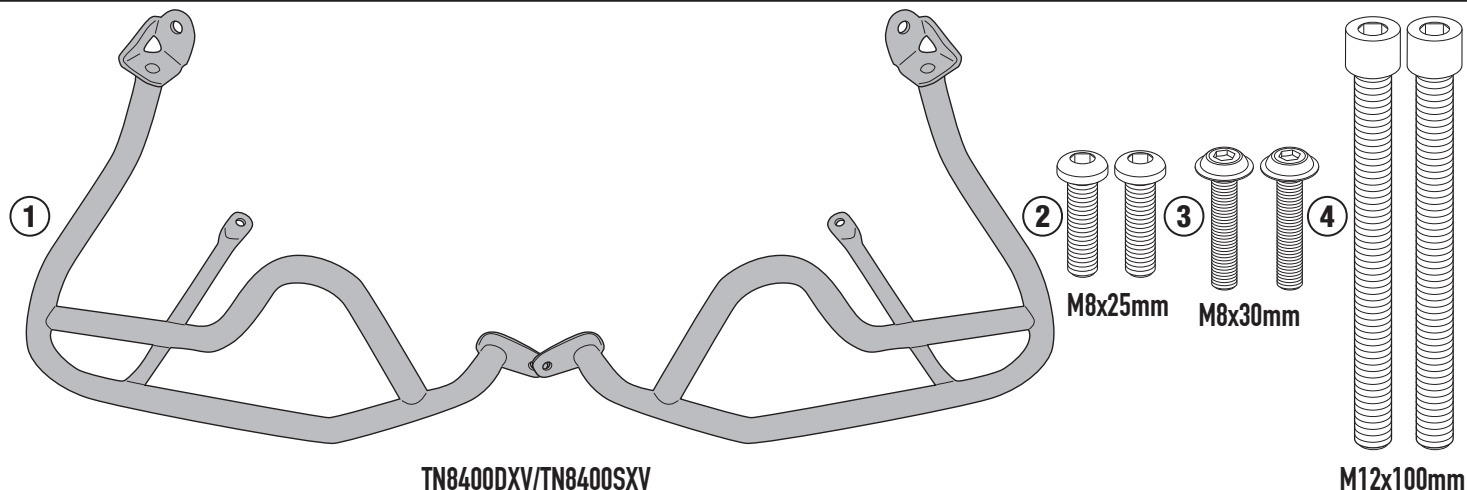

# TN8400 - KN8400

PARAMOTORE SPECIFICO - SPECIFIC ENGINE GUARD - PARE-CARTER SPECIFIQUE - SPEZIFISCHER STURZBUÈGEL - DEFENSA DE MOTOR ESPECÍFICA - PARAMOTOR ESPECÍFICO

## HARLEY DAVIDSON Pan America 1250 (2021)

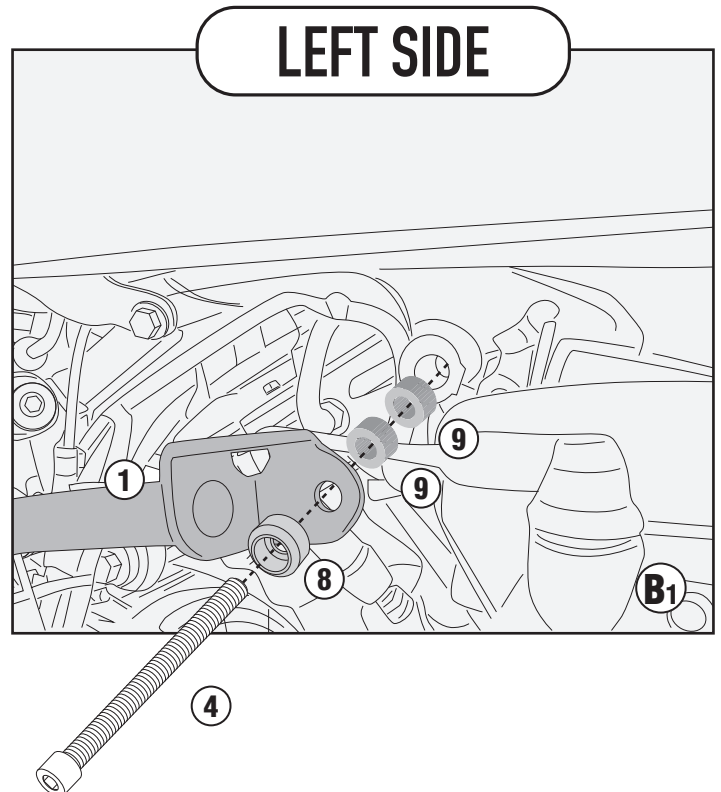
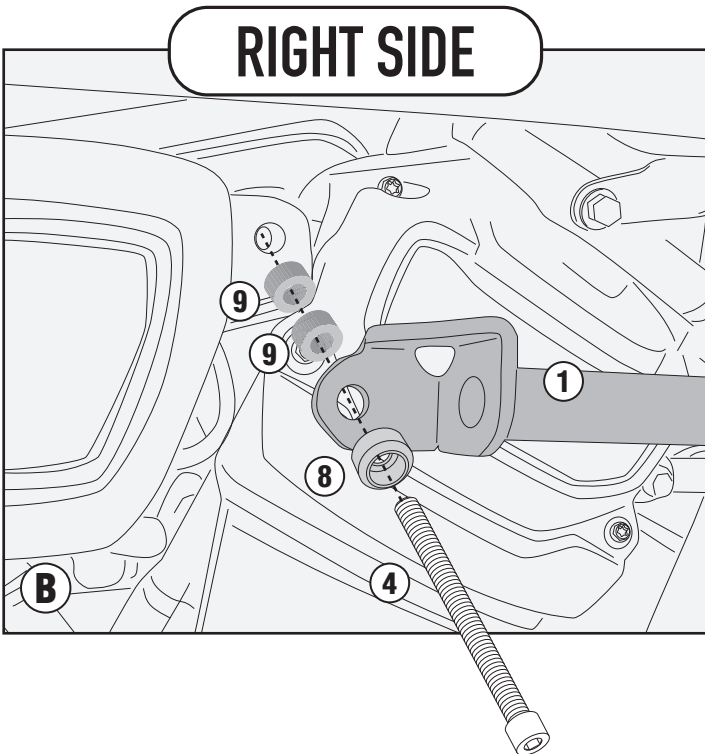
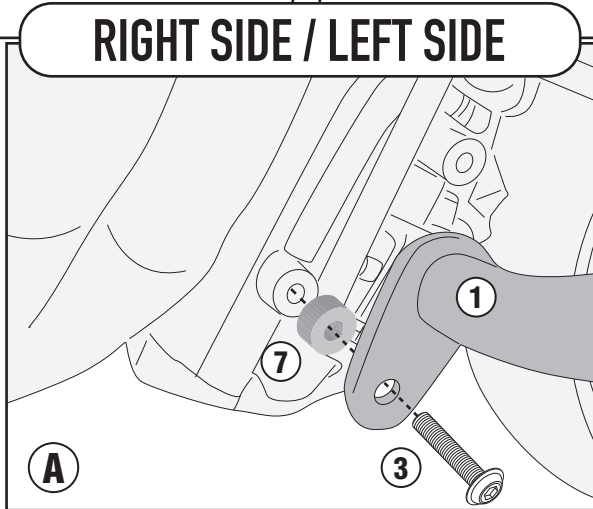
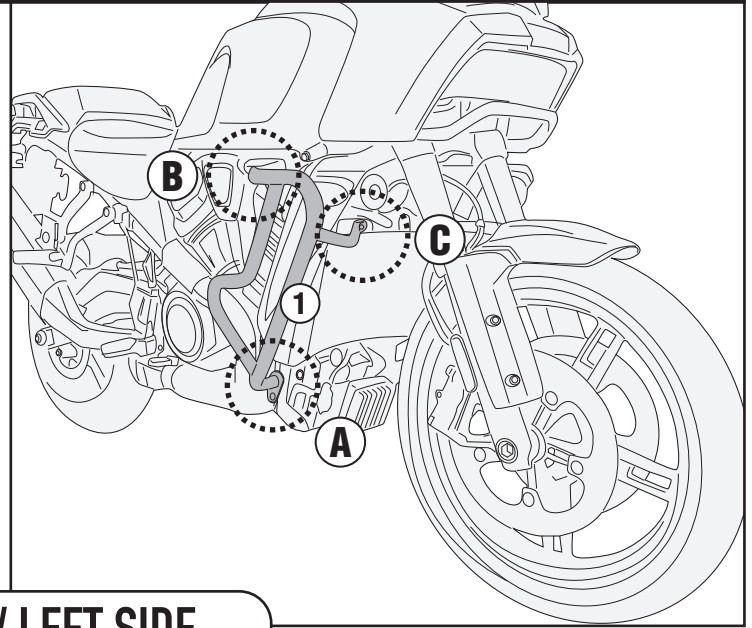
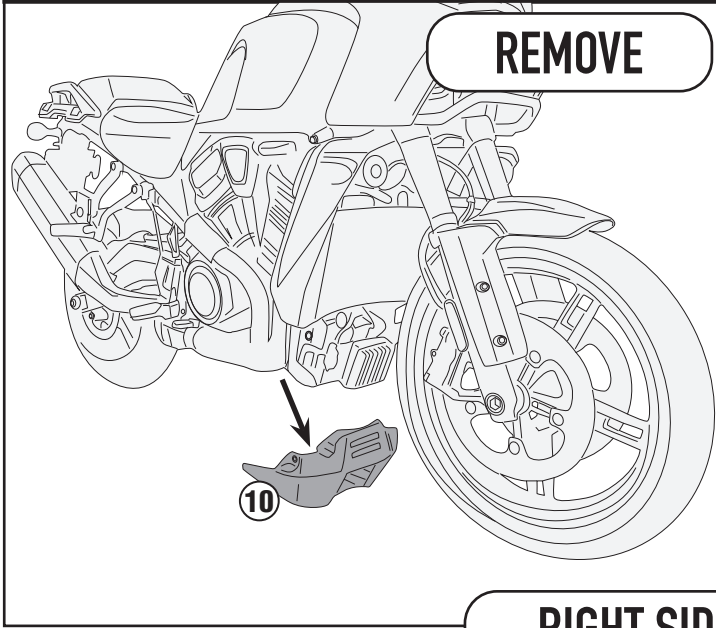

# TN8400 - KN8400

PARAMOTORE SPECIFICO - SPECIFIC ENGINE GUARD - PARE-CARTER SPECIFIQUE - SPEZIFISCHER STURZBÜGEL - DEFENSA DE MOTOR ESPECÍFICA - PARAMOTOR ESPECÍFICO

## HARLEY DAVIDSON Pan America 1250 (2021)

RIGHT SIDE / LEFT SIDE

