

EVOTECH®
P E R F O R M A N C E

www.evotech-performance.com

Ducati DesertX
Engine Guard



Kit Contents

- Ⓐ 1 x M6 x 10mm Black Button Head Bolts
- Ⓑ 4 x M4 Flange Nut

EVOTECH®
P E R F O R M A N C E

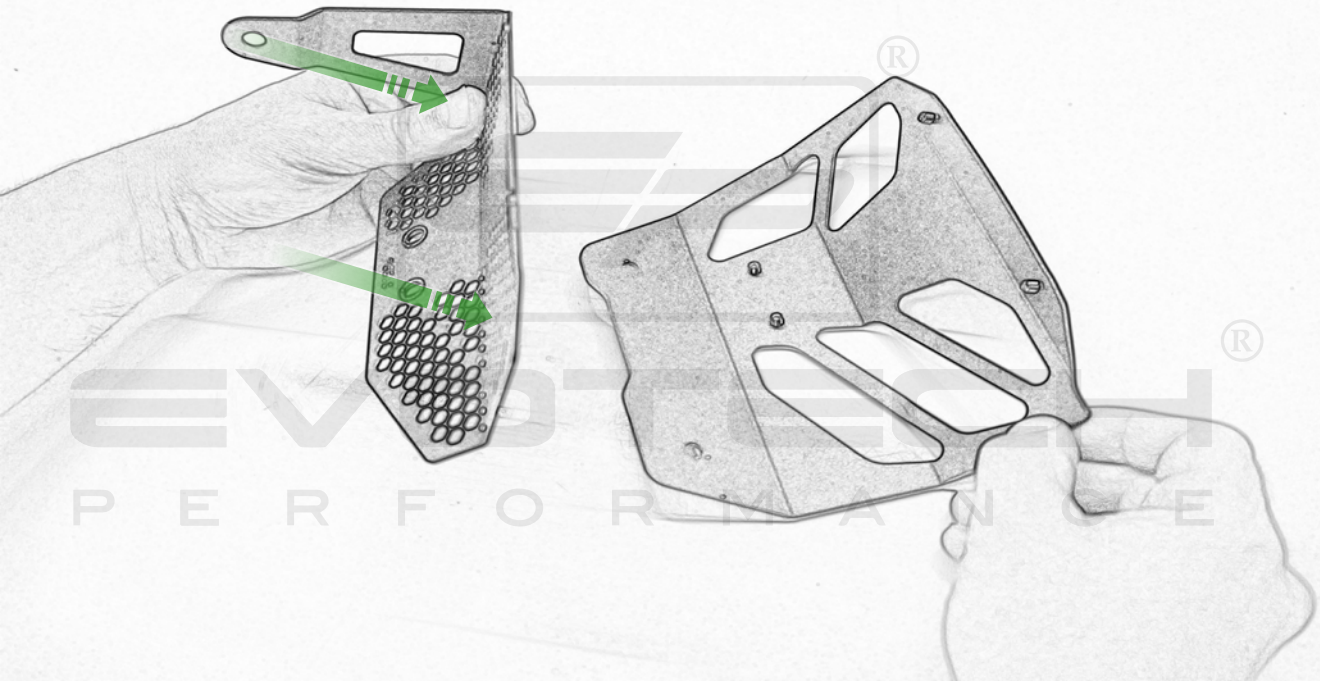

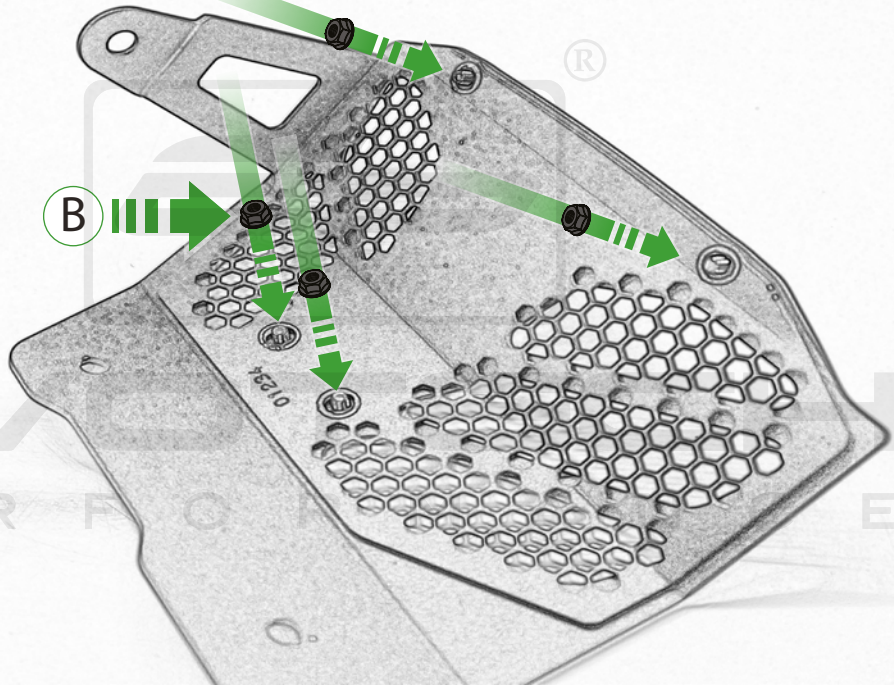

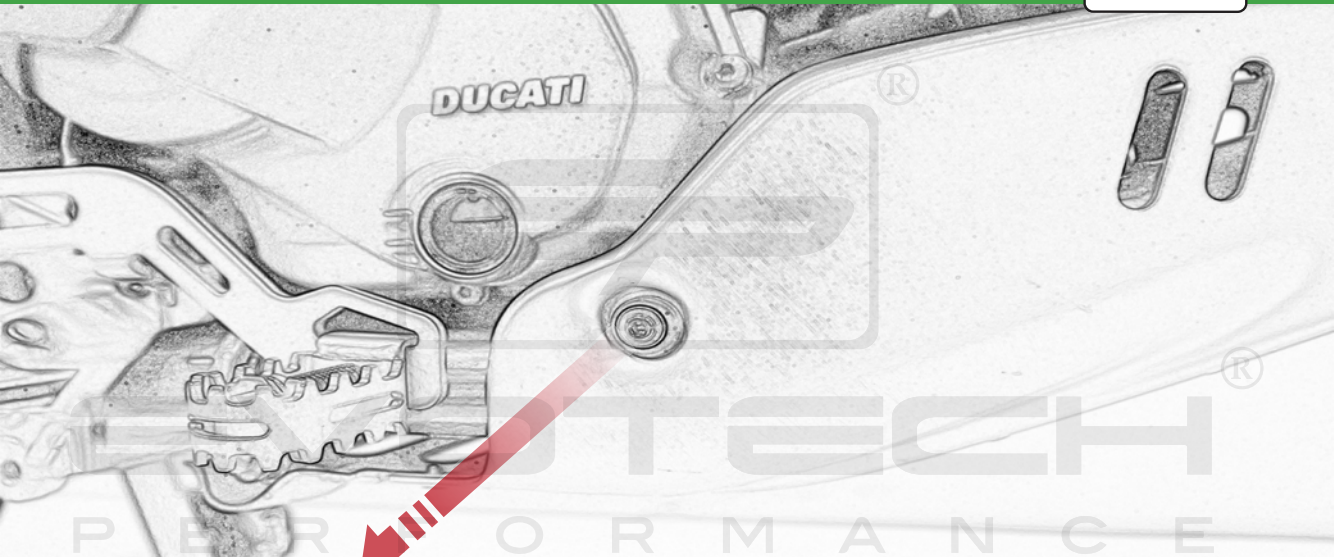

Repeat
Both Sides

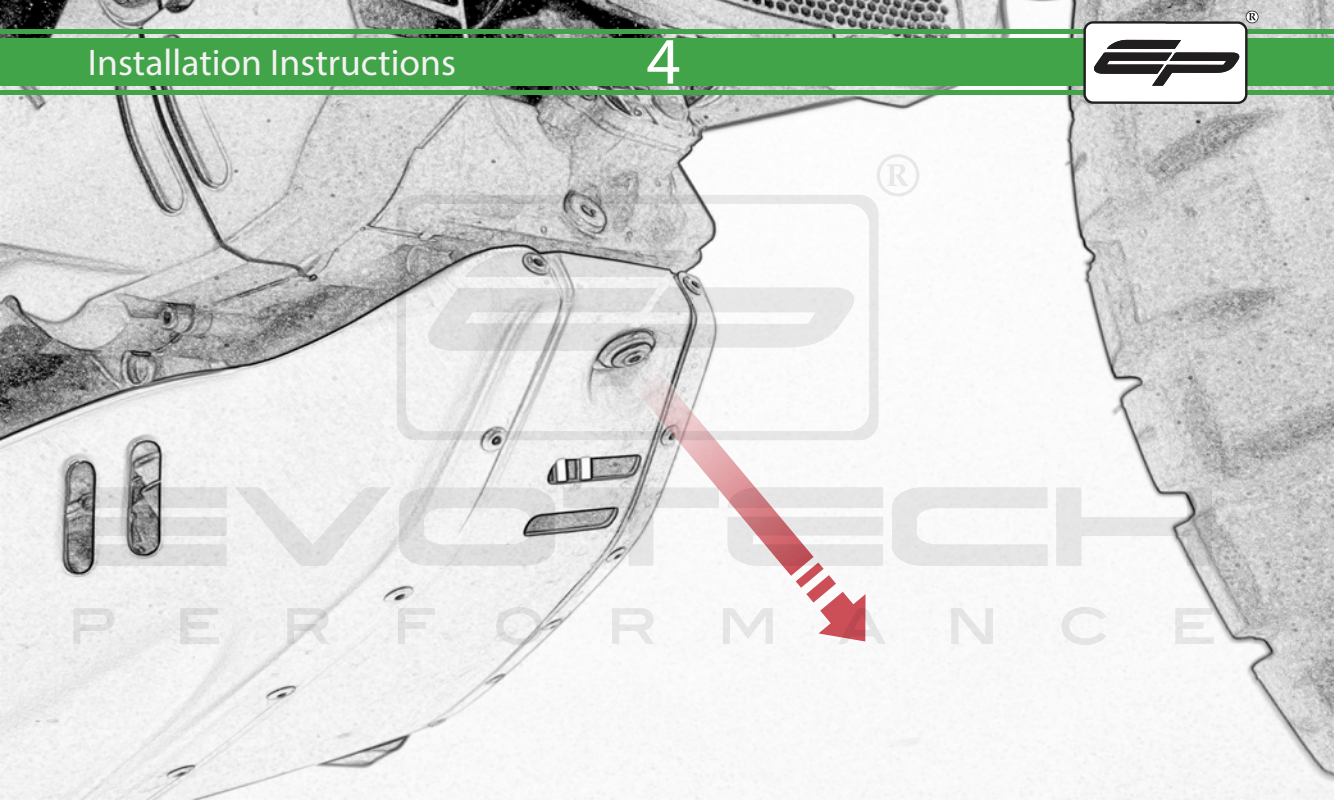

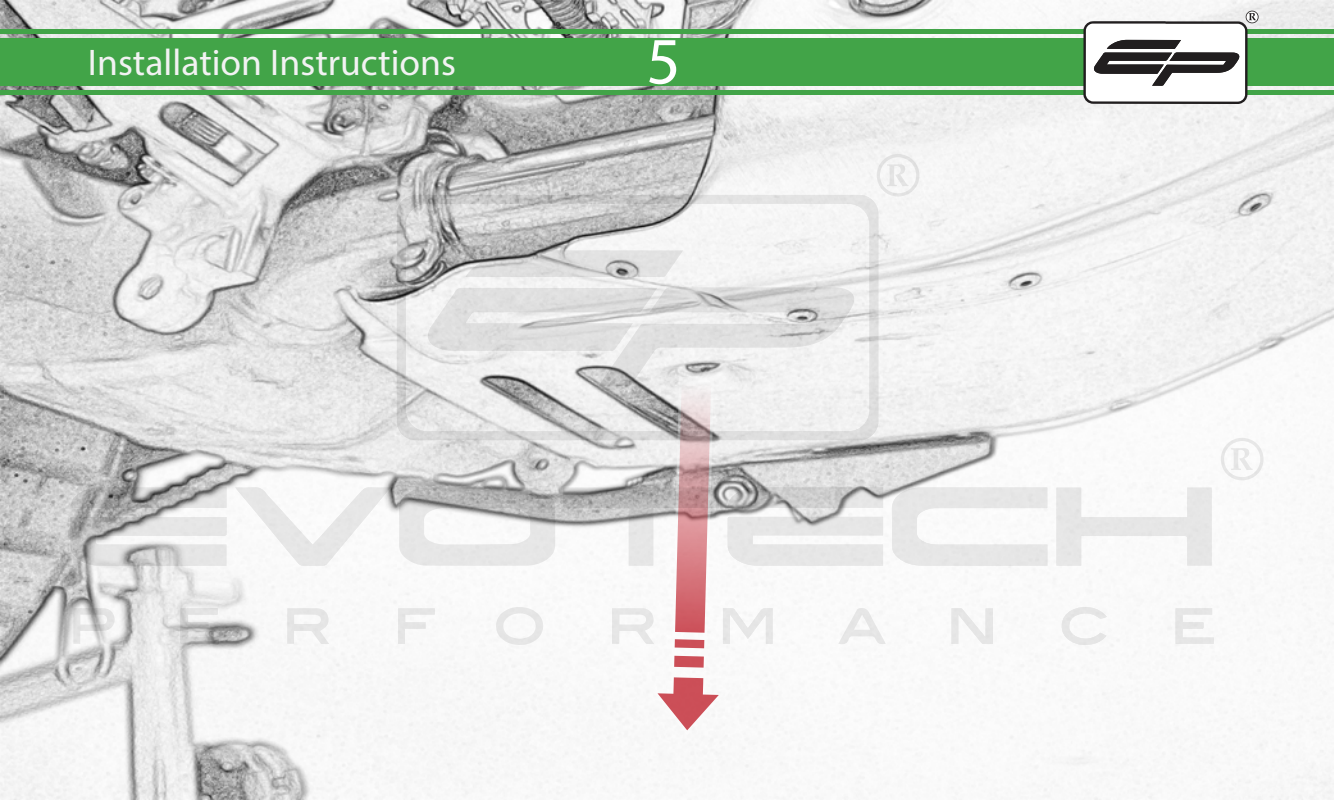

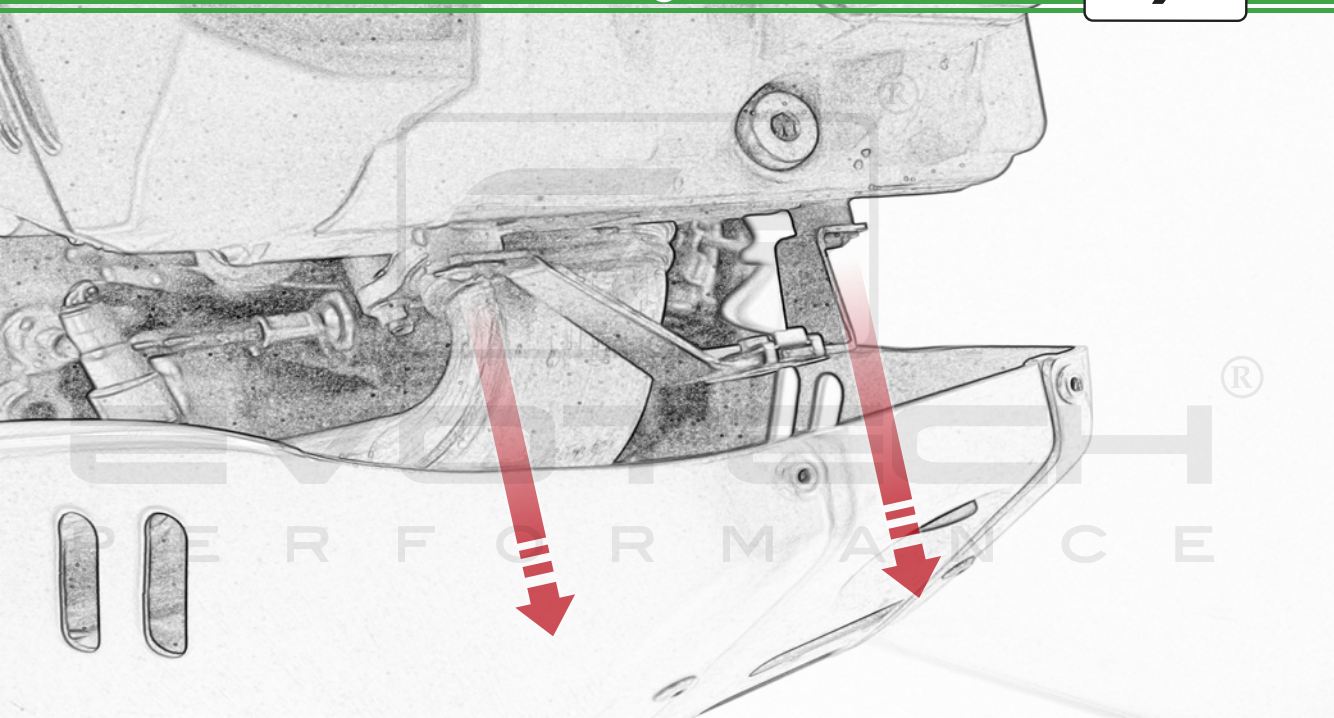

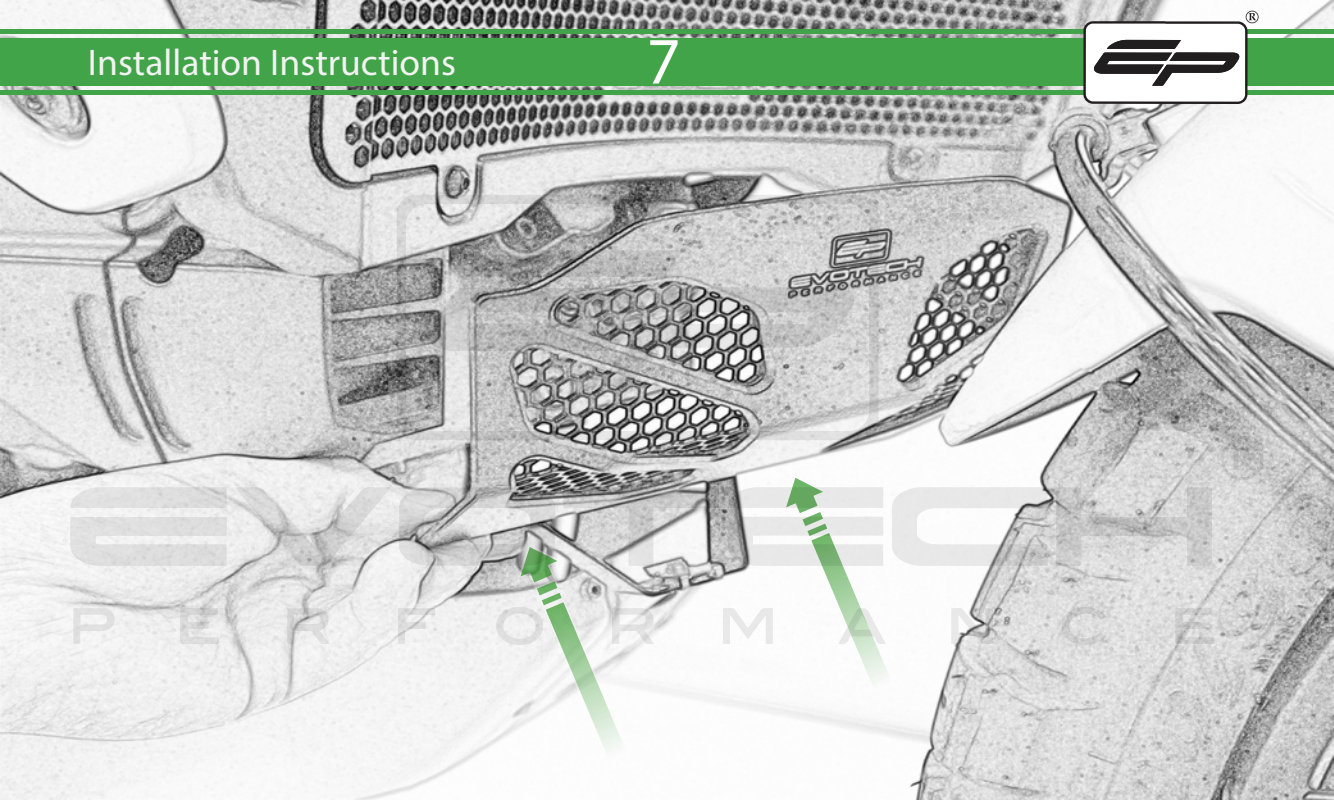

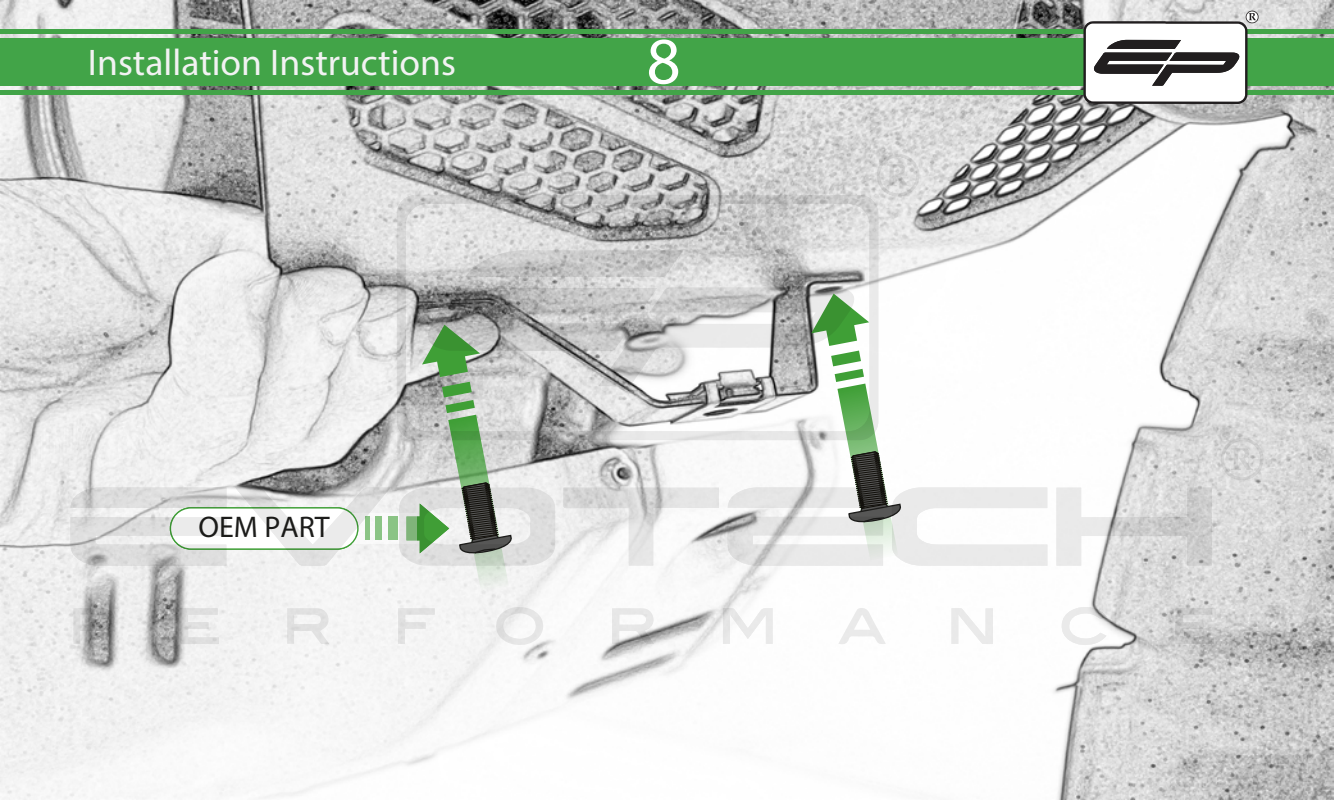

OEM PART

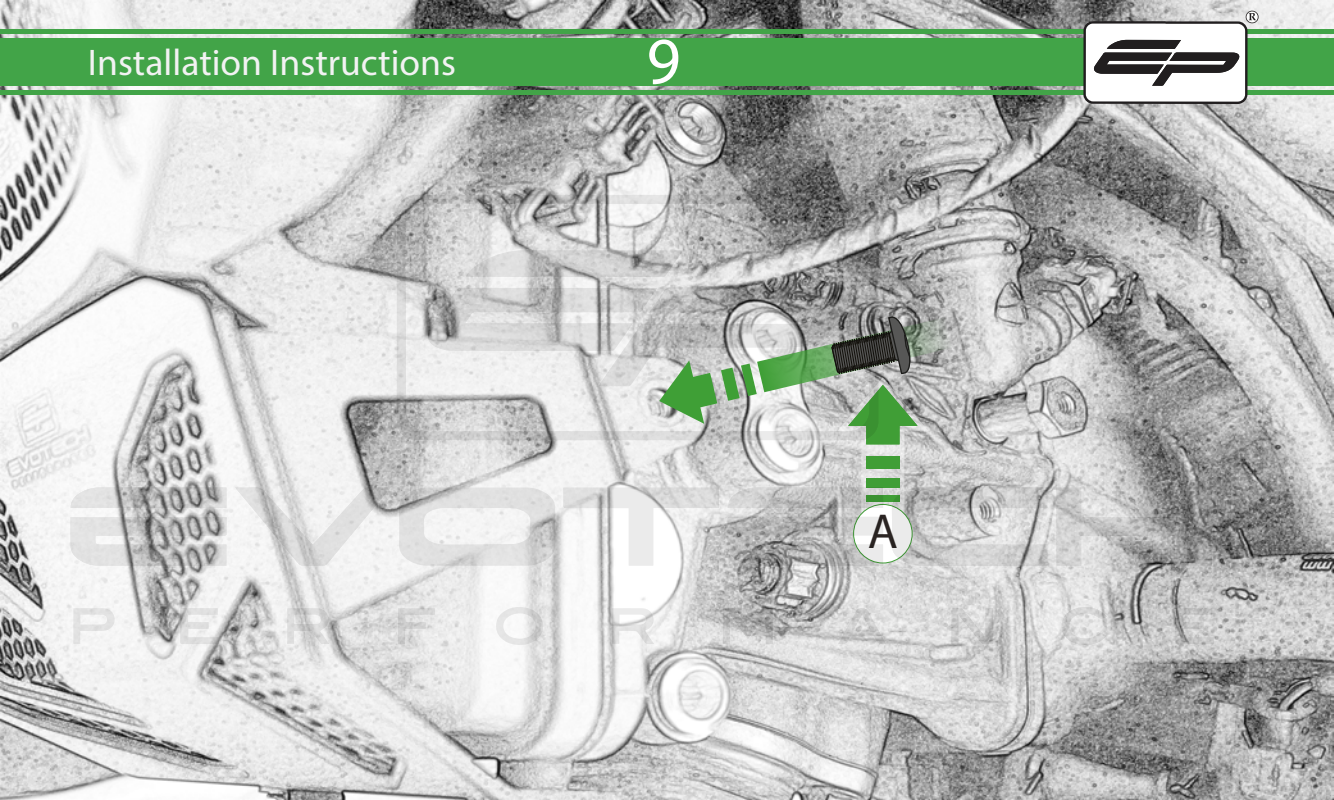



ESSENTIAL CHECKS

It is recommended that periodic inspections are made to ensure that dirt and debris have not become trapped between the guard and the radiator/oil cooler. Such dirt and debris would reduce the cooling efficiency of the radiator/oil cooler.

It is recommended that periodic inspections are made to ensure that all fixings are fully tightened.

EVOTECH[®]
P E R F O R M A N C E



EVOTECH®
P E R F O R M A N C E

www.evotech-performance.com