

DENALI™

HMT.11.10600

SOUNDBOMB HORN MOUNT

TRIUMPH

TIGER 800 (ALL MODELS)

2015-PRESENT

Thank you for choosing DENALI

We know you would rather be riding your bike than wrenching on it, so we go the extra mile to make sure our instructions are clear and as easy to understand as possible. If you have any questions, comments, or suggestions don't hesitate to give our gear experts a call at 855.255.5550 or visit DenaliElectronics.com/instructions.

Please Read Before Installing

DENALI products should always be installed by a qualified motorcycle technician. If you are unsure of your ability to properly install a product, please have the product installed by your local motorcycle dealer. DENALI takes no responsibility for damages caused by improper installation. **Caution:** When installing electronics is it extremely important to pay close attention to how wires are routed, especially when mounting products to the front fender, front forks, or fairing of your motorcycle. Always be sure to turn the handlebars fully left, fully right, and fully compress the suspension to ensure the wires will not bind and have enough slack for your motorcycle to operate properly.

Installation Tips

We strongly recommend using medium strength liquid thread locker on all screws, nuts, and bolts. It is also important to ensure that all hardware is tightened to the proper torque specifications as listed in your owner's manual. For included accessory hardware please refer to the default torque specifications provided below. Inspect all hardware after the first 30 miles to ensure proper torque specifications are maintained.

Bolt Size	in-lbs	ft-lbs	Nm
M3	10.0 in-lbs	-	1.0 Nm
M4	23.0 in-lbs	-	2.5 Nm
M5	44.5 in-lbs	3.5 ft-lbs	5.0 Nm
M6	78.0 in-lbs	6.5 ft-lbs	9.0 Nm
M8	-	13.5 ft-lbs	18.0 Nm
M10	-	30.0 ft-lbs	41.0 Nm
M12	-	52.0 ft-lbs	71.0 Nm

Hardware Sizing Guide

Not sure what size bolt you have? Use this ruler to measure screws, bolts, spacers, etc. Remember, the length of a screw or bolt is measured from the start of the "mounting surface" to the end of the screw, so only include the screw head when measuring countersunk screws.

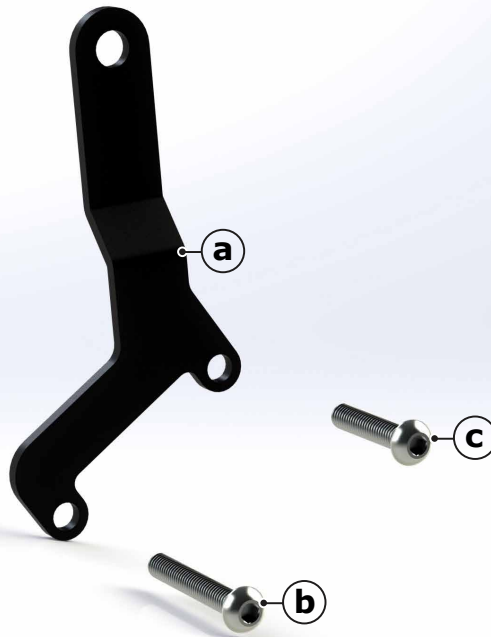
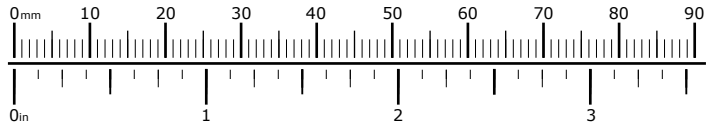

Kit Contents

- (a) Bracket.....Qty 1
- (b) M6x30 ISO 7380.....Qty 1
- (c) M6x45 ISO 7380.....Qty 1

Tools Required

- 4mm Allen Key
- 13mm Wrench
- 8mm Wrench

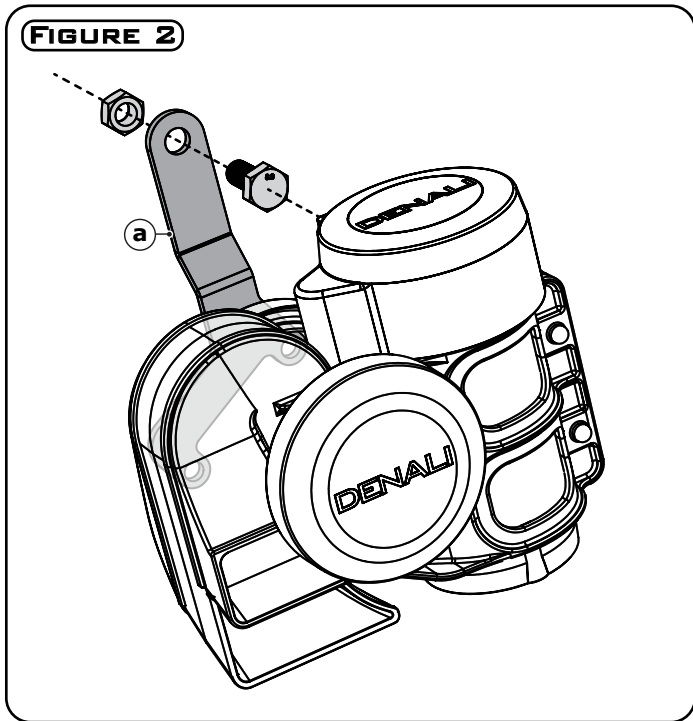

Mounting The Horn

Step One: Use the hardware included with the SoundBomb horn to attach the horn to the bracket (a) as illustrated above.

Note: Insert the mounting screws (b & c) into the bracket (a) before attaching the horn.

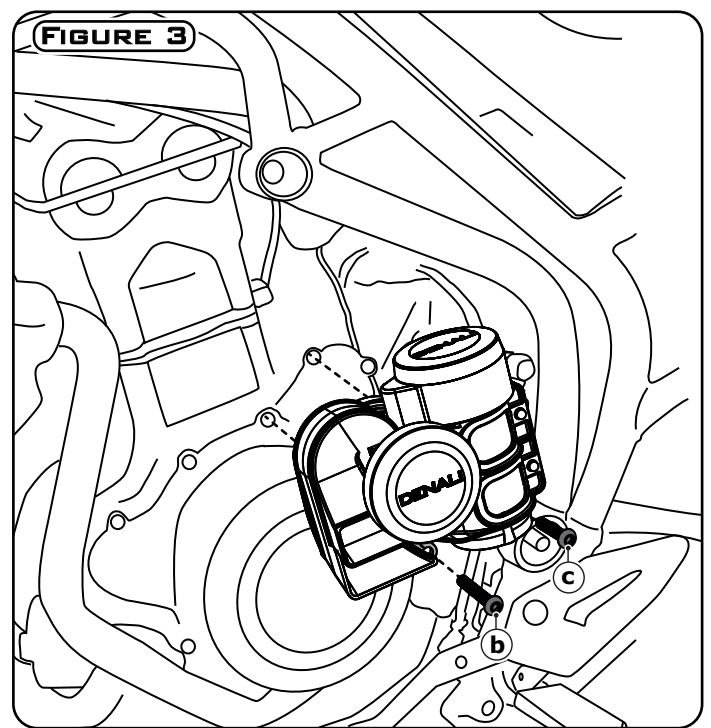

Installing The Bracket

Step Two: Remove the two OEM bolts from the engine case on the left hand side of the motorcycle.

Step Three: Use the M6 screws (b & c) to attached the horn and bracket to the motorcycle. The longer screw (b) goes in the hole closer to the front of the motorcycle.