

PROBEAM®

BY CUSTOM DYNAMICS®

Custom Dynamics® ProBEAM® Fillerz® LED Inserts Installation Instructions

We thank you for purchasing the Custom Dynamics® ProBEAM® Fillerz® LED Inserts! Our LEDs offer maintenance free service and higher visibility. Our ProBEAM® product line utilizes the latest technology and automotive grade components to ensure the highest level of reliable service. Custom Dynamics® offers one of the best warranty programs and customer support in the industry. If you have any questions during the installation of this product please call us at 1(800) 382-1388.

Part Number: PB-FILL-R-B PB-FILL-S-B
PB-FILL-R-C PB-FILL-S-C
US Patent D814673, D824553 & D846,166
China Patent ZL201730501975.7

Package Contents:

- ProBEAM® Fillerz® LED Inserts (1 pair)
- MPR-BCM-PLUG 6 Pin Adapter (1)
- 4" Cable Tie (8)

Fitment: 2014-2022 Electra Glide® Standard, Electra Glide® Ultra Classic®/Low, Ultra Limited®/Low, Road King®, Road Glide® Ultra, Road Glide Limited, Street Glide ST (FLHXST), Road Glide ST (FLTRXST) and 2019-2022 Electra Glide Standard (FLHT) and CVO™ Models **IF** Painted Filler Panels are Removed.

Will fit 2014-2022 Harley-Davidson® Street Glide, Street Glide Special, Road Glide, Road Glide Special, and Road King Special **when OEM rear fender fascia is removed**



1

⚠ ATTENTION ⚠

Please read all Information below before Installation

Note:

- Functions as **Run/Turn** on 2019-2022 Electra Glide® Standard (FLHT), 2014-2022 Road King® Standard, 2014-2015 Limited CVO™, & 2015 Road Glide Ultra CVO™. (ProBEAM® Eclipze® required for run, brake, turn function - sold separately, see page 3).
- The ProBEAM® Fillerz® are designed to be secured in place by the 3M™ backing tape on the Fillerz® Inserts, not by the alignment tabs (See Photo 3).
- This product is designed and intended for motorcycle auxiliary lighting use only. This product is **NOT** intended to replace any OEM lighting installed on the motorcycle and should not be used for that purpose. This product must be wired in such a manner that it does not interfere with any OEM lighting.

*****IMPORTANT*****

CAN Bus Models: This LED product is BCM compliant. However, you must run the 4 way hazard flashers for 3 minutes to allow the BCM to sync the new load after the new LED turn signals are installed.

Non-CAN Bus Models: A SMART Signal Stabilizer® or Load Equalizer is required to ensure proper turn signal function and have the proper flash speed.

Questions? Call us at: 1 (800) 382-1388 M-TH 8:30AM-5:30PM / FR 9:30AM-5:30PM EST

Installation Instructions - Page 2

Installation:

1. Remove the hard bags to allow access to the bag support brackets on the fender.
2. Remove the main seat on the bike and locate the 6 pin connector going to the rear fender. Unplug and install the MPR-BCM-PLUG adapter in line (See Photo 2).
3. Clean the surface area of the bag support bracket areas with the denatured alcohol and allow to dry.
4. Verify Left and Right Fillerz® panels before installing (See Photo 3).
5. Remove the red protective film of the 3M™ tape from the back of Fillerz®. Line up the bottom edge of Fillerz® with bottom edge of bag support bracket. Push Fillerz® into place until the alignment tabs click (See Photo 3). Apply pressure evenly over the Fillerz® to ensure the tape is applied evenly.
5. Route the wires from Fillerz® along the fender struts to the MPR-BCM-PLUG location. Secure the wires with the provided 4" cable ties.
6. Connect the left side Fillerz® to the MPR-BCM-PLUG 3 pin connector that has a purple wire. Connect the right side Fillerz® to the 3 pin connector with the brown wire.
7. Functions as **Run/Brake/Turn** on 2014- 2022 Electra Glide® Ultra Classic®/Low, Ultra Limited/Low, Road Glide® Ultra, 2020-2021 Road Glide Limited 2016 Road Glide Ultra CVO™, 2016-2021 Limited CVO™. Functions as **Run/Turn** on 2019-2022 Electra Glide® Standard (FLHT), 2014-2021 Road King® Standard, 2014-2015 Limited CVO™, & 2015 Road Glide Ultra CVO™. ([ProBEAM® Eclipze](#) required for run, brake, turn function - sold separately) (see page 3).
8. Test running, brake and turn signal functions.

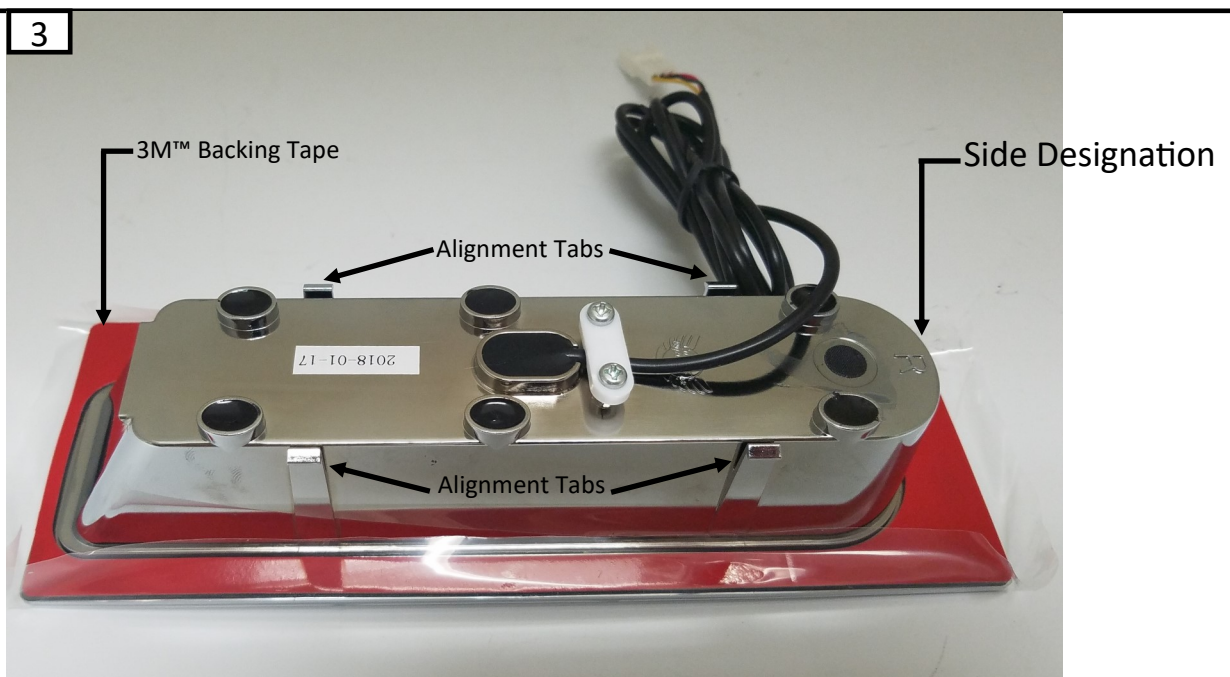
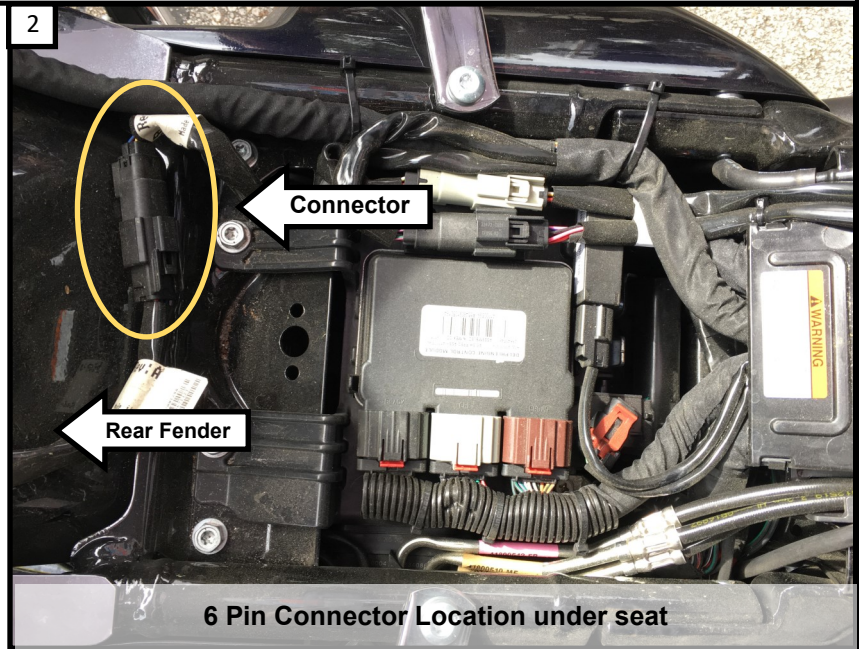

Questions? Call us at: 1 (800) 382-1388 M-TH 8:30AM-5:30PM / FR 9:30AM-5:30PM EST

Installation Instructions - Page 3

MPR-BCM-PLUG Diagram With Fillerz® as Run-Brake and Turn using PB-EPZ (sold separately)
 2019-2022 Electra Glide® Standard (FLHT), 2014-2022 Road King® Standard, 2014-2015 Limited CVO™, & 2015 Road Glide Ultra CVO™ Run-Brake-Turn *PB-EPZ required for run, brake, turn function (sold separately)

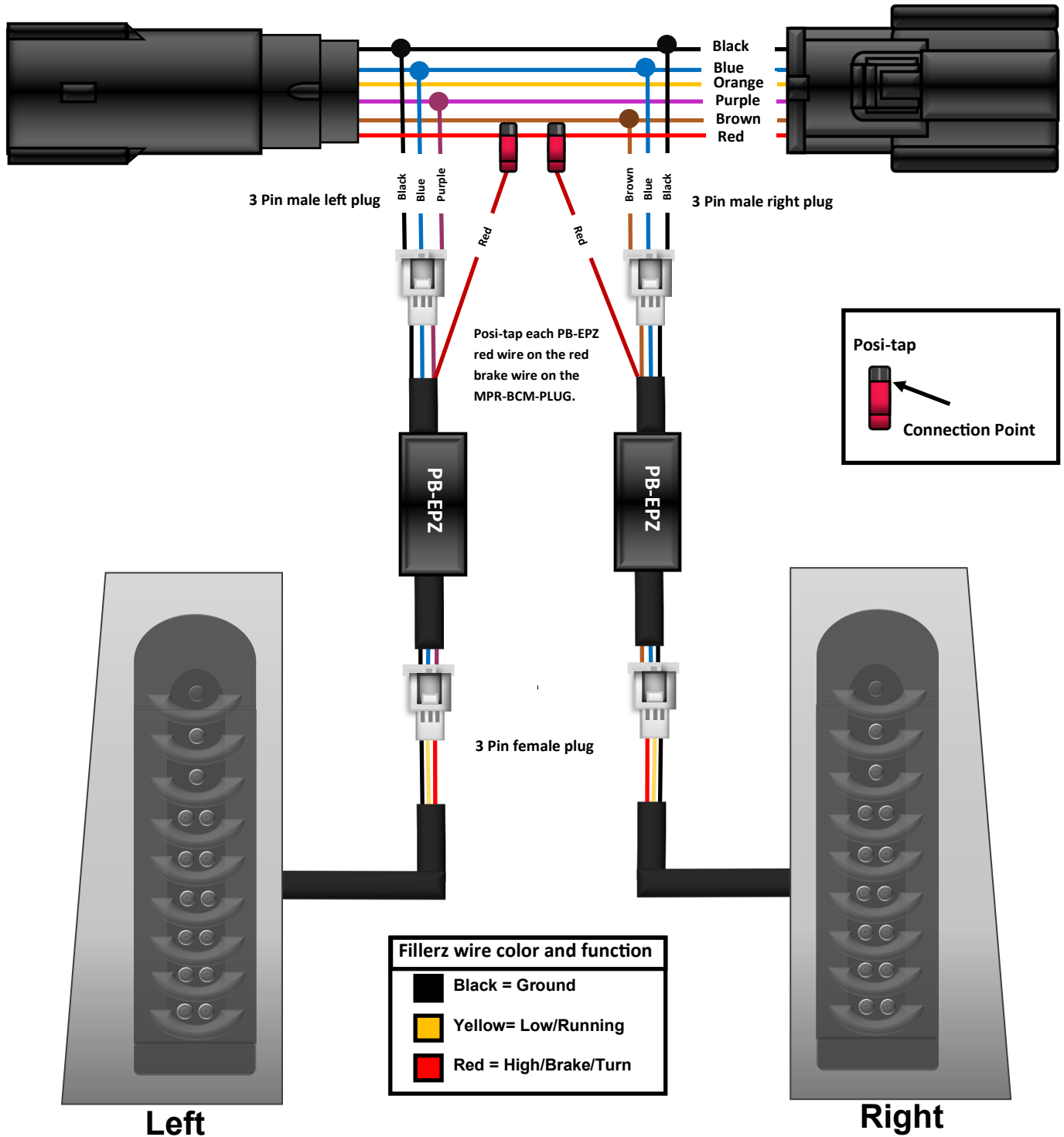

Notice: This product is designed and intended for motorcycle auxiliary lighting use only. This product is **NOT** intended to replace any OEM lighting installed on the motorcycle and should not be used for that purpose. This product must be wired in such a manner that it does not interfere with any OEM lighting.

Questions? Call us at: 1 (800) 382-1388 M-TH 8:30AM-5:30PM / FR 9:30AM-5:30PM EST

Installation Instructions - Page 4

Road King, Electra Glide Standard

Run-Turn (Original Configuration) MPR-BCM-PLUG

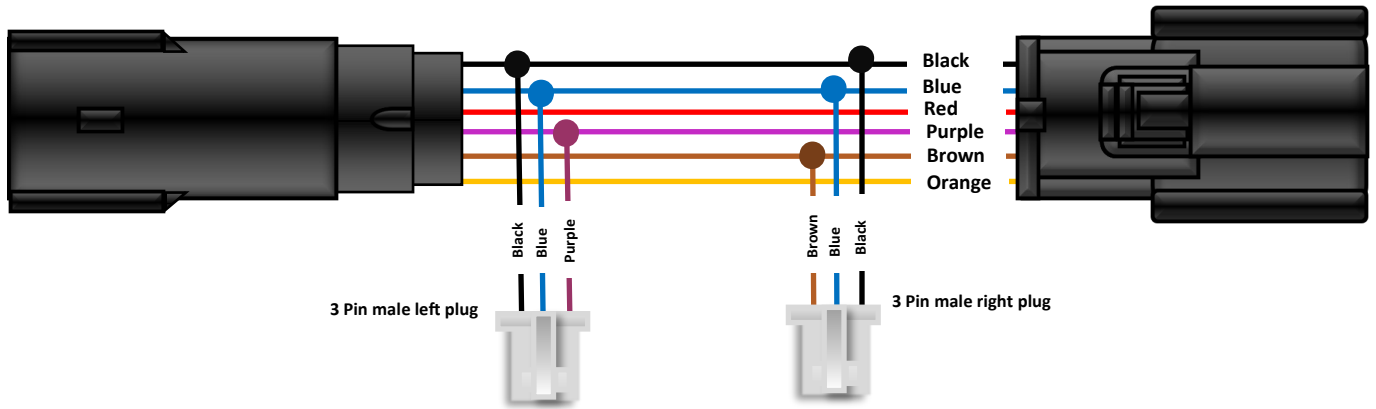

Run-Brake Modification MPR-BCM-PLUG

*Purple and Brown Wires going from the 3 Pin Connector to the Y Harness must be cut and moved to the red wire of the Y harness.

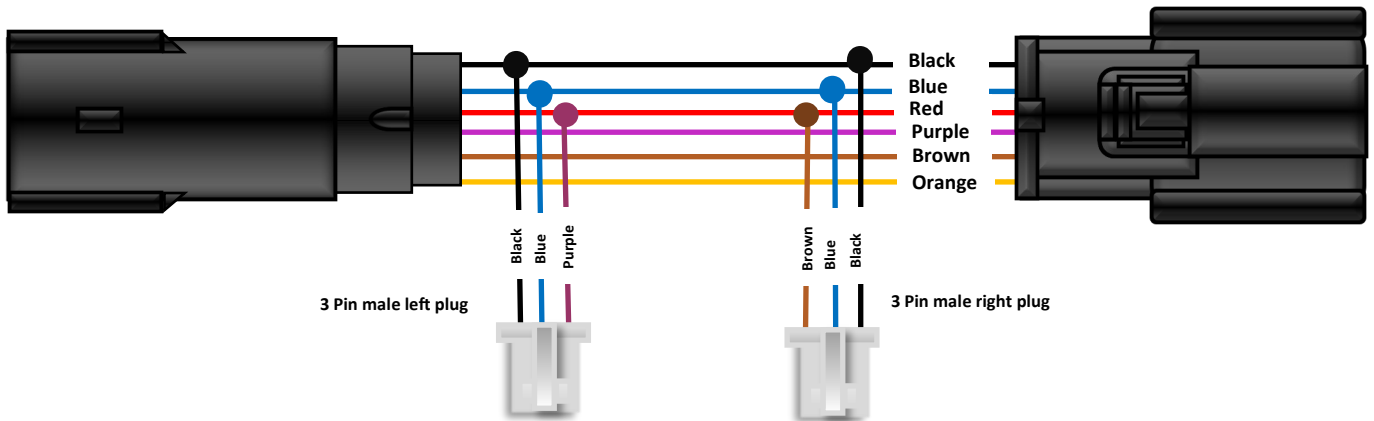

MPR-BCM-PLUG wire color and function

- Black- Ground
- Blue- Running
- Red- Brake
- Purple- Left Turn/Brake
- Brown- Right Turn/Brake
- Orange- Auxiliary Power